

Ingals LSB

Long Span Barrier

Product Manual



Release 11/25

MASH TL3 COMPLIANT

MASH TL4 COMPLIANT

www.ingalcivil.com.au

Table of Contents

1.0	Introduction	3
2.0	Specifications	3
3.0	Point of Redirection	4
4.0	Components List	5
5.0	Recommended Tools	7
6.0	Crash Test Analysis	8
7.0	Locally Designed & Produced	10
8.0	Installation	11
9.0	Installation Sequence	13
10.0	Maintenance	15
11.0	Product Storage	15
12.0	Repair	16
13.0	Installation Checklist	18
14.0	Technical Drawings	19

1.0 Introduction

Introducing the Ingal LSB (Long Span Barrier), a barrier product which is light weight, easy to install and provides a maximum clear span of 16m.

With a transportation friendly design, the major panels of the system are fabricated from Australian rectangular hollow section steel beams with panels and components no greater than 8m in length or 480kg in mass.

Each panel of the system comprises of 3 layers of steel beams to achieve a large contact footprint with the vehicle in the case of impact. This design combines geometrical advantages with a minimal weight system.

Interchangeable middle panels are combined with universal side panels to configure variations in length. The modular design ensures ease of installation and allows for simple, cost effective repairs with light weight panels and components, allowing ease of transportation.

The Ingal LSB (Long Span Barrier) is a MASHTL4 compliant system which is available in length configurations of 16m, 14m, 12m, 10m and 8m, providing efficient solutions for customer applications.

The Ingal LSB does not meet all geometrical design aspects of AS5100:2017, however it has been successfully tested to MASH TL4, which is compliant with AS5100:2017 regular performance level.

2.0 Specifications

Ingal LSB beam width:	150mm
Ingal LSB installed system width at Anchor Post:	400mm
Ingal LSB post mass:	185kg
Ingal LSB Height above ground:	1150mm
Ingal LSB ground clearance:	380mm
Containment level:	<ul style="list-style-type: none">• MASH Test Level 3• MASH Test Level 4• AS5100:2017- Regular Performance Level

MASH TL3 COMPLIANT

MASH TL4 COMPLIANT

**AS5100:2017
- Regular Performance Level**

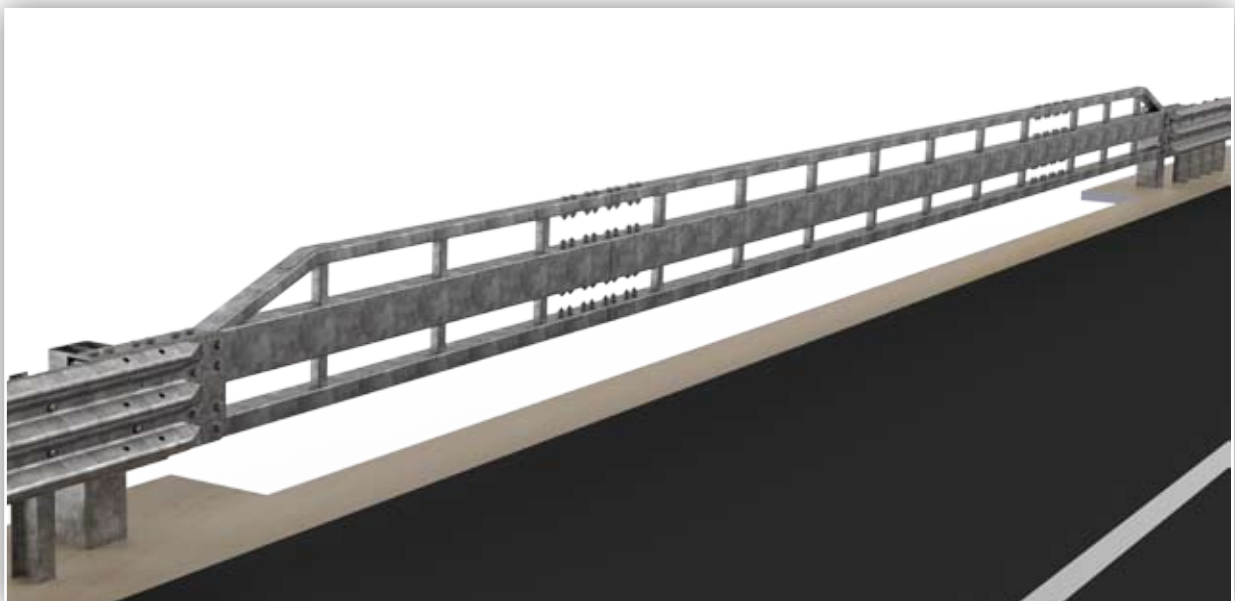

Table 1: Ingal LSB Lengths and Total Masses

Lengths	16m	14m	12m	10m	8m
Mass (including post)	1,905kg	1,786kg	1,667kg	1,547kg	1,292kg

Table 2: Ingal LSB Deflection

MASH TL3 Deflection	16m	14m	12m	10m	8m
	1.0m	0.92m	0.79m	0.69m	0.56m
MASH TL4 Deflection	16m				
	1.4m				

Note:

- 16m deflection values based upon Crash Testing
- 14m, 12m, 10m & 8m deflection values based on simulation testing conducted & validated in accordance with ASBAP SBTA 22-004



8m Length = 1,292kg mass



10m Length = 1,547kg mass



12m Length = 1,667kg mass



14m Length = 1,786kg mass



16m Length = 1,905kg mass

3.0 Point of Redirection

The Ingal LSB is designed to be fully embedded in a MASH compliant longitudinal barrier system terminated by a MASH compliant end terminal. The transition panels on either side of the LSB provide a smooth stiffness transition which ensures vehicle can be redirected at any point along the Ingal LSB as well as along the transition.



4.0 Components List

Before assembling the Ingal LSB System, carefully unpack and inspect all components for signs of damage. Check the received parts against the packing list supplied with the system to verify that all parts were received. If parts are damaged or missing from the shipment or unspecified parts were part of the shipment, do not attempt to assemble the system; contact Ingal Civil immediately.

All posts and rails are hot dip galvanized in accordance with AS/NZS 4680. It is important that stored galvanized work is stacked so that each item is well ventilated and can adequately drain rainwater from its surfaces. Poor storage can give rise to wet storage staining (white rust) which is caused by water (rain or condensation) in badly drained or ventilated conditions. This can occur very quickly, particularly in warm, humid conditions.

COMPONENT	PN	16m
Anchor Post Assembly	10010668	2
M16 x 450 Structural Bolt Nut Washer Set - Grade 8.8 to AS1252 K0 Class	10010511	12
Leading-Trailing Panel Assembly	10010669	2
Mid Beam Joiner	10010671	4
RHS - 250 x 150 x 5 - 245mm	10010648	2
M24 x 150 Structural Bolt - Grade 8.8 to AS1252 K0 Class	10010513	20
RHS - 150 x 100 x 4 - 245mm	10010647	2
M24 x 330 Threaded Rod - Grade 8.8 to AS1252 K0 Class	10010568	16
Lower Beam Joiner	10010672	4
M24 x 300 Structural Bolt Nut Washer Set - Grade 8.8 to AS1252 K0 Class	10010514	4
M24 x 170 Structural Bolt - Grade 8.8 to AS1252 K0 Class	10010567	8
M24 x 330 Structural Bolt Nut Washer Set - Grade 8.8 to AS1252 K0 Class	10010569	8
Upper Beam Joiner	10010673	2
M24 x 120 Structural Bolt Nut Washer Set - Grade 8.8 to AS1252 K0 Class	10010566	16
Concrete Footing Reo Bar	10010554	2
Nord Lock Washer M24 - NL24sp Grade 8.8	10010570	88
M24 Structural Nut - Grade 8.8 to AS1252 K0 Class	10002169	60
Ingal Long Span Barrier Connection Plate	10010684	2
M24 x 200 Structural Bolt Nut Washer Set - Grade 8.8 to AS1252	10002171	8
M24 x 50mm Bolt Nut Set - Grade 8.8	10009685	4
Ingal Long Span Barrier Installation Stand	10010685	4
Intermediate Panel Assembly - 8m (used in 16m system)	10010670	1
Intermediate Panel Assembly - 6m (used in 14m system)	10010674	
Intermediate Panel Assembly - 4m (used in 12m system)	10010675	
Intermediate Panel Assembly - 2m (used in 10m system)	10010676	

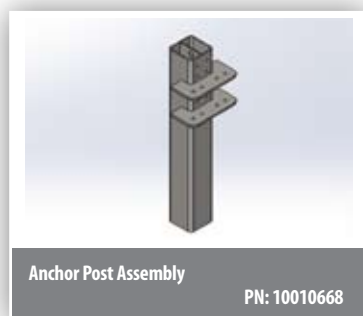

Ingal LSB Long Span Barrier

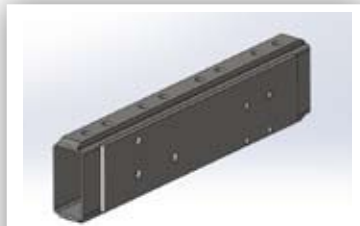

Mid Beam Joiner

PN: 10010671



RHS - 250 x 150 x 5 - 245mm

PN: 10010648



M24 x 150 Structural Bolt - Grade 8.8

PN: 10010513

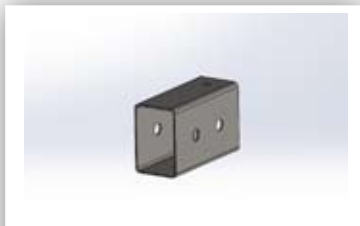

RHS - 150 x 100 x 4 - 245mm

PN: 10010647



M24 x 330 Threaded Rod

PN: 10010568



Lower Beam Joiner

PN: 10010672



M24 x 300 Structural Bolt Nut Washer Set - Grade 8.8

PN: 10010514



M24 x 170 Structural Bolt - Grade 8.8

PN: 10010567



M24 x 330 Structural Bolt Nut Washer Set - Grade 8.8

PN: 10010569



Upper Beam Joiner

PN: 10010673

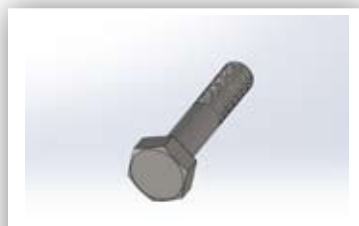

M24 x 120 Structural Bolt Nut Washer Set - Grade 8.8

PN: 10010566

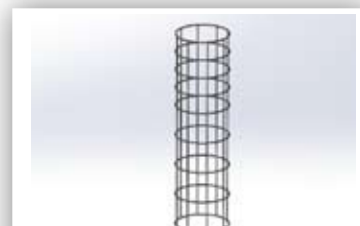

Concrete Footing Reo Bar

PN: 10010554

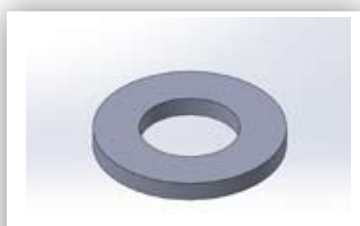

Nord Lock Washer M24 - NL24sp

PN: 10010570

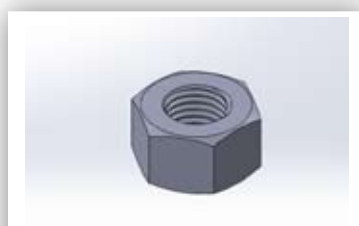

M24 Structural Nut Grade 8.8

PN: 10002169

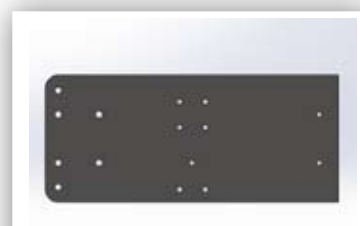

Ingal Long Span Barrier Connection Plate

PN: 10010684

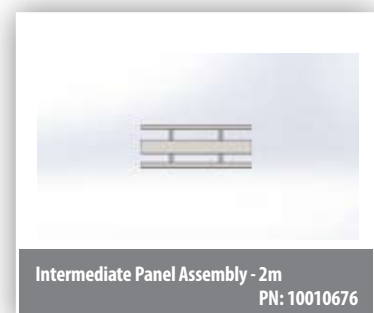
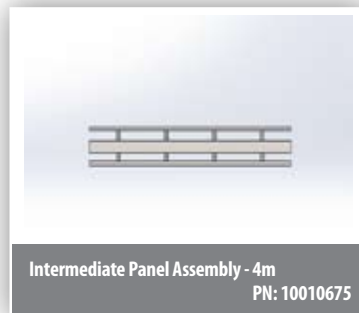
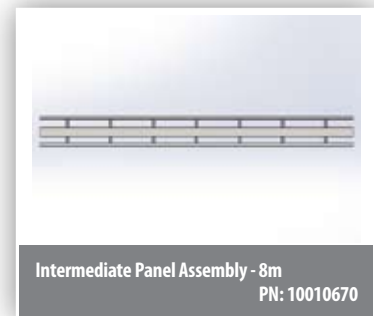

5.0 Recommended Tools

Documentation

- Assembly Manual (Most Current Version)
- System Drawing (Most Current Version)

Personal protective equipment (PPE)

- Safety Glasses
- Work Gloves
- Safety-Toe Shoes
- Back Protection
- Hard Hat
- Reflective Vest
- Hearing Protection



Miscellaneous

- Lifting Equipment and Procedures where components are up to 475kg each
- Torque Wrench to suit M24 and M16 up to 100Nm
- Traffic Control Equipment
- SAE Combination Wrench Set
- Socket Set & Socket Wrench
- Hammer
- Chalk Line and Tape Measure
- Marking Paint and Pen
- Straight Edge, Level and Plumb Line
- Post Pounder (commonly used for driving posts)
- Auger and Soil Tamper
- 5/8" Alignment Tool (Drift Pin)
- Locking Pliers and C-Clamps

Note: The above list of tools is a general recommendation only and should not be considered an exhaustive list.

Depending on specific site conditions and the complexity of the assembly (or repair) specified by the appropriate highway authority, additional or fewer tools may be required. Decisions as to what tools are needed to perform the job are entirely within the discretion of the specifying highway authority and the authority's selected contractor performing the assembly of the system at the authority's specified site.

6.0 Crash Test Analysis

Crash test guidelines provide a minimum set of requirements that a roadside barrier must meet in order to demonstrate its satisfactory impact performance.

Whilst crash test guidelines cannot include all possible impact conditions that may be experienced in the real world, the crash test matrix is selected to represent a “worst practical condition” for a roadside barrier impact.

The Ingal LSB has been fully crash tested and evaluated according to the specifications for Test Level 4 (TL4) of the AASHTO Manual for Assessing Safety Hardware (MASH).

In the revised standard AS/NZS 3845.1:2015, MASH has been nominated as the basis of testing procedures for road safety barrier systems.

The MASH TL4 crash test matrix requires the following impacts.

- Test 4-10, this is a 1,100kg car travelling at 100km/h and impacting the barrier at 25 degrees.
- Test 4-11, this is a 2,270kg utility travelling at 100km/h and impacting the barrier at 25 degrees.
- Test 4-12, this is a 10,000kg rigid truck travelling at 90km/h and impacting the barrier at 15 degrees.

Crash test impact conditions are defined by the mass, speed, and angle of the impacting vehicle. Crash test standards and performance levels can be compared by calculating the impact severity (IS).

$$IS = \frac{1}{2} M (V \sin \theta)^2$$

Where IS is the impact severity in joules (J), M is the test inertial mass of the vehicle in kilograms (kg), V is the impact speed in metres/second (m/s) and θ is the impact angle in degrees.

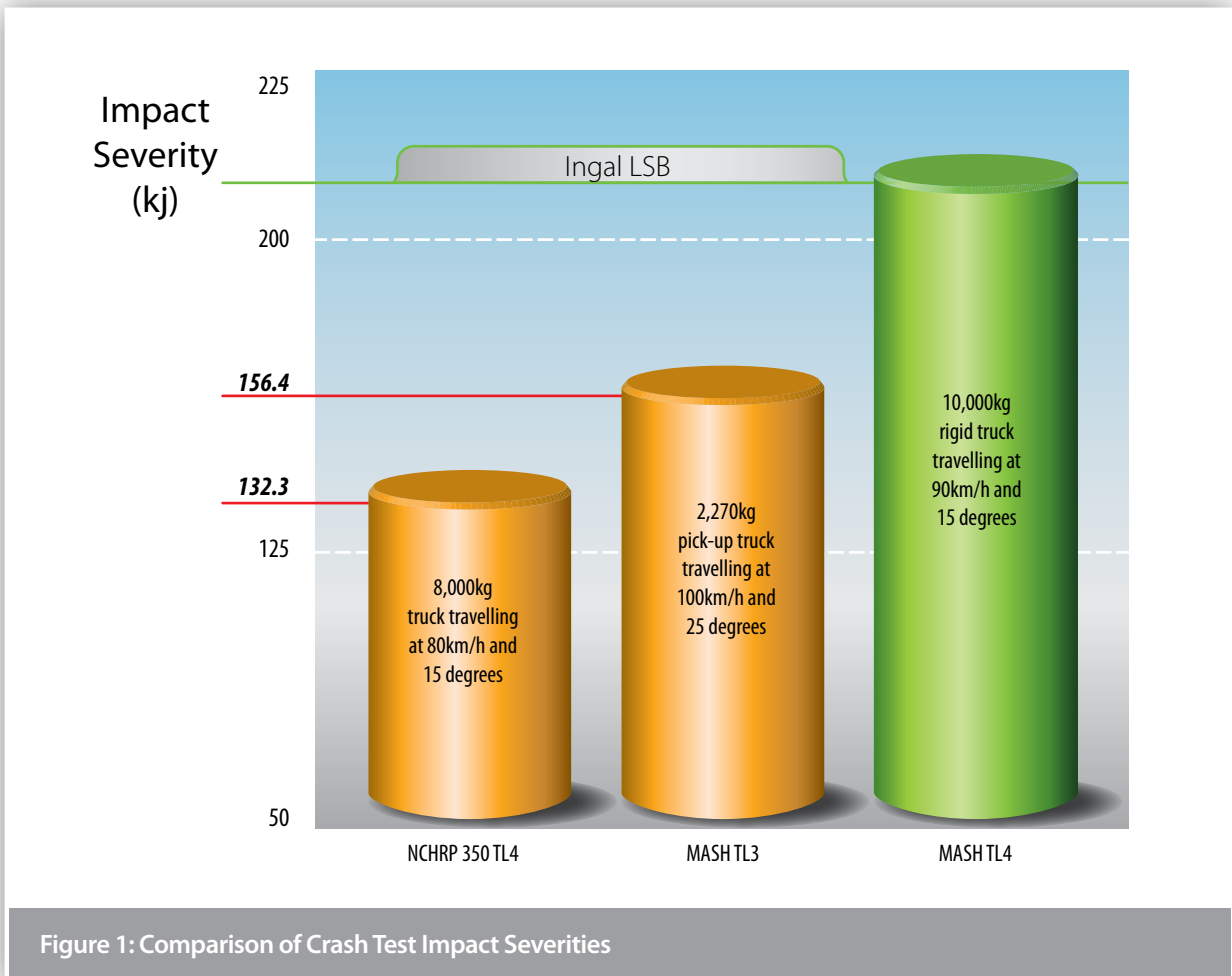

Figure 1: Comparison of Crash Test Impact Severities

Ingal LSB Long Span Barrier



MASH Crash Test Level 4-10: 1,100kg car at 100km/h and 25°



MASH Crash Test Level 4-11: 2,270kg pick-up truck travelling at 100km/h and 25 degrees



MASH Crash Test Level 4-12: 10,000kg rigid truck travelling at 90km/h and 15 degrees

7.0 Locally Designed & Produced

Ingal LSB is manufactured in Australia by Ingal Civil Products using steel manufactured by BlueScope Steel. Z-posts and rail are stamped providing traceability to material mechanical and chemical analysis certificates. Hot dip galvanising is performed internally by Ingal and daily inspections ensure zinc thickness readings are in accordance with AS/NZS standards..

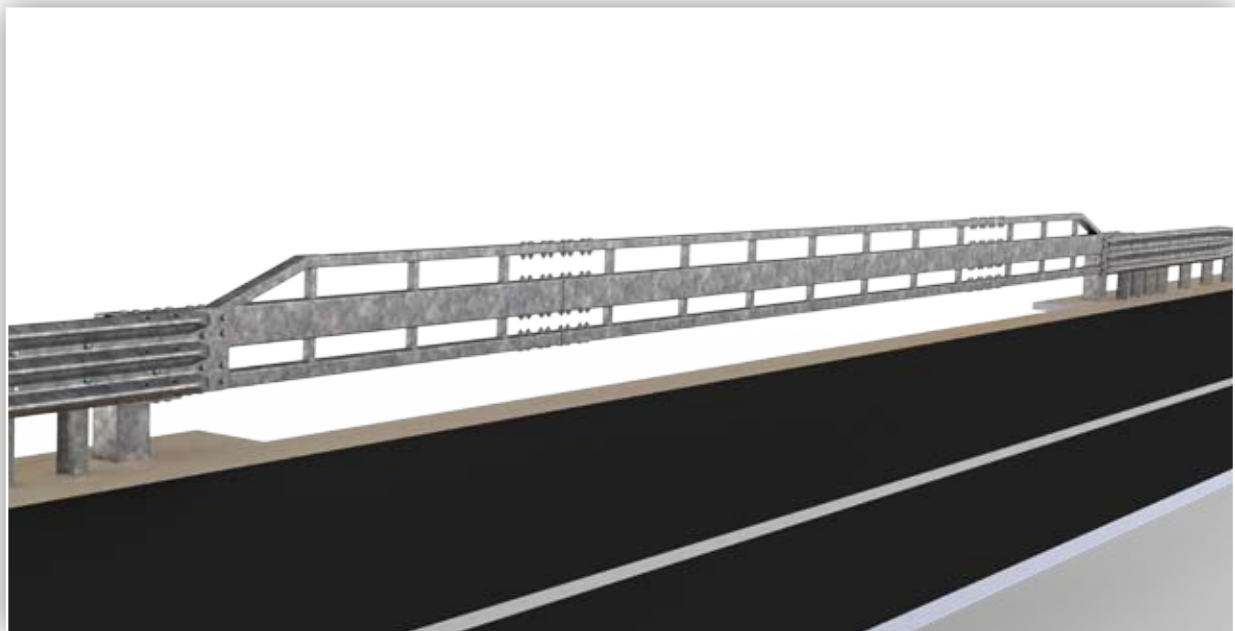

8.0 Installation

8.1. Bridges, Culverts and Causeways Application

Ingal LSB can be used for providing crash protection for bridges, culverts and causeways without applying load to the deck structure. In addition, the long-spanned ground clearance eliminates the capture of debris from an overflowing flood, which provides the benefits of low maintenance cost to prolong the lifespan of the barrier system.

When a 16m Ingal LSB is installed, the front/traffic face must overlap the edge of bridge/culvert/causeway deck by a minimum of 100mm. This is not required for systems of 14m or less in length. It is recommended that the Ingal LSB be at least 2m longer than the relevant structure. For example, a 16m Ingal LSB with a 14m culvert.

8.2. Non-Bridge Application

When the Ingal LSB is installed to protect a hazardous object on the side of the traffic lane, the clearance behind the barrier is required to be greater than the deflections shown in the deflection table (refer to Table 2).

8.3. Slopes

The maximum cross fall for an installation of the Ingal LSB is 10H:1V (10%).

8.4. Curving of Rails

Curving of the Rectangular Hollow Section Beams and Thriebeam rails within the Ingal LSB and RBT is not permitted. If additional offset of the barrier is required and the rigid structure cannot be moved, the offset should be attained in the longitudinal barrier.

8.5. Installation Height

The installation height of the Ingal LSB is 1150mm \pm 50mm from the road surface level.

8.6. Connection to Ezy-Guard 4 and Ezy-Guard HC

Ingal LSB can be connected to Ezy-Guard 4 through Ingal RBT transition which features a symmetrical transition panel that can be used for both leading and trailing locations.

A 4m Ezy-Guard 4 W-beam rail featuring a gradual decrease in post spacing is necessary after the Ingal RBT. Generally, this gradual decrease in the post spacing creates a smooth change of stiffness that helps with reducing the risk of vehicle pocketing, snagging or penetration at any point along the transition.



When connecting the Ingal LSB to Ezy-Guard HC, a smooth height transition that also provides gradual stiffening effect is required along with Ingal RBT.



The ET-SS End Terminal is required at the end of the run on both W-Beam and Thrie-Beam guardrails in order to make up a complete MASH compliant system. The end terminal not only provides anchorage to the system, it also provides crash safety at the end of the run, which eliminates the risk of spearing hazards.

8.7. End Terminal

The Ingal LSB can be connected to the ET-SS End Terminal directly through Ingal RBT with the symmetrical transition panels.



Figure 3: ET-SS Guardrail End Terminal

8.8. Minimum Installation Length

The Ingal LSB is designed to fit within a continuous Ezy-Guard 4 and Ezy-Guard HC guardrail system. When a continuous run of is not feasible, the minimum installation length of Ingal LSB can be achieved by connecting directly to the ET-SS End Terminal through Ingal RBT. However, the minimum installation length can vary depending on the design test level of the road and the length variant of the Ingal LSB used. Refer to tables below.

8.9 Delineation

A specially designed delineator is attached to the post. Typically, delineation is arranged so that drivers approaching from either direction will see only:

- Red retro-reflectors on their left;
- White retro-reflectors on their right on two-way carriageways; and
- Yellow retro-reflectors on their right on one-way carriageways and medians separating traffic in opposing directions.

The spacing of delineators is dependant upon driver line of sight and jurisdictional requirements. As a general rule delineators are provided for installation every 20m on straight alignments. Please refer to the asset owners specifications for further guidance.

Table 3: Road with speed less than or equal to 70km/h

Ingal LSB Variant	with	2 x ET-SS End Terminal (MASH TL2)	with	2 x Ingal RBT Transition	Minimum Installation Length
8m TBC	+	2 x 7.9m	+	2 x 6m	35.8m
10m TBC					37.8m
12m TBC					39.8m
14m TBC					41.8m
16m					43.8m

Table 4: Road with speed greater than 70km/h

Ingal LSB Variant	with	2 x ET-SS End Terminal (MASH TL3)	with	2 x Ingal RBT Transition	Minimum Installation Length
8m TBC	+	2 x 15.5m	+	2 x 6m	51m
10m TBC					53m
12m TBC					55m
14m TBC					57m
16m					59m

8.10 Modifications

The Ingal LSB shall be constructed in the configuration as detailed in Ingal Civil Products' drawings. This is the configuration in which the system has been crash tested.

No modifications shall be made to the system unless verified by Ingal Civil Products. Flame cutting of panels or posts is not permitted.

Any modification carried out after fabrication will require repair to the galvanized coating. This is undertaken by applying two coats of an organic zinc rich epoxy paint complying with AS/NZS 3750.9. This is to be applied to the repair areas in two coats. Each coat shall have a minimum dry film thickness of 50 µm.

8.11 Curving of Panels

Curving of the panels within the Ingal LSB and Ingal RBT is not permitted. If additional offset of the barrier is required and the rigid structure cannot be moved, the offset should be attained in the longitudinal barrier.

8.12 Installation Soil Conditions

The Ingal LSB must be installed in minimum AASHTO standard soil using augured holes and in-situ concrete footings. For sites with extreme soil conditions, consult Ingal Civil Products.

9.0 Installation Sequence

The following written instructions should be read in conjunction with Ingal Civil Products' drawings.

A generic Safe Work Method Statement is available from Ingal Civil Products to assist in the safe installation of the Ingal LSB.

Only items purchased from Ingal Civil Products shall be used for the construction of the Ingal LSB.

- 9.1 Ensure the area has been inspected for underground hazards and that suitable traffic control is in place
- 9.2 Locations of the Ingal LSB posts are marked depending on the length variant in accordance with the drawings at the end of this manual. Avoid any underground hazard as possible. If underground hazard can not be avoided, please contact Ingal Civil Product for advice.
- 9.3 Drill a 750mm diameter hole to the depth of 1800mm with the centre of the hole being the centre of the Ingal LSB post.

9.4 For all variants other than the 8m:

- 9.4.1 Place the installation stand on either side of the mid-point of the installation, with the distance in between being slightly less than the middle panel that will be installed.
- 9.4.2 Place the middle panel on the stands, align the position to match the desired installation position according to the drawing. Be aware that the beam of the top layer is slightly narrower than the second layer and the bottom layer.
- 9.4.3 Insert the beam joiners into all three layers of beams. Make sure correct joiners are used for each layer and the orientation of the joiners are as shown in the drawing.
- 9.4.4 Insert the correct fasteners to secure all six joiners on both sides of the middle panel. Hand-tighten the nuts to prevent detaching of the fasteners. Make sure correct washers are used.
- 9.4.5 Place one stand on either side of the middle panel to support the side panels.
- 9.4.6 Connect one side panel to the middle panel by pushing the end panel over the joiners, insert corresponding fasteners and hand-tighten the nuts. The side panel is symmetrical through its centre plane so it can be used on both approaching and trailing ends.
- 9.4.7 Repeat step 9.4.6 for the remaining side panel.
- 9.4.8 Tighten all fasteners that are already installed to the designed torque spec, 100Nm for M24 threads.
- 9.4.9 Insert joiners to the very end of each side panel. For each side, install the two vertical fasteners that are close to the middle point and tighten the nuts to 100Nm.
- 9.4.10 Put on the end RHS pieces onto the joiners at the very ends of the Ingal LSB to close off the exposed joiners. Make sure that the position of the bolt holes on the end pieces are aligned with that on the joiners.



Figure 4: Ingal LSB installation direction for all variants other than the 8m

9.5 For 8m variant

- 9.5.1 Place two stands to support each of the side panels.
- 9.5.2 Insert the beam joiners into all three layers of beams. Make sure correct joiners are used for each layer and the orientation of the joiners are as shown in the drawing.
- 9.5.3 Insert the beam joiners into all three layers of beams of one side panel. Make sure correct joiners are used for each layer and the orientation of the joiners are as shown in the drawing.
- 9.5.4 Insert the correct fasteners to secure all three joiners. Hand-tighten the nuts to prevent detaching of the fasteners. Make sure correct washers are used.
- 9.5.5 Push the other side panel over the joiners and insert corresponding fasteners.
- 9.5.6 Tighten the nuts to 100Nm to secure the connection between the two side panels.
- 9.5.7 Insert joiners to the very end of each side panel. For each side, install the two vertical fasteners that are close to the middle point and tighten the nuts to 100Nm.
- 9.5.8 Put on the end RHS pieces onto the joiners at the very ends of the Ingal LSB to close off the exposed joiners. Make sure that the position of the bolt holes on the end pieces are aligned with that on the joiners.

For all variants

- 9.6 Place the footing reinforcement cage into the 750mm diameter ground hole.
- 9.7 Position the post into the ground hole, align its bolt holes with the side panels.
- 9.8 Inserting all the remaining vertical fasteners, leave them hand tightened.
- 9.9 Place the connecting plate onto the front face of the panels, align the holes and insert the M16 x 450mm bolts that go through the post. Hand-tighten the nuts.
- 9.10 Tighten all installed fasteners to the designated torque spec M24 = 100Nm, M16 = 95Nm.
- 9.11 Now all major components are assembled, adjust the final position of the Ingal LSB if necessary. Reposition the stands to accommodate the adjusted positions.
- 9.12 Pour 32Mpa concrete into the post hole. The reinforcement cage should be positioned about 100mm above the bottom of the hole and be fully submerged by the concrete. If excessive concrete is used to finish off the road surface, doing so will not affect the performance of the Ingal LSB.
- 9.13 Allow the Ingal LSB to be supported by the installation stand for a minimum of 24 hours in order to allow concrete to cure.
- 9.14 Install Ingal RBT on both ends of the Ingal LSB.

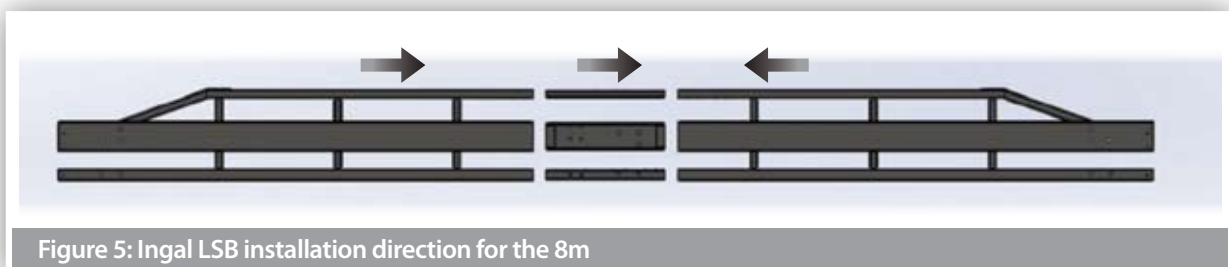

Figure 5: Ingal LSB installation direction for the 8m

10.0 Maintenance

It is recommended that annual inspections be performed to ensure the following;

- Concrete footing is fully embedded in the soil;
- Debris has not accumulated around the system that may impede the performance of the barrier or the trajectory of an impacting vehicle;
- The system is suitably anchored with appropriate terminals and/or transitions. If the system is anchored with terminals, the Anchor and/or Cable Assemblies shall be taut and installed as per system requirements; and
- All splice bolts, post bolts and assembly bolts are snug tight.

11.0 Product Storage

All components of the Ingal LSB are hot dip galvanized in accordance with AS/NZS 4680. It is important that stored galvanized work is stacked so that each item is well ventilated and can adequately drain rainwater from its surfaces. Poor storage can give rise to wet storage stain (white rust) which is caused by water (rain or condensation) in badly drained or ventilated conditions. This can occur very quickly, particularly in warm, humid conditions.

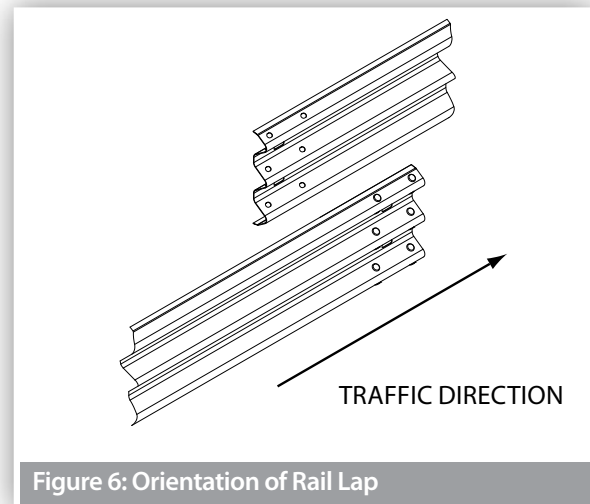

Figure 6: Orientation of Rail Lap

12.0 Repair

12.1 Post Impact Assessment and Repair

The Ingal LSB's modular design allows for quick and affordable repairs. After a vehicle impact, it's often the case that not all panels and/or posts are damaged. As only damaged panels and/or posts and fasteners require replacement, repairs may be performed in a timely and cost effective manner without replacing the entire system.

After the MASH 4-10 test (1100kg car, 100 km/hr, 25 degree), the LSB's panels and anchor posts were undamaged, and were subsequently reused for the MASH 4-11 test (2270kg pickup truck, 100 km/hr, 25 degree).

The general damage assessment and repair procedure is detailed in Table 5. When the damage is less than what is described in Table 5, the replacement of components may not be required and the system may not require dismantling. In this case, the LSB may only require straightening and the surrounding material (soil) of the anchor posts require re-compaction.

Any item which has been dismantled or replaced is to be reinstated in accordance with the installation tolerances nominated in Section 9.0.

Only items purchased from Ingal Civil products shall be used for repair of the LSB, connecting transitions, Intermediate Guardrail and End Terminals.

12.2 Dismantling Sequence

Prior to undertaking dismantling due to a vehicle impact, the area should be assessed for hazards. These include trip hazards, sharp edges and snag points.

During a vehicle impact, the panels of the Ingal LSB will flex and deform as the system absorbs the kinetic energy from the impacting vehicle.

The recommended dismantling sequence is as follows:

1. If necessary, under the safe condition, use a crane or installation stand (if possible), to support the weight of the beam panels.
2. Dismantle the connection bolts between Ingal RBT and Ingal LSB on both approach and trailing sides.
3. Remove the thriebeam rail and the thriebeam terminal connector of the Ingal RBT to provide space in order to work on the Ingal LSB panels.
4. Loosen the connection between beam panels and the main post by dismantling the connection bolts.
5. Carefully place the beam panels on the ground.
6. Disassemble the beam panels by removing the assembly bolts.
7. Remove the soiling around the concrete footing then the main post can be removed from the ground.



Figure 7: No damage after MASH 4-10 Test

12.3 Bush Fire Damage

The Ingal LSB does not contain any plastic, timber or rubber components that will burn.

The performance of galvanized coatings when subjected to fires depends upon a number of factors, such as flame duration and intensity.

12.4 Recycling of Ingal LSB

Other than the concrete footing which is required to anchor the main post, the Ingal LSB is fully constructed with sustainable steel, which means the recycling process is straightforward and environmentally friendly.



Ingal LSB uses recyclable steel

Table 5: Damage Assessment of Ingal LSB

Type of Defect	Description of the Defect	Action to be Taken
Galvanizing damage on Ingal LSB individual panel components (side panel and mid panel).	The sum total of the damaged area does not exceed 150cm ² and individual damaged does not exceed 60cm ² The sum total of the damaged area exceeds 150cm ² and/or a n individual damaged area exceeds 60cm ²	An organic zinc rich epoxy paint is to be applied to the repair area in two coats as per AS/NZS 4680. The Ingal LSB panel component is to be replaced..
Galvanizing damage on Ingal LSB anchor posts.	The sum total of the damaged area does not exceed 200cm ² and individual damaged does not exceed 60cm ² The sum total of the damaged area exceeds 200cm ² and/or a n individual damaged area exceeds 60cm ²	An organic zinc rich epoxy paint is to be applied to the repair area in two coats as per AS/NZS 4680. The Ingal LSB anchor post is to be replaced along with the concrete foundation.
Galvanizing damage on Z-Posts.	The sum total of the damaged area does not exceed 35cm ² (0.5% of the total surface area). The sum total of the damaged area exceeds 35cm ²	An organic zinc rich epoxy paint is to be applied to the repair area in two coats as per AS/NZS 4680. The Z-post is to be replaced.
Galvanizing damage on guardrail transitions.	The sum total of the damaged area does not exceed 200cm ² (0.5% of the total surface area) and individual damaged area does not exceed 40cm ² . The sum total of the damaged area exceeds 200cm ² (0.5% of the total surface area) and/or an individual damaged area exceeds 40cm ² .	An organic zinc rich epoxy paint is to be applied to the repair area in two coats as per AS/NZS 4680. The rail is to be replaced.
Mechanical damage to Ingal LSB rail section.	Permanent deformation on vertical or lateral axis is less than 100mm. Permanent deformation on vertical or lateral axis exceeds 100mm.	Loosen the connection bolts near the deformation and pull the panels straight then tighten the bolts. The Ingal LSB rail is to be replaced.
Mechanical damage to anchor posts.	The post is bent. The post is twisted.	The post is to be replaced. The post is to be replaced.
Mechanical damage on Z-Posts.	The post is bent. The post is twisted.	The post is to be replaced. The post is to be replaced.
Mechanical damage on guardrail transitions.	The rail is dented, twisted or flattened. There are tears in any part of the rail. The slots in the rail are distorted.	The rail is to be replaced. The rail is to be replaced. The rail is to be replaced.
Mechanical damage on bolts.	The body of the bolt is distorted. The thread of the bolt is damaged.	The bolt is to be replaced. The bolt is to be replaced.
Damage/Disturbance to concrete footing of post.	The concrete footing is cracked.	Replace concrete footing.
Disturbance of material around posts.	The material (e.g. soil) surrounding the concrete foundation of the anchor post is loose or uncompacted.	Any disturbed pavement or material surrounding the concrete foundation of the anchor post is to be returned to its original state before the impact.

13.0 Ingal LSB Installation Checklist

Customer:

Project:

Barrier ID:

Barrier Length:

Checked By:

Signed:

Date

Have the posts been positioned in accordance with the Ingal LSB drawings	<input type="checkbox"/> Yes	<input type="checkbox"/> No
Is the concrete footing constructed in the correct dimension	<input type="checkbox"/> Yes	<input type="checkbox"/> No
Posts are installed in the correct height (850mm above ground) and within the tolerance of section 9.0	<input type="checkbox"/> Yes	<input type="checkbox"/> No
Are the end sleeve pieces installed on the very ends of the beam panels near anchor post?	<input type="checkbox"/> Yes	<input type="checkbox"/> No
Is connecting plate used to connect Ingal LSB to Ingal RBT	<input type="checkbox"/> Yes	<input type="checkbox"/> No
Is the connecting plate connected to the Ingal RBT by 9 bolts in total	<input type="checkbox"/> Yes	<input type="checkbox"/> No
Have the correct fasteners been used in accordance with the Ingal LSB drawings	<input type="checkbox"/> Yes	<input type="checkbox"/> No
Have the fasteners been taut to its designed torque spec, 95Nm for M16 and 100Nm for M24	<input type="checkbox"/> Yes	<input type="checkbox"/> No
Are the fasteners on the Ingal LSB behind the Thrie-Beam rails correctly installed	<input type="checkbox"/> Yes	<input type="checkbox"/> No
Have the rails been spliced observing the correct lap	<input type="checkbox"/> Yes	<input type="checkbox"/> No
Have the rails been spliced with M16x32mm mushroom head bolts and tightened to snug	<input type="checkbox"/> Yes	<input type="checkbox"/> No
Is the upstream end of the run of barrier anchored with approved terminal	<input type="checkbox"/> Yes	<input type="checkbox"/> No
Where applicable, is the terminal cable tensioned to it's nominated torque (taut)	<input type="checkbox"/> Yes	<input type="checkbox"/> No
Has any minor damage been repaired using two coats of an organic zinc rich paint	<input type="checkbox"/> Yes	<input type="checkbox"/> No
Does the barrier form a smooth line vertically and horizontally when viewed along the system	<input type="checkbox"/> Yes	<input type="checkbox"/> No
Is the barrier system free from humps, sags or other irregularities	<input type="checkbox"/> Yes	<input type="checkbox"/> No
Has the ground or pavement around the post been left dense, tight and smooth	<input type="checkbox"/> Yes	<input type="checkbox"/> No
Are the barrier components free from splits, burrs or sharp edges after installation	<input type="checkbox"/> Yes	<input type="checkbox"/> No

Disclaimer:

Important Note: The conformity of the installation is the responsibility of the installation contractor, and Ingal Civil Products accepts no liability for or in connection with any installation that is outside of the specifications of this manual or the Road Controlling Authority. For more information, please refer to our Standard Terms and Conditions of Sale available on our website: www.ingalcivil.com.au.

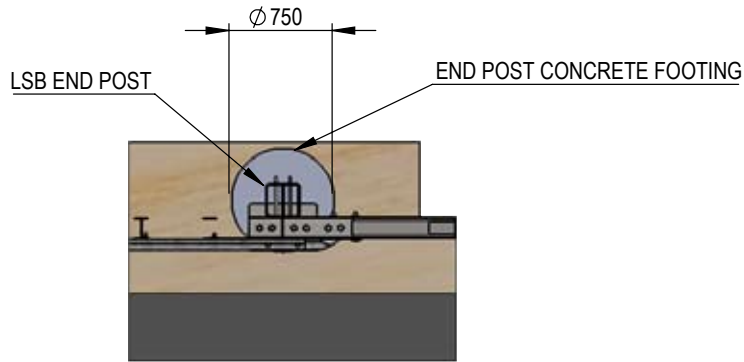
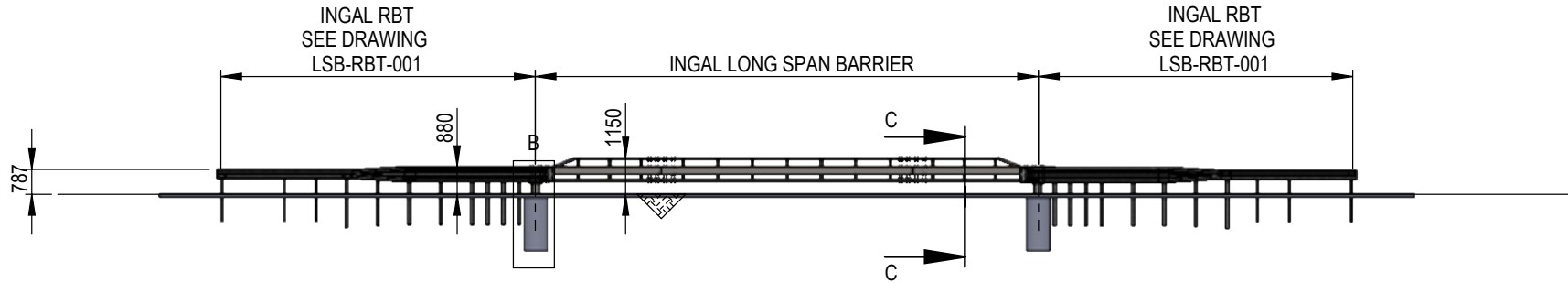
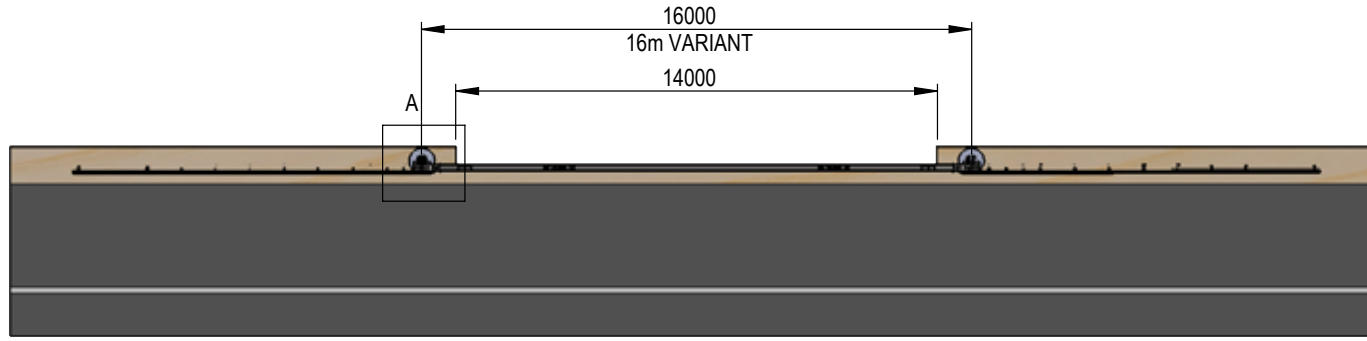

DETAIL A
SCALE 1 : 50

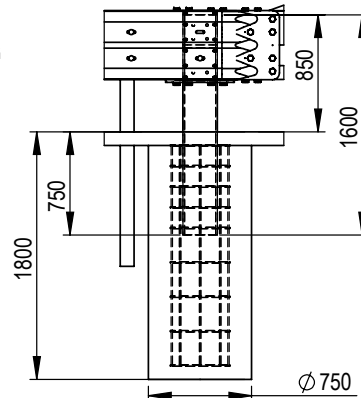

DETAIL B
SCALE 1 : 50

CULVERT EDGE OFFSET
100mm BEHIND THE FRONT
FACE OF THE INGAL LSB

FRONT OF LSB
FACING ROAD

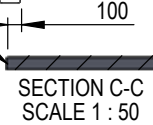

SECTION C-C
SCALE 1 : 50

REV.	DATE	DESCRIPTION	DRAWN	CHECKED	APPROVED

DRAWING NUMBER	REFERENCE DRAWINGS

NAME	DATE
DRAWN KZ	31/10/2023
CHECKED LB	31/10/2023
APPROVED LB	31/10/2023
SCALE 1:200	SHEET: 1 of 1
ISSUE FOR	

INGAL CIVIL PRODUCTS
A valmont COMPANY

DRAWING AND CONTENTS ARE COPYRIGHT TO
INGAL CIVIL PRODUCTS AND CAN ONLY BE USED
WITH PRIOR WRITTEN CONSENT FROM INGAL CIVIL
PRODUCTS

57 AS AMOS ROAD
MUNGO, N.S.W 2566
PH +61 2 9697 3333
www.ingalcivil.com.au

PROJECT	TITLE
	INGAL LONG SPAN BARRIER - 16m LAYOUT

INGAL CIVIL PRODUCTS PART No. -	DRAWING No. LSB-STD-011
	Rev: 0

FOLDER: F:\ENGINEERING\4. DRAWINGS IN PROGRESS\SOLIDWORKS MODEL IN PROGRESS\INGAL\CURRENT\..._MODEL\CONCEPT 11 SIM MODEL

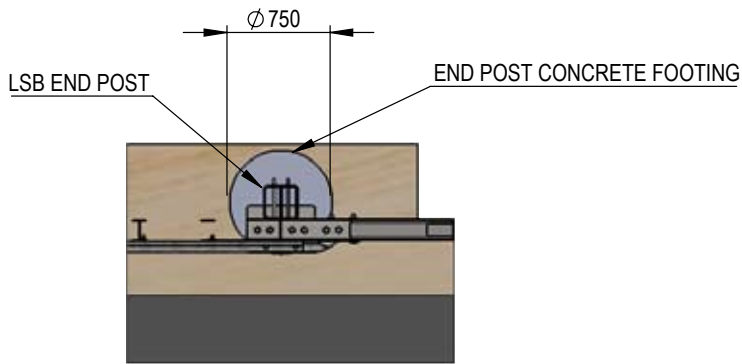
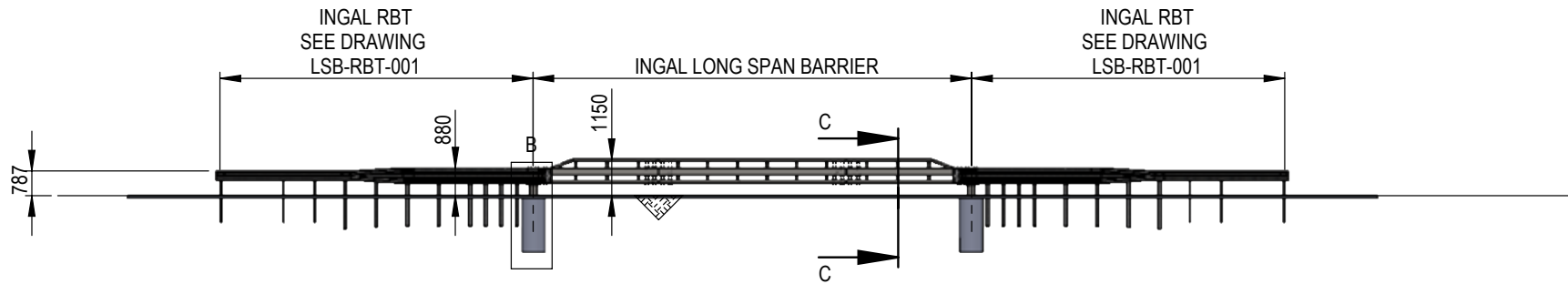
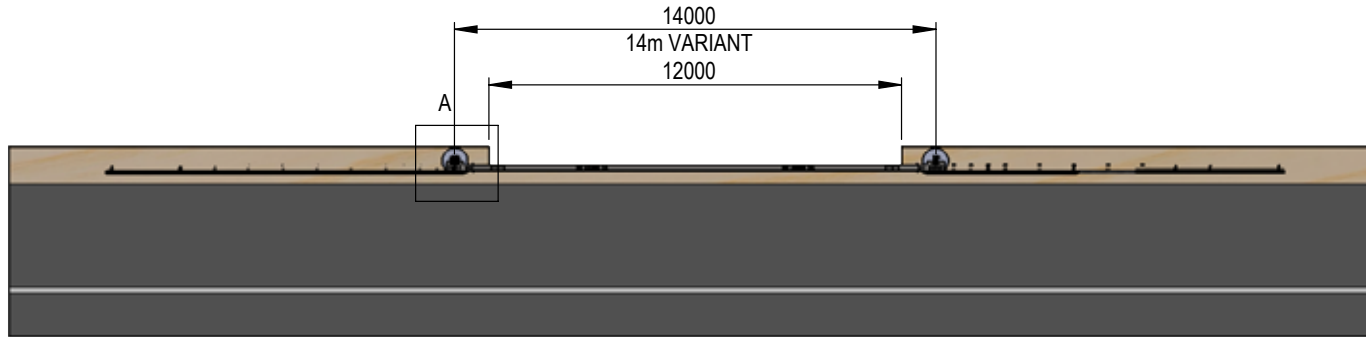

DETAIL A
SCALE 1 : 50

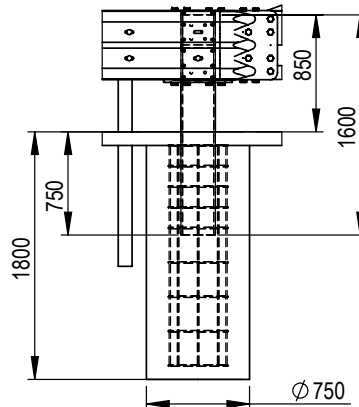

DETAIL B
SCALE 1 : 50

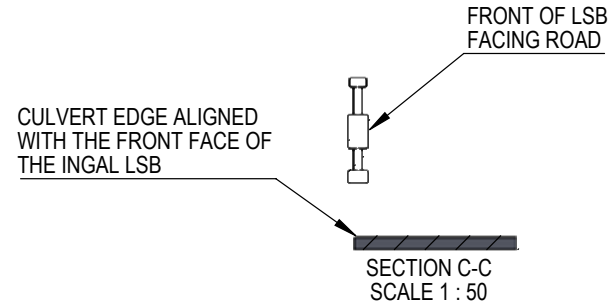

SECTION C-C
SCALE 1 : 50

REV.	DATE	DESCRIPTION	DRAWN	CHECKED	APPROVED

DRAWING NUMBER	REFERENCE DRAWINGS

	NAME	DATE
DRAWN	KZ	31/10/2023
CHECKED	LB	31/10/2023
APPROVED	LB	31/10/2023
SCALE	1:200	SHEET: 1 of 1
ISSUE FOR		

INGAL CIVIL PRODUCTS
A valmont COMPANY

DRAWING AND CONTENTS ARE COPYRIGHT TO
INGAL CIVIL PRODUCTS AND CAN ONLY BE USED
WITH PRIOR WRITTEN CONSENT FROM INGAL CIVIL
PRODUCTS

57-55 AMERS ROAD
MUNTO, N.S.W 2566

PH +61 2 9697 3333
www.ingalcivil.com.au

PROJECT	TITLE
	INGAL LONG SPAN BARRIER - 14m LAYOUT

INGAL CIVIL PRODUCTS PART No.	DRAWING No.	Rev.
-	LSB-STD-015	0

FOLDER: F:\ENGINEERING\4. DRAWINGS IN PROGRESS\SOLIDWORKS MODEL IN PROGRESS\ISSUATOR\CURRENT\..._MODEL\CONCEPT 11 SIM MODEL

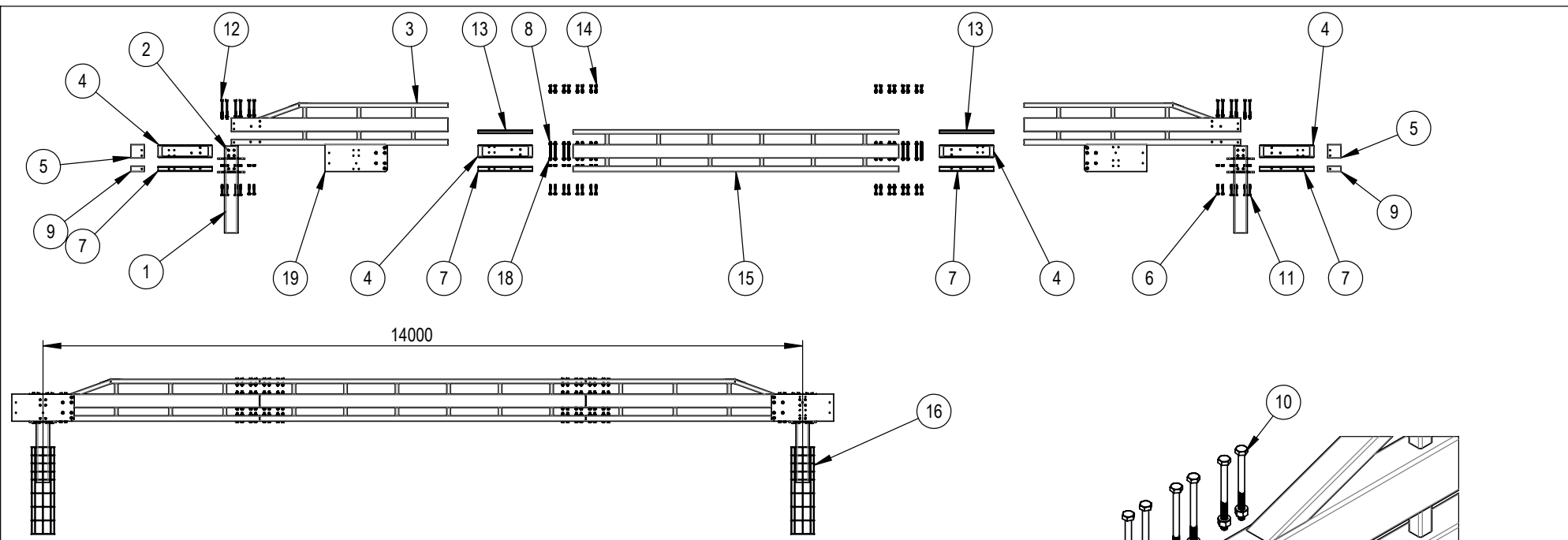

ID	DESCRIPTION	PART NO.	QTY.
1	ANCHOR POST ASSEMBLY	10010668	2
2	M16 x 450 STRUCTURAL BOLT NUT WASHER SET - GRADE 8.8 TO AS1252 K0 CLASS	10010511	12
3	LEADING-TRAILING PANEL ASSEMBLY	10010669	2
4	MID BEAM JOINER	10010671	4
5	RHS - 250 x 150 x 5 - 245mm	10010648	2
6	M24 x 150 STRUCTURAL BOLT - GRADE 8.8 TO AS1252 K0 CLASS	10010513	20
7	LOWER BEAM JOINER	10010672	4
8	M24 x 330 THREADED ROD - GRADE 8.8 TO AS1252 K0 CLASS	10010568	16
9	RHS - 150 x 100 x 4 - 245mm	10010647	2
10	M24 x 300 STRUCTURAL BOLT NUT WASHER SET - GRADE 8.8 TO AS1252 K0 CLASS	10010514	4
11	M24 x 170 STRUCTURAL BOLT - GRADE 8.8 TO AS1252 K0 CLASS	10010567	8
12	M24 x 330 STRUCTURAL BOLT NUT WASHER SET - GRADE 8.8 TO AS1252 K0 CLASS	10010569	8
13	UPPER BEAM JOINER	10010673	2
14	M24 x 120 STRUCTURAL BOLT NUT WASHER SET - GRADE 8.8 TO AS1252 K0 CLASS	10010566	16
15	INTERMEDIATE PANEL ASSEMBLY - 6M	10010674	1
16	CONCRETE FOOTING REO BAR	10010554	2
17	NORD LOCK WASHER M24 - NL24SP GRADE 8.8	10010570	88
18	M24 STRUCTURAL NUT - GRADE 8.8 TO AS1252 K0 CLASS	10002169	60
19	INGAL LONG SPAN BARRIER CONNECTION PLATE	10010684	2
20	M24 x 200 STRUCTURAL BOLT NUT WASHER SET - GRADE 8.8 TO AS1252	10002171	8
21	M24 x 50mm BOLT NUT SET - GRADE 8.8	10009685	4

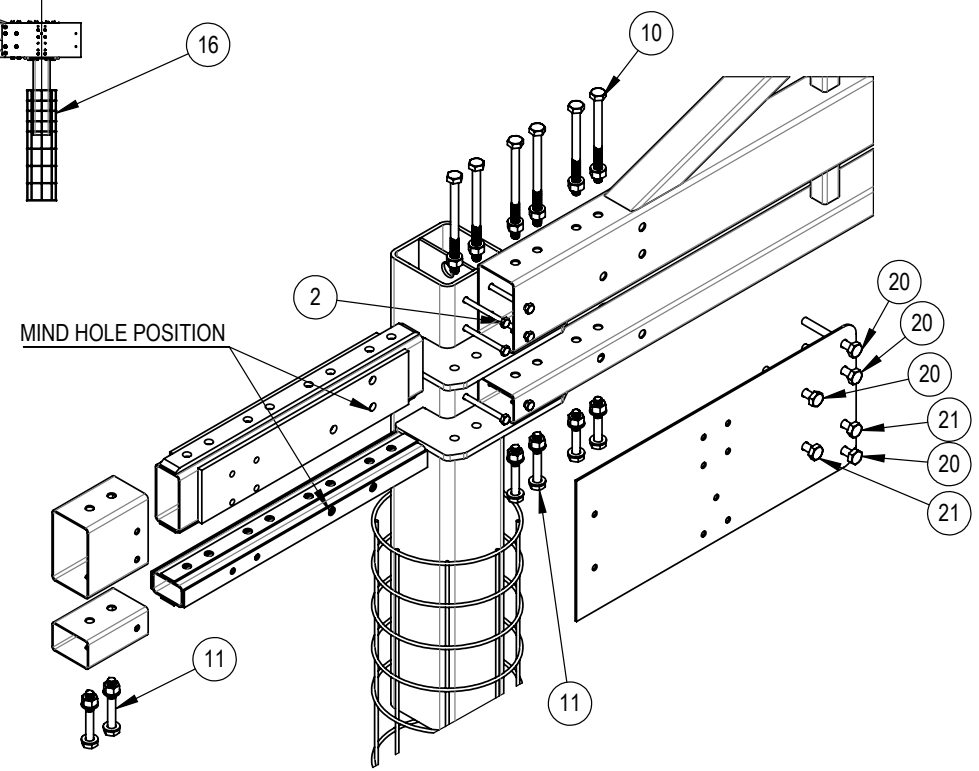

REV.	DATE	DESCRIPTION	DRAWN	CHECKED	APPROVED

NAME	DATE
DRAWN KZ	22-06-2023
CHECKED LB	31/10/2023
APPROVED LB	31/10/2023
SCALE	1:100
SHEET	1 of 1
ISSUE FOR	

	PROJECT	INGAL LONG SPAN BARRIER COMPONENTS - 14M
	TITLE	INGAL LONG SPAN BARRIER COMPONENTS - 14M

INGAL CIVIL PRODUCTS PART No.	10010678
DRAWING No.	LSB-STD-002
Rev.	0

FOLDER: F:\ENGINEERING\4. DRAWINGS IN PROGRESS\SOLIDWORKS MODEL IN PROGRESS\GATOR\CURRENT\1_MODEL\CONCEPT 11 SIM MODEL

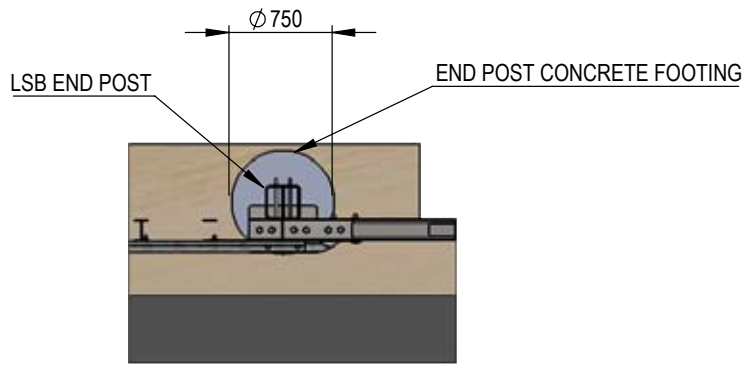
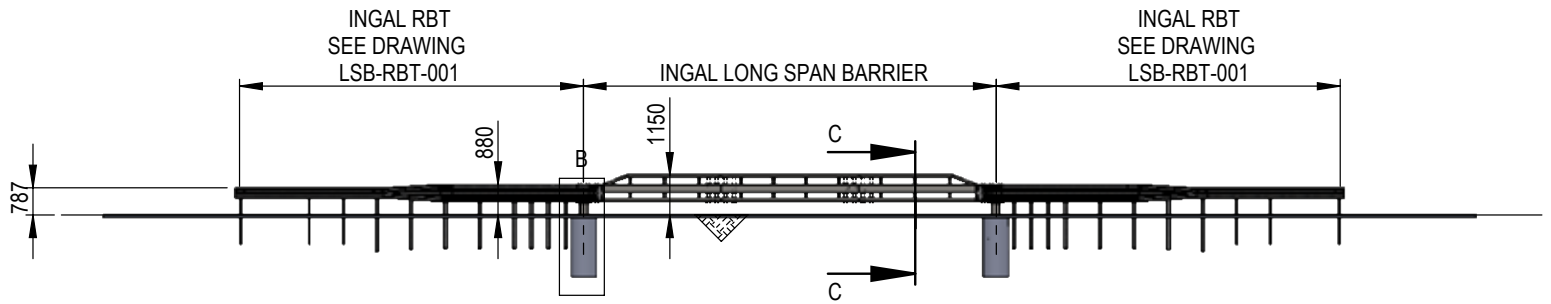
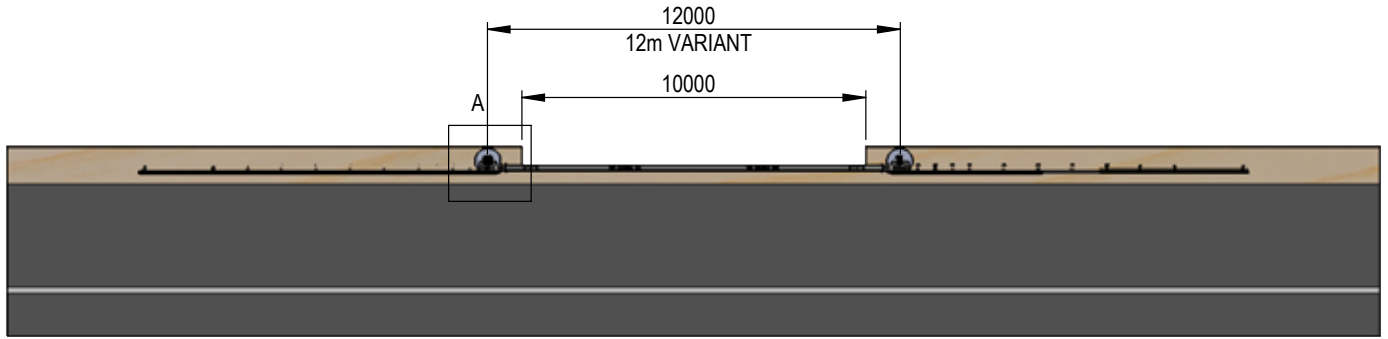

DETAIL A
SCALE 1 : 50

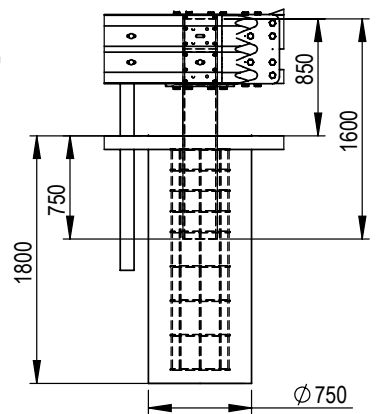

DETAIL B
SCALE 1 : 50

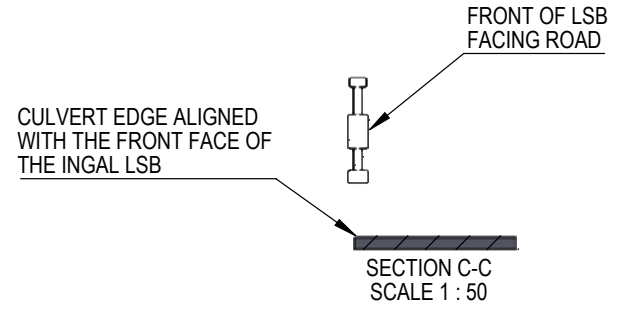

REV.	DATE	DESCRIPTION	DRAWN	CHECKED	APPROVED

DRAWING NUMBER	REFERENCE DRAWINGS

	NAME	DATE
DRAWN	KZ	31/10/2023
CHECKED	LB	31/10/2023
APPROVED	LB	31/10/2023
SCALE	1:200	SHEET: 1 of 1
ISSUE FOR		

INGAL CIVIL PRODUCTS
A valmont COMPANY

DRAWING AND CONTENTS ARE COPYRIGHT TO INGAL CIVIL PRODUCTS AND CAN ONLY BE USED WITH PRIOR WRITTEN CONSENT FROM INGAL CIVIL PRODUCTS.

57 AS AMOS ROAD
MUNGO, N.S.W 2566
PH +61 2 9697 3333
www.ingalcivil.com.au

PROJECT	TITLE
	INGAL LONG SPAN BARRIER - 12m LAYOUT

INGAL CIVIL PRODUCTS PART No.	DRAWING No.	Rev.
-	LSB-STD-016	0

FOLDER: F:\ENGINEERING\4. DRAWINGS IN PROGRESS\SOLIDWORKS MODEL IN PROGRESS\ISSUATOR\CURRENT\TY...MODEL\CONCEPT 11 SIM MODEL

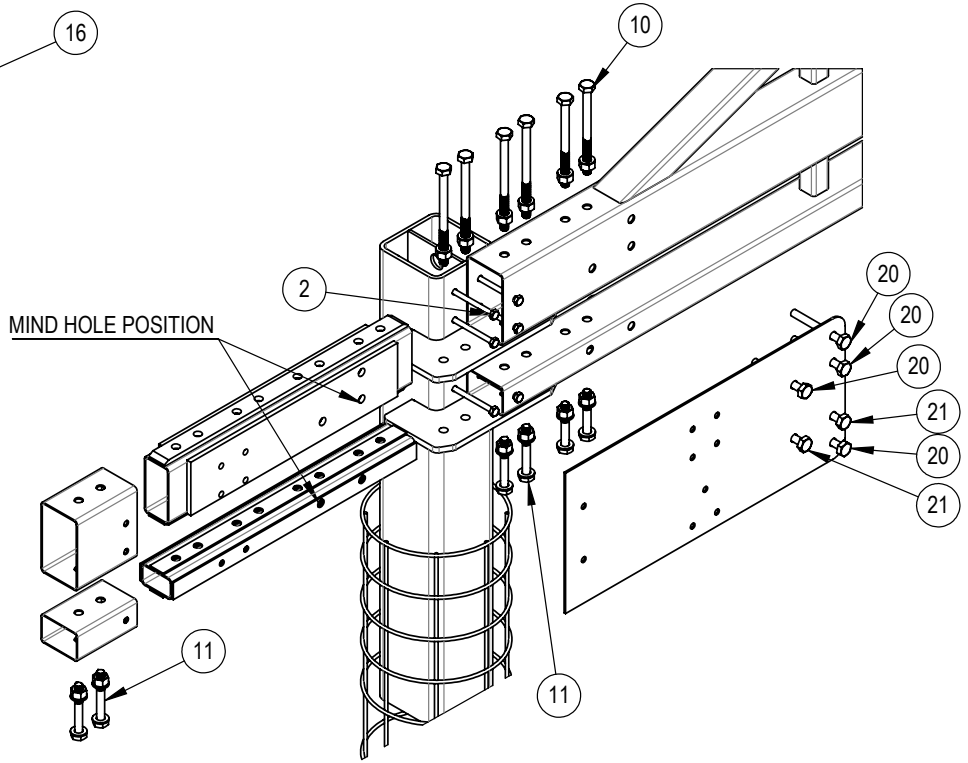
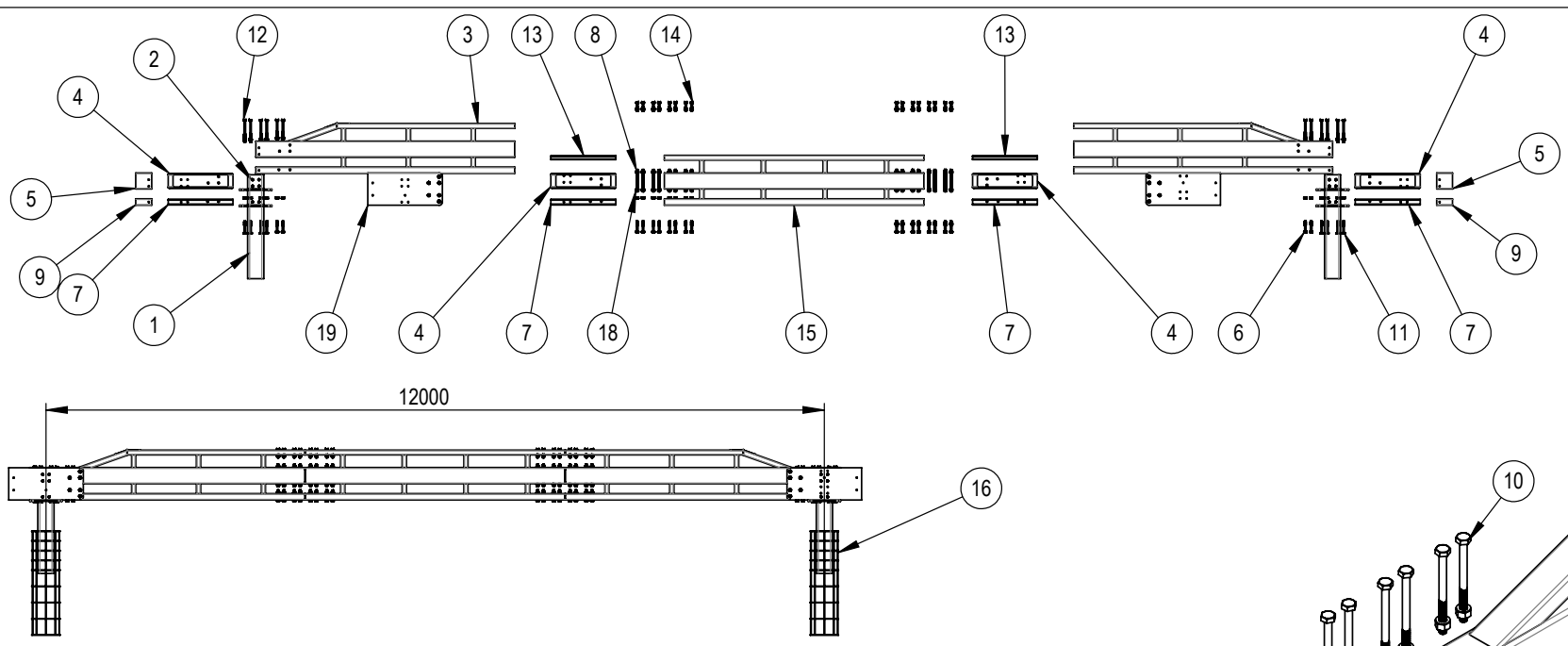

ID	DESCRIPTION	PART NO.	QTY.
1	ANCHOR POST ASSEMBLY	10010668	2
2	M16 x 450 STRUCTURAL BOLT NUT WASHER SET - GRADE 8.8 TO AS1252 K0 CLASS	10010511	12
3	LEADING-TRAILING PANEL ASSEMBLY	10010669	2
4	MID BEAM JOINER	10010671	4
5	RHS - 250 x 150 x 5 - 245mm	10010648	2
6	M24 x 150 STRUCTURAL BOLT - GRADE 8.8 TO AS1252 K0 CLASS	10010513	20
7	LOWER BEAM JOINER	10010672	4
8	M24 x 330 THREADED ROD - GRADE 8.8 TO AS1252 K0 CLASS	10010568	16
9	RHS - 150 x 100 x 4 - 245mm	10010647	2
10	M24 x 300 STRUCTURAL BOLT NUT WASHER SET - GRADE 8.8 TO AS1252 K0 CLASS	10010514	4
11	M24 x 170 STRUCTURAL BOLT - GRADE 8.8 TO AS1252 K0 CLASS	10010567	8
12	M24 x 330 STRUCTURAL BOLT NUT WASHER SET - GRADE 8.8 TO AS1252 K0 CLASS	10010569	8
13	UPPER BEAM JOINER	10010673	2
14	M24 x 120 STRUCTURAL BOLT NUT WASHER SET - GRADE 8.8 TO AS1252 K0 CLASS	10010566	16
15	INTERMEDIATE PANEL ASSEMBLY - 4M	10010675	1
16	CONCRETE FOOTING REO BAR	10010554	2
17	NORD LOCK WASHER M24 - NL24SP GRADE 8.8	10010570	88
18	M24 STRUCTURAL NUT - GRADE 8.8 TO AS1252 K0 CLASS	10002169	60
19	INGAL LONG SPAN BARRIER CONNECTION PLATE	10010684	2
20	M24 x 200 STRUCTURAL BOLT NUT WASHER SET - GRADE 8.8 TO AS1252	10002171	8
21	M24 x 50mm BOLT NUT SET - GRADE 8.8	10009685	4

REVISIONS REV. DATE DESCRIPTION DRAWN CHECKED APPROVED						PROJECT INGAL CIVIL PRODUCTS PART No. 10010679 TITLE INGAL LONG SPAN BARRIER COMPONENTS - 12M DRAWING No. LSB-STD-003 Rev. 0

PROJECT
 INGAL CIVIL PRODUCTS PART No. 10010679
 TITLE
 INGAL LONG SPAN BARRIER COMPONENTS - 12M
 DRAWING No. LSB-STD-003
 Rev. 0

FOLDER: F:\ENGINEERING\4. DRAWINGS IN PROGRESS\SOLIDWORKS MODEL IN PROGRESS\GATOR\CURRENT\1_MODEL\CONCEPT 11 SIM MODEL

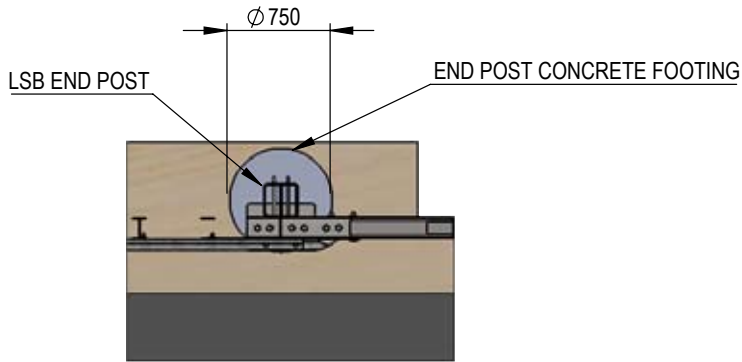
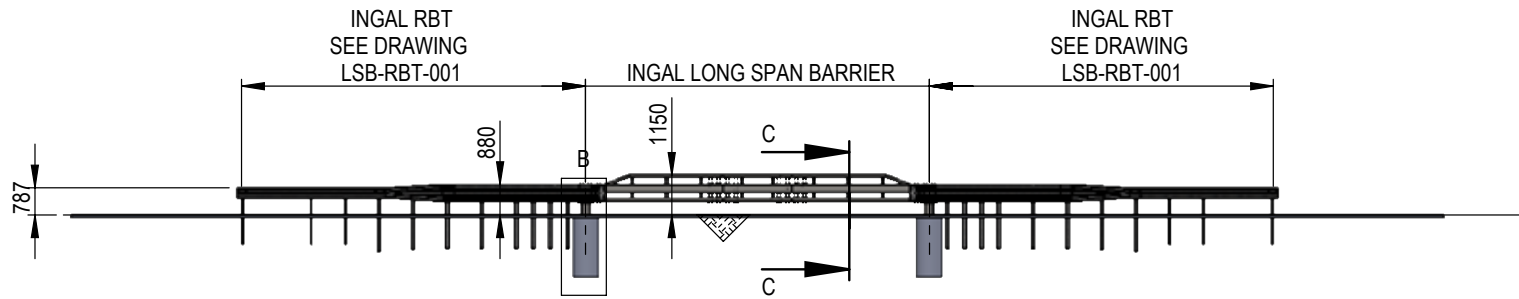
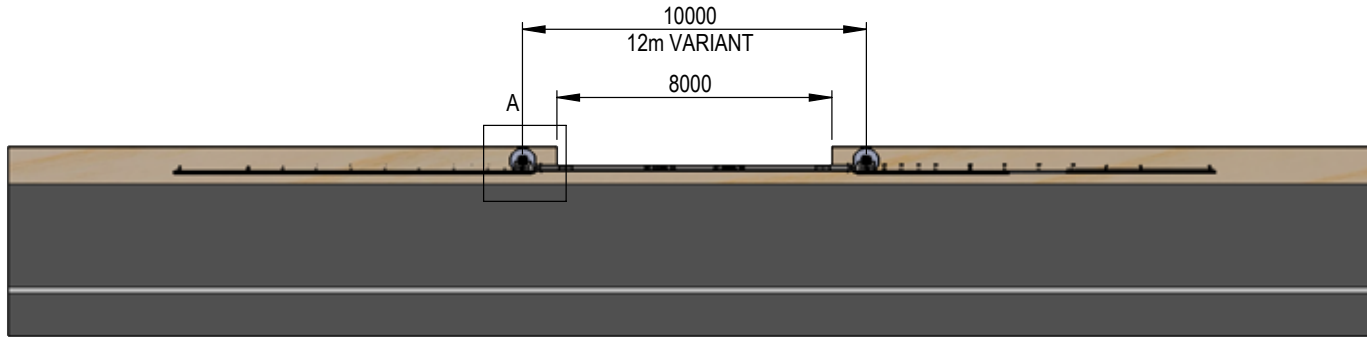

DETAIL A
SCALE 1 : 50

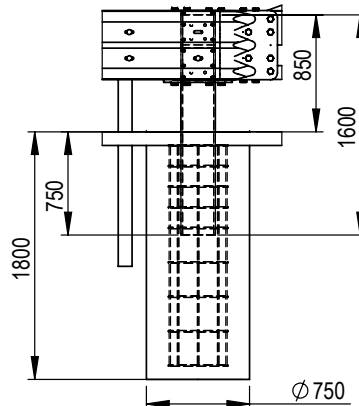

DETAIL B
SCALE 1 : 50

CULVERT EDGE ALIGNED WITH THE FRONT FACE OF THE INGAL LSB

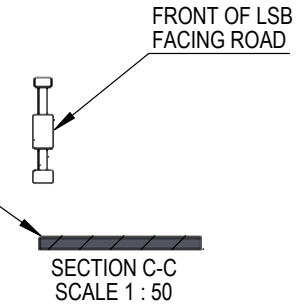

REV.	DATE	DESCRIPTION	DRAWN	CHECKED	APPROVED

DRAWING NUMBER	REFERENCE DRAWINGS

NAME	DATE
DRAWN KZ	31/10/2023
CHECKED LB	31/10/2023
APPROVED LB	31/10/2023
SCALE 1:200	SHEET: 1 of 1
ISSUE FOR	

INGAL CIVIL PRODUCTS
A valmont COMPANY

DRAWING AND CONTENTS ARE COPYRIGHT TO INGAL CIVIL PRODUCTS AND CAN ONLY BE USED WITH PRIOR WRITTEN CONSENT FROM INGAL CIVIL PRODUCTS.

57 AS AMOS ROAD
MUNGO, N.S.W 2566
PH +61 2 9697 3333
www.ingalcivil.com.au

PROJECT	TITLE
	INGAL LONG SPAN BARRIER - 10m LAYOUT

INGAL CIVIL PRODUCTS PART No.	-
DRAWING No.	LSB-STD-017
Rev.	0

FOLDER: F:\ENGINEERING\4. DRAWINGS IN PROGRESS\SOLIDWORKS MODEL IN PROGRESS\IGATOR\CURRENT\TY_ MODEL\CONCEPT 11 SIM MODEL

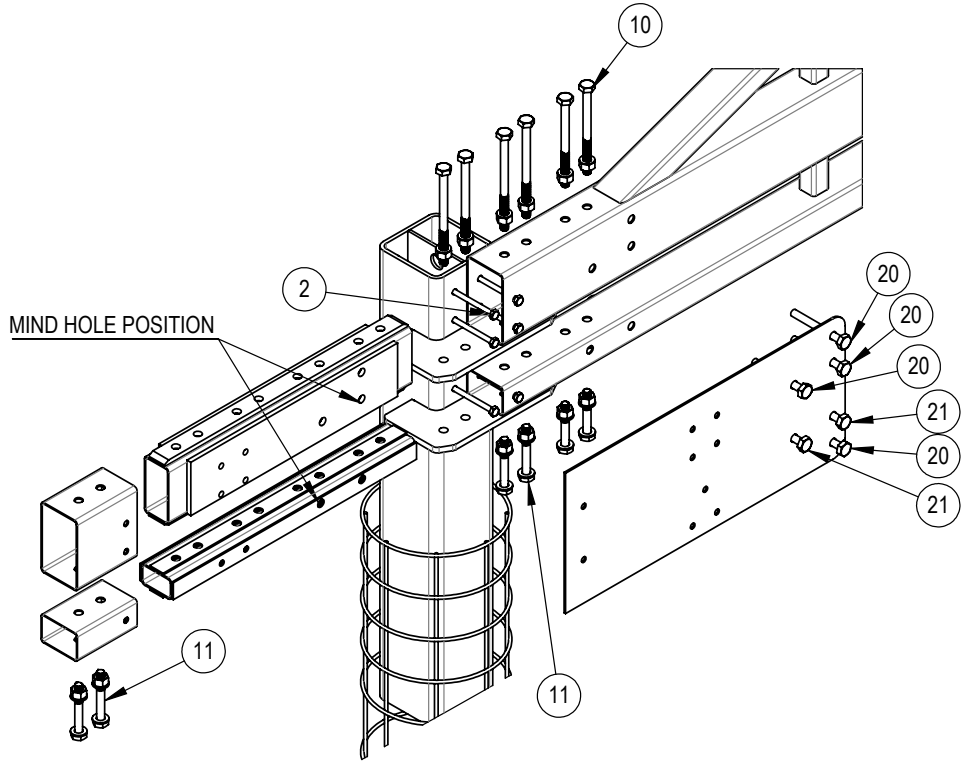
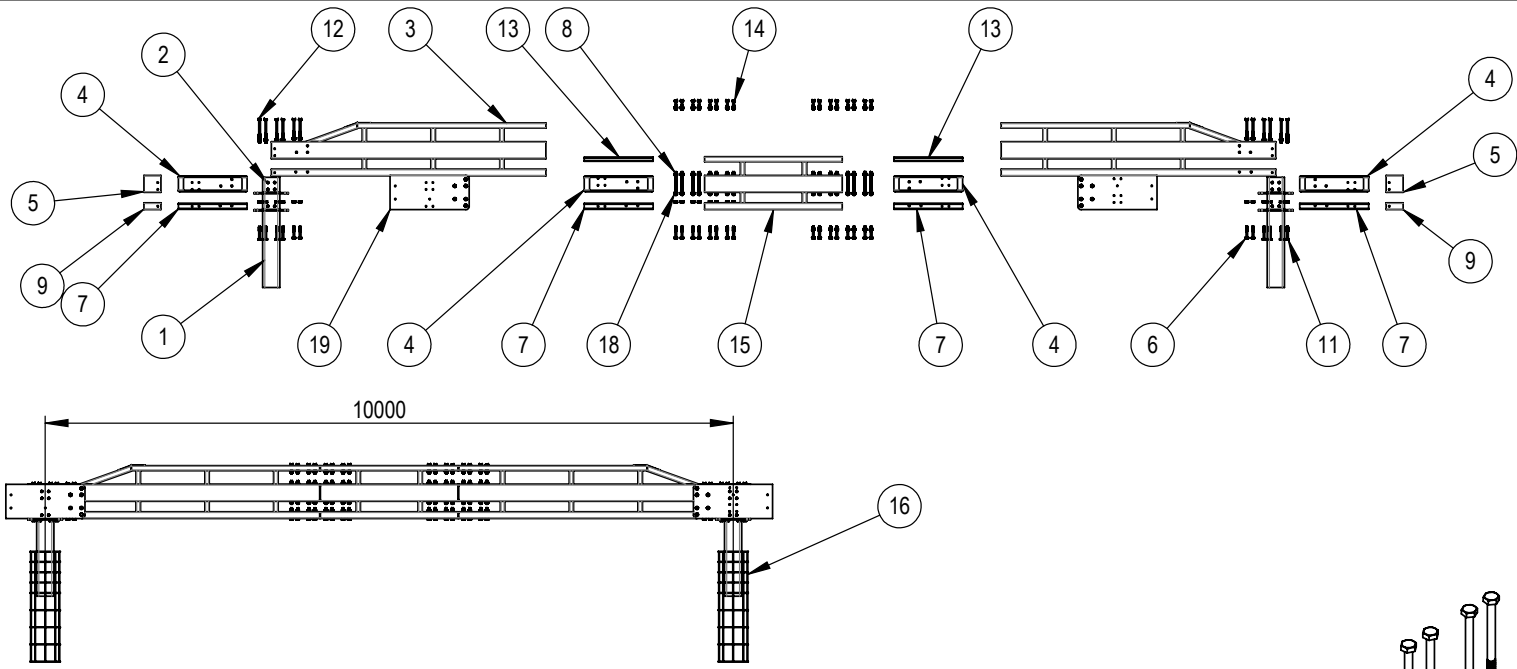

ID	DESCRIPTION	PART NO.	QTY.
1	ANCHOR POST ASSEMBLY	10010668	2
2	M16 x 450 STRUCTURAL BOLT NUT WASHER SET - GRADE 8.8 TO AS1252 K0 CLASS	10010511	12
3	LEADING-TRAILING PANEL ASSEMBLY	10010669	2
4	MID BEAM JOINER	10010671	4
5	RHS - 250 x 150 x 5 - 245mm	10010648	2
6	M24 x 150 STRUCTURAL BOLT - GRADE 8.8 TO AS1252 K0 CLASS	10010513	20
7	LOWER BEAM JOINER	10010672	4
8	M24 x 330 THREADED ROD - GRADE 8.8 TO AS1252 K0 CLASS	10010568	16
9	RHS - 150 x 100 x 4 - 245mm	10010647	2
10	M24 x 300 STRUCTURAL BOLT NUT WASHER SET - GRADE 8.8 TO AS1252 K0 CLASS	10010514	4
11	M24 x 170 STRUCTURAL BOLT - GRADE 8.8 TO AS1252 K0 CLASS	10010567	8
12	M24 x 330 STRUCTURAL BOLT NUT WASHER SET - GRADE 8.8 TO AS1252 K0 CLASS	10010569	8
13	UPPER BEAM JOINER	10010673	2
14	M24 x 120 STRUCTURAL BOLT NUT WASHER SET - GRADE 8.8 TO AS1252 K0 CLASS	10010566	16
15	INTERMEDIATE PANEL ASSEMBLY - 2M	10010676	1
16	CONCRETE FOOTING REO BAR	10010554	2
17	NORD LOCK WASHER M24 - NL24SP GRADE 8.8	10010570	88
18	M24 STRUCTURAL NUT - GRADE 8.8 TO AS1252 K0 CLASS	10002169	60
19	INGAL LONG SPAN BARRIER CONNECTION PLATE	10010684	2
20	M24 x 200 STRUCTURAL BOLT NUT WASHER SET - GRADE 8.8 TO AS1252	10002171	8
21	M24 x 50mm BOLT NUT SET - GRADE 8.8	10009685	4

REV.	DATE	DESCRIPTION	DRAWN	CHECKED	APPROVED

DRAWING NUMBER	REFERENCE DRAWINGS

	NAME	DATE
DRAWN	KZ	22-06-2023
CHECKED	LB	31/10/2023
APPROVED	LB	31/10/2023
SCALE	1:100	SHEET: 1 of 1
ISSUE FOR		

INGAL CIVIL PRODUCTS
A valmont COMPANY

DRAWING AND CONTENTS ARE COPYRIGHT TO
INGAL CIVIL PRODUCTS AND CAN ONLY BE USED
WITH PRIOR WRITTEN CONSENT FROM INGAL CIVIL
PRODUCTS

ST-45 AMES ROAD
MINDO, N.S.W 2566
PH: +61 2 9697 3333
www.ingalcivil.com.au

PROJECT	
TITLE	INGAL LONG SPAN BARRIER COMPONENTS - 10M

INGAL CIVIL PRODUCTS PART No.	10010680
DRAWING No.	LSB-STD-004
Rev.	0

FOLDER: F:\ENGINEERING\4. DRAWINGS IN PROGRESS\SOLIDWORKS MODEL IN PROGRESS\GATOR\CURRENT\1_MODEL\CONCEPT 11 SIM MODEL

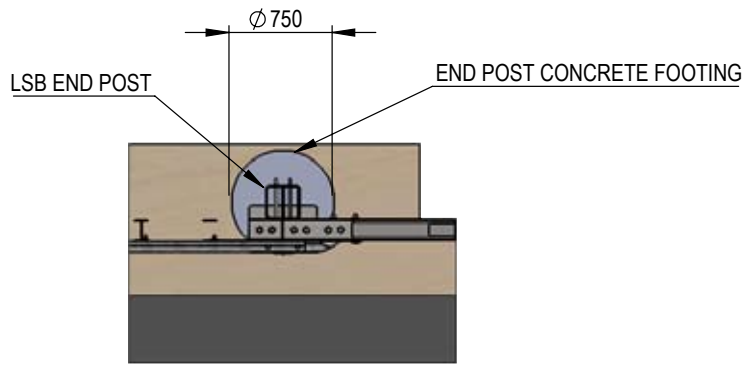
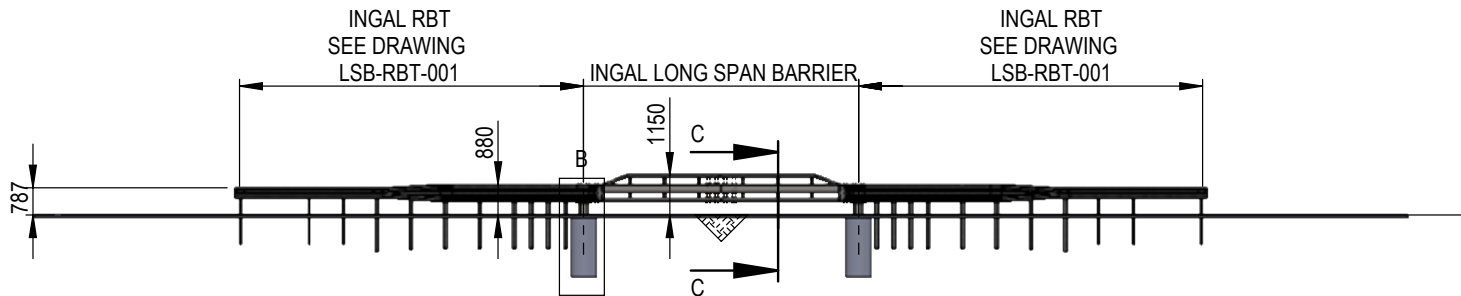
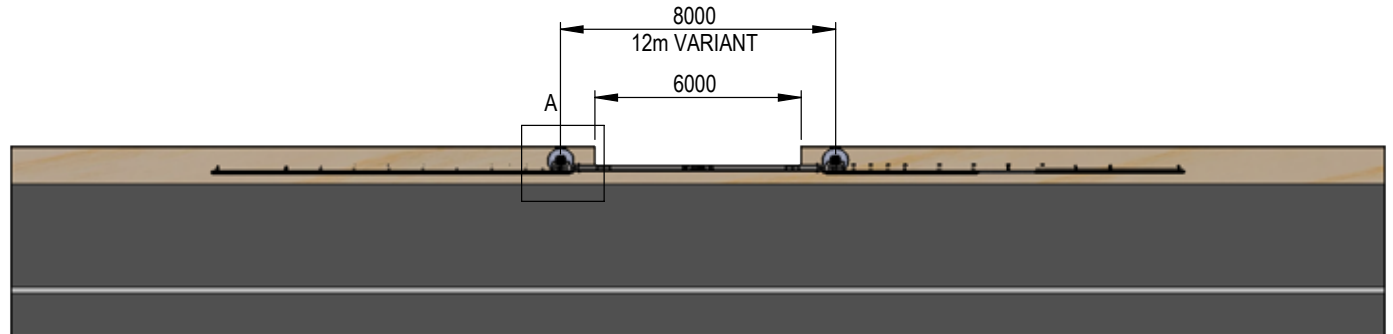

DETAIL A
SCALE 1 : 50

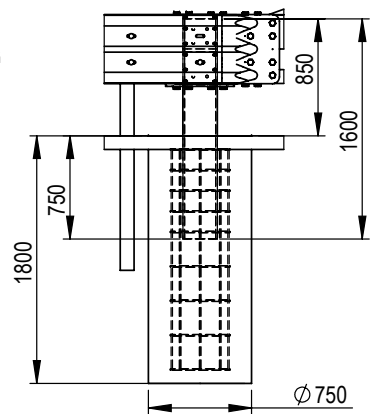

DETAIL B
SCALE 1 : 50

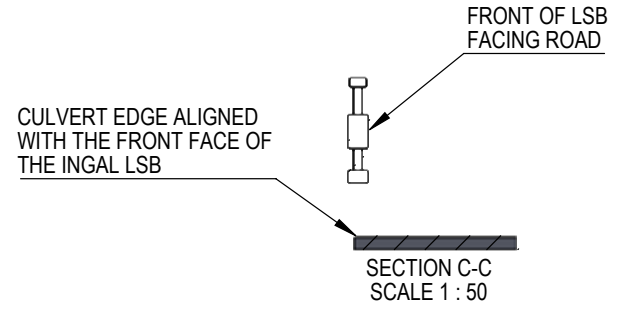

SECTION C-C
SCALE 1 : 50

REVISIONS							PROJECT	INGAL CIVIL PRODUCTS PART No.	
								-	
							TITLE	INGAL LONG SPAN BARRIER - 8m LAYOUT	
							DRAWING No.	LSB-STD-018	
REV.	DATE	DESCRIPTION	DRAWN	CHECKED	APPROVED	DRAWING NUMBER REFERENCE DRAWINGS	NAME DATE DRAWN CHECKED APPROVED SCALE SHEET: 1 of 1 ISSUE FOR	57 AS AMOS ROAD MUNGO, N.S.W 2566 PH +61 2 9697 3333 www.ingalcivil.com.au	Rev: 0

FOLDER: F:\ENGINEERING\4. DRAWINGS IN PROGRESS\SOLIDWORKS MODEL IN PROGRESS\IGATOR\CURRENT\1_MODEL\CONCEPT 11 SIM MODEL

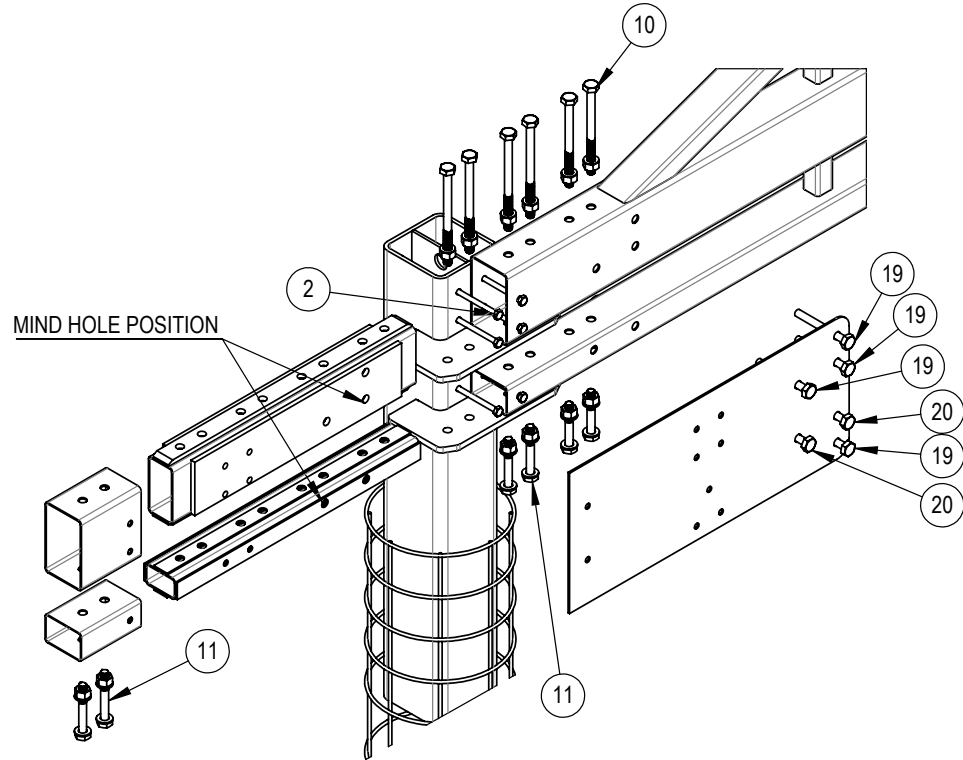
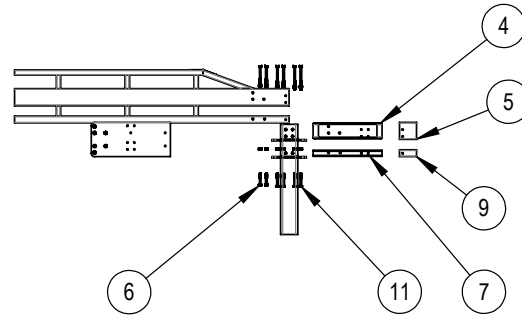
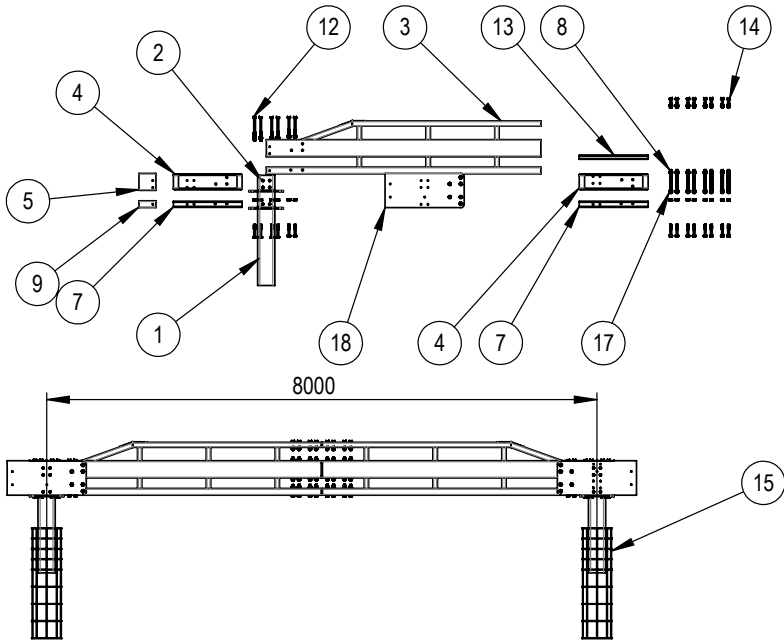

ID	DESCRIPTION	PART NO.	QTY.
1	ANCHOR POST ASSEMBLY	10010668	2
2	M16 x 450 STRUCTURAL BOLT NUT WASHER SET - GRADE 8.8 TO AS1252 K0 CLASS	10010511	12
3	LEADING-TRAILING PANEL ASSEMBLY	10010669	2
4	MID BEAM JOINER	10010671	3
5	RHS - 250 x 150 x 5 - 245mm	10010648	2
6	M24 x 150 STRUCTURAL BOLT - GRADE 8.8 TO AS1252 K0 CLASS	10010513	12
7	LOWER BEAM JOINER	10010672	3
8	M24 x 330 THREADED ROD - GRADE 8.8 TO AS1252 K0 CLASS	10010568	8
9	RHS - 150 x 100 x 4 - 245mm	10010647	2
10	M24 x 300 STRUCTURAL BOLT NUT WASHER SET - GRADE 8.8 TO AS1252 K0 CLASS	10010514	4
11	M24 x 170 STRUCTURAL BOLT - GRADE 8.8 TO AS1252 K0 CLASS	10010567	8
12	M24 x 330 STRUCTURAL BOLT NUT WASHER SET - GRADE 8.8 TO AS1252 K0 CLASS	10010569	8
13	UPPER BEAM JOINER	10010673	1
14	M24 x 120 STRUCTURAL BOLT NUT WASHER SET - GRADE 8.8 TO AS1252 K0 CLASS	10010566	8
15	CONCRETE FOOTING REO BAR	10010554	2
16	NORD LOCK WASHER M24 - NL24SP GRADE 8.8	10010570	56
17	M24 STRUCTURAL NUT - GRADE 8.8 TO AS1252 K0 CLASS	10002169	36
18	INGAL LONG SPAN BARRIER CONNECTION PLATE	10010684	2
19	M24 x 200 STRUCTURAL BOLT NUT WASHER SET - GRADE 8.8 TO AS1252	10002171	8
20	M24 x 50mm BOLT NUT SET - GRADE 8.8	10009685	4

REV.	DATE	DESCRIPTION	DRAWN	CHECKED	APPROVED

REV.	DATE	DESCRIPTION	DRAWN	CHECKED	APPROVED

NAME	DATE	PROJECT
DRAWN: KZ	22-06-2023	INGAL CIVIL PRODUCTS PART No. 10010681
CHECKED: LB	31/10/2023	DRAWING No. LSB-STD-005
APPROVED: LB	31/10/2023	Rev: 0
SCALE: 1:100	SHEET: 1 of 1	TITLE: INGAL LONG SPAN BARRIER COMPONENTS - 8M
ISSUE FOR:		

REFERENCE	REFERENCE DRAWINGS



DRAWING AND CONTENTS ARE COPYRIGHT TO INGAL CIVIL PRODUCTS AND CAN ONLY BE USED WITH PRIOR WRITTEN CONSENT FROM INGAL CIVIL PRODUCTS.

ST-45 AMES ROAD
MINDO, N.S.W 2566
PH: +61 2 9697 3333
www.ingalcivil.com.au

FOLDER: F:\ENGINEERING\4. DRAWINGS IN PROGRESS\SOLIDWORKS MODEL IN PROGRESS\GATOR\CURRENT\1_MODEL\CONCEPT 11 SIM MODEL

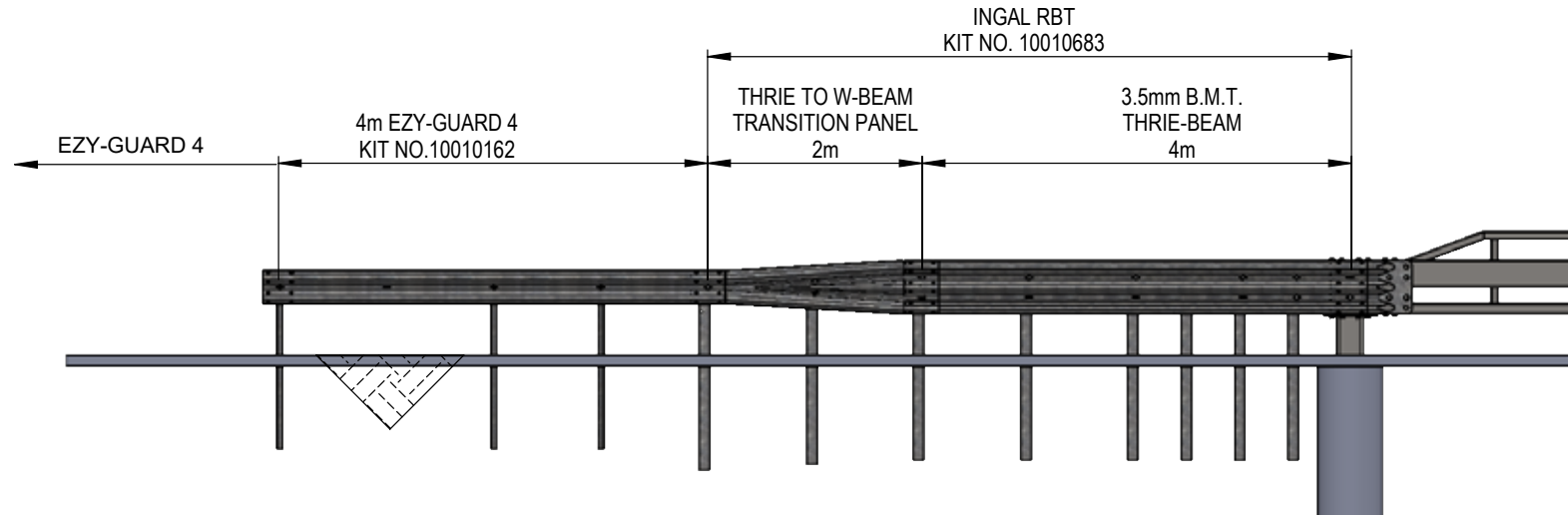
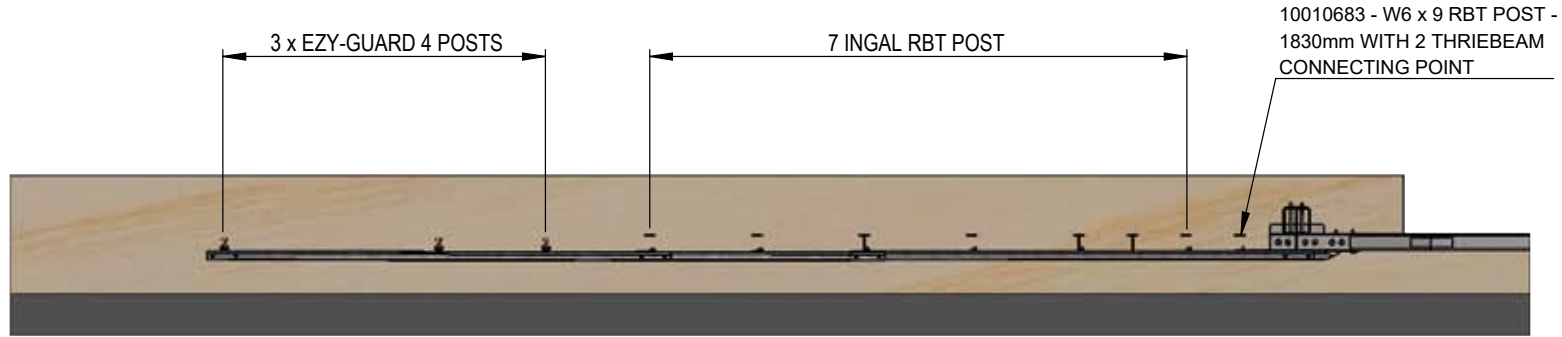

NOTE:
1. TO BE READ IN CONJUNCTION WITH
LSB-RBT-001 AND LSB-RBT-002

REVISIONS	REV.	DATE	DESCRIPTION	DRAWN	CHECKED	APPROVED	<table border="1"> <tr> <td>DRAWING NUMBER</td> <td>REFERENCE DRAWINGS</td> </tr> </table>	DRAWING NUMBER	REFERENCE DRAWINGS	<table border="1"> <tr> <td>NAME</td> <td>DATE</td> </tr> <tr> <td>DRAWN KZ</td> <td>31/10/2023</td> </tr> <tr> <td>CHECKED LB</td> <td>31/10/2023</td> </tr> <tr> <td>APPROVED LB</td> <td>31/10/2023</td> </tr> <tr> <td>SCALE 1:64</td> <td>SHEET: 1 of 1</td> </tr> <tr> <td>ISSUE FOR</td> <td></td> </tr> </table>	NAME	DATE	DRAWN KZ	31/10/2023	CHECKED LB	31/10/2023	APPROVED LB	31/10/2023	SCALE 1:64	SHEET: 1 of 1	ISSUE FOR		<p>INGAL CIVIL PRODUCTS A valmont COMPANY</p> <p>DRAWING AND CONTENTS ARE COPYRIGHT TO INGAL CIVIL PRODUCTS AND CAN ONLY BE USED WITH PRIOR WRITTEN CONSENT FROM INGAL CIVIL PRODUCTS</p> <p>57-55 AMES ROAD MUNTO, N.S.W 2566</p> <p>PH: +61 2 9697 3333 www.ingalcivil.com.au</p>	PROJECT TITLE INGAL LONG SPAN BARRIER - EZY-GUARD 4 CONNECTION	INGAL CIVIL PRODUCTS PART No. - DRAWING No. LSB-STD-012
	DRAWING NUMBER	REFERENCE DRAWINGS																							
	NAME	DATE																							
	DRAWN KZ	31/10/2023																							
	CHECKED LB	31/10/2023																							
APPROVED LB	31/10/2023																								
SCALE 1:64	SHEET: 1 of 1																								
ISSUE FOR																									

FOLDER: C:\USERS\KZ717943\DESKTOP\KZ LOCAL FILE\CONCEPT 11 SM MODEL

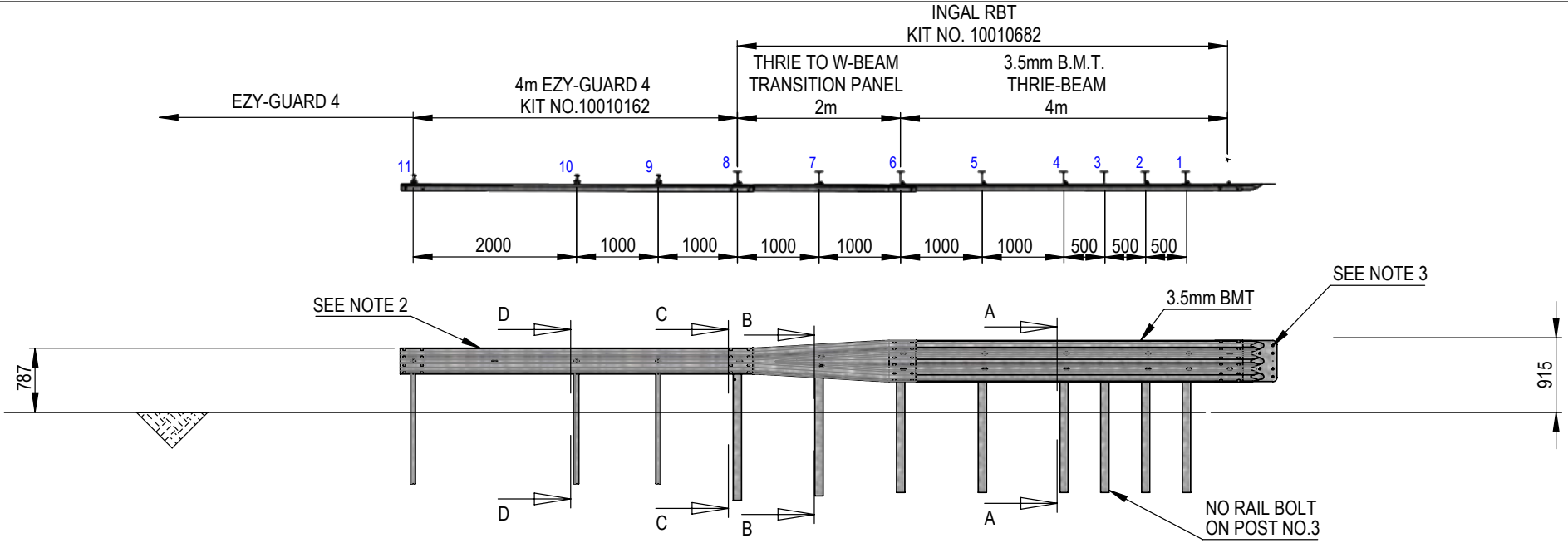

NOTE:

1. USED FOR CONNECTING IN GAL LSB
2. KIT NO. 10010162 IS NOT REQUIRED WHEN CONNECTING IN GAL LSB DIRECTLY TO ET-SS TERMINAL
3. REFER TO EZY-GUARD 4 MANUAL STANDARD EZY-GUARD 4 INSTALLATION
4. THE STRUCTURAL CONNECTOR IS FIXED TO THE IN GAL LSB VIA 6 x M20 STRUCTURAL BOLTS

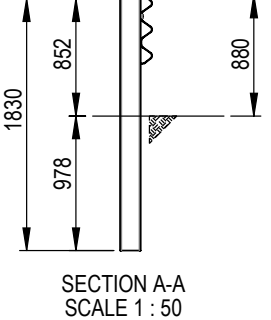
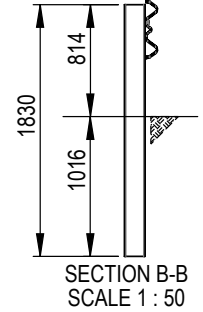
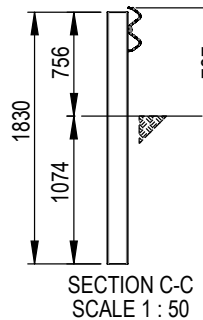
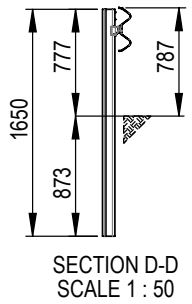

REVISIONS			REFERENCES			REFERENCES			INGAL CIVIL PRODUCTS			PROJECT		
1	4/05/2023	UPDATED FINISHING KIT NUMBER	KZ	LG	LG	DRAWING NUMBER	REFERENCE DRAWINGS	NAME	DATE		PART No.		10010682	
REV.	DATE	DESCRIPTION	DRAWN	CHECKED	APPROVED			DRAWN	06-11-2023		DRAWING No.		LSB-RBT-001	
								CHECKED	06-11-2023		TITLE			INGAL RBT TO EZY-GUARD 4 FOR IN GAL LONG SPAN BARRIER
								APPROVED	06-11-2023		DRAWING AND CONTENTS ARE COPYRIGHT TO IN GAL CIVIL PRODUCTS AND CAN ONLY BE USED WITH PRIOR WRITTEN CONSENT FROM IN GAL CIVIL PRODUCTS			Rev: 0
								SCALE	1:70	SHEET: 1 of 3	PROJECT			
								ISSUE FOR			77-45 ARDS ROAD MINTO, N.S.W 2566			
											PH: +61 2 9827 3333 www.ingalcivil.com.au			

FOLDER: C:\USERS\KZ71794\ONE\DRIVE - VALMONT INDUSTRIES, INC.\SOLIDWORKS MODEL IN PROGRESS\GATOR\CURRENT\1 MODEL\CONCEPT 11 SIM MODEL

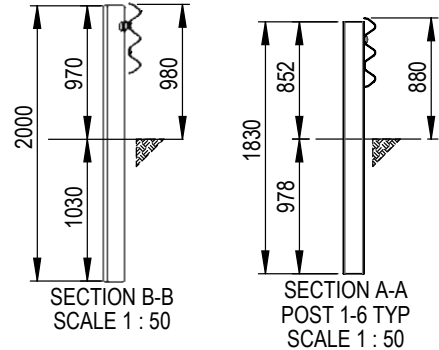
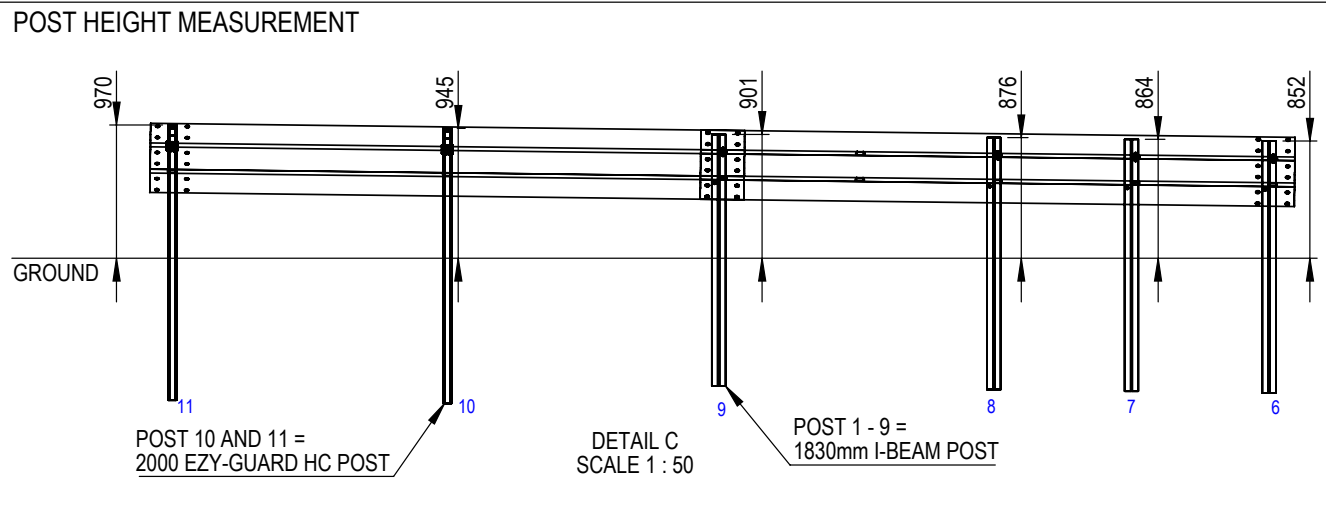
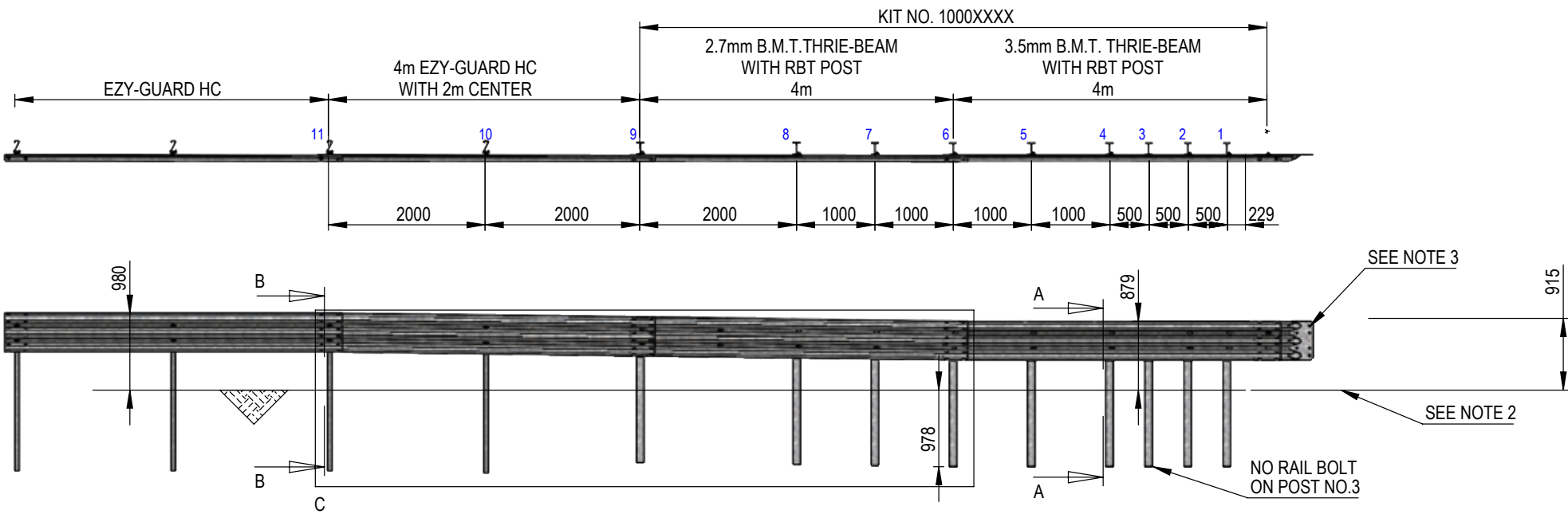

- NOTE:
1. USED FOR CONNECTING INGAL LSB
 2. REFER TO EZY-GUARD HC MANUAL STANDARD EZY-GUARD HC INSTALLATION
 3. CONCRETE BARRIER TO BE CONSTRUCTED IN ACCORDANCE WITH SBTA 21-005 SHEET 5 AND 7
 4. THE STRUCTURAL CONNECTOR IS FIXED TO THE CONCRETE VIA FIVE M20 x 200 HOBSON EAW-GD CLAWBOLT. INSTALLATION SHALL BE IN ACCORDANCE WITH THE MANUFACTURER'S INSTRUCTION

REVISIONS	REV.	DATE	DESCRIPTION	DRAWN	CHECKED	APPROVED	REFERENCES DRAWING NUMBER REFERENCE DRAWINGS SCALE 1:70 SHEET: 1 of 4 ISSUE FOR	NAME DATE DRAWN KZ 13-11-2023 CHECKED LB 13-11-2023 APPROVED KZ 13-11-2023 SCALE 1:70 SHEET: 1 of 4 ISSUE FOR	INGAL CIVIL PRODUCTS A valmont COMPANY DRAWING AND CONTENTS ARE COPYRIGHT TO INGAL CIVIL PRODUCTS AND CAN ONLY BE USED WITH PRIOR WRITTEN CONSENT FROM INGAL CIVIL PRODUCTS 57-65 AIRDS ROAD Ph: +61 2 9827 3333 MINTO, N.S.W 2566 www.ingalcivil.com.au	PROJECT INGAL RBT TO EZY-GUARD HC FOR INGAL LONG SPAN BARRIER	INGAL CIVIL PRODUCTS PART No. 10010797	
	DRAWING No. LSB-RBT-011											
	Rev: 0											
	FOLDER: F:\ENGINEERING\4 - DRAWINGS IN PROGRESS\GATOR\CURRENT\1 MODEL\CONCEPT 11 SIM MODEL											

ID	DESCRIPTION	PART NO.	QTY.
1	THRIEBEAM TERMINAL CONNECTOR FOR LSB 2.7mm	10010552	1
2	THRIEBEAM (3.5) 4000mm NLL BRIDGE APPROACH	10000854	1
3	W6 x 9 RBT POST FOR INGAL LSB - 1830mm	10010287	8
4	M16 OVERSIZE NUT	10001239	46
5	M16 X 50mm POST BOLT GRADE 4.6	10001233	10
6	M16 X 32 SPLICE BOLT GRADE 8.8	10001248	36
7	THRIEBEAM (2.7) 4000mm NLL 1000mm CENTRES	10000849	1
8	W6 x 9 RBT POST - 1830mm WITH 2 THRIEBEAM CONNECTING POINT	10010683	1

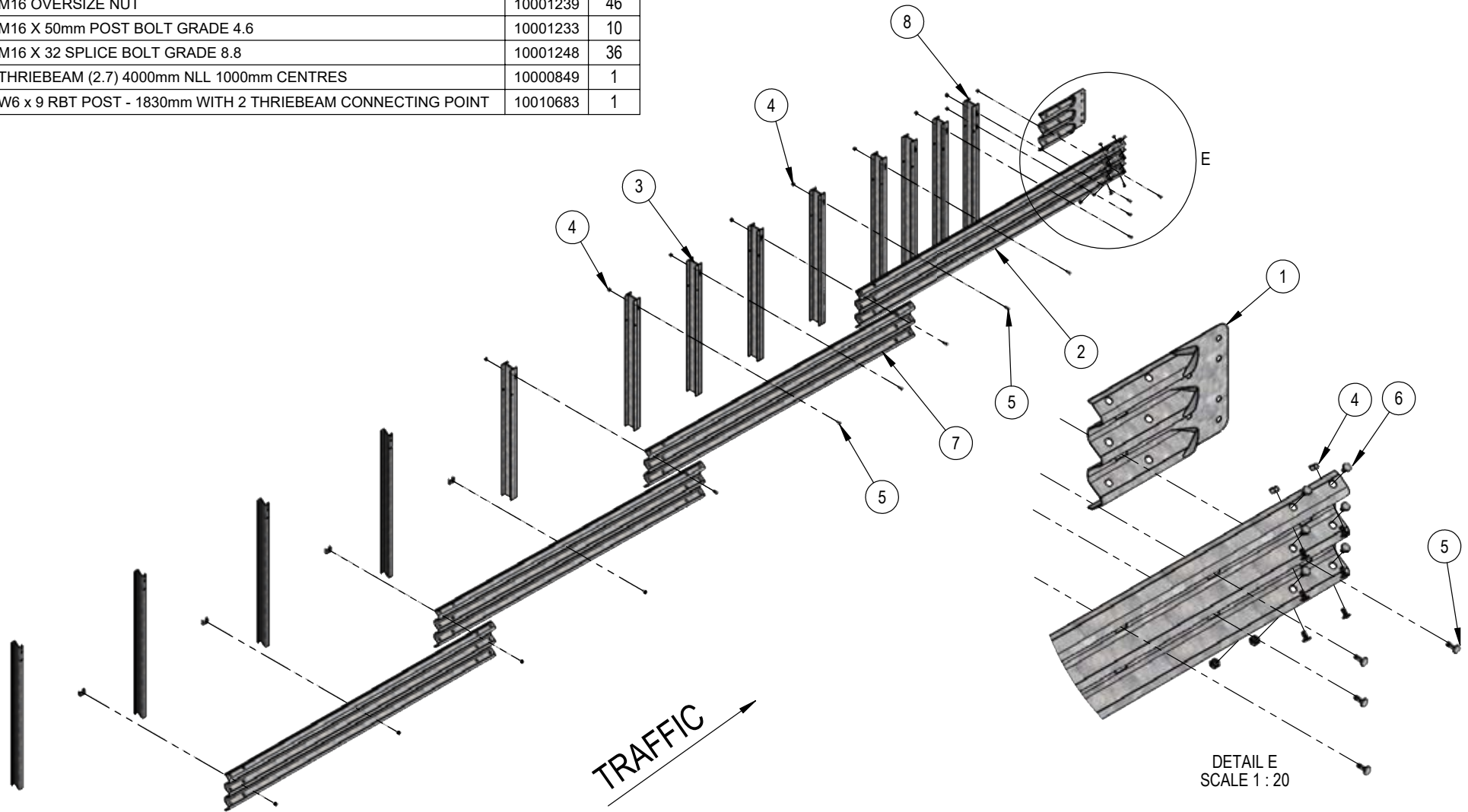

REVISIONS	REFERENCES	DRAWN	NAME	DATE
		KZ		13-11-2023
		LB		13-11-2023
		KZ		13-11-2023
	DRAWING NUMBER	REFERENCE DRAWINGS	SCALE	1:60
			ISSUE FOR	SHEET: 2 of 4

INGAL CIVIL PRODUCTS
A valmont COMPANY

DRAWING AND CONTENTS ARE COPYRIGHT TO INGAL CIVIL PRODUCTS AND CAN ONLY BE USED WITH PRIOR WRITTEN CONSENT FROM INGAL CIVIL PRODUCTS.

57-65 ABBE ROAD
MINTO, N.S.W 2564

PH: +61 2 9827 3333
WWW.INGALCIVIL.COM.AU

PROJECT	INGAL CIVIL PRODUCTS
TITLE	INGAL RBT TO EZY-GUARD HC FOR INGAL LONG SPAN BARRIER - EXPLODED VIEW

PART No.	10010797
DRAWING No.	LSB-RBT-012
Rev.	0

FOLDER: F:\ENGINEERING4. DRAWINGS IN PROGRESS\ SOLIDWORKS MODEL IN PROGRESS\GATOR\CURRENT11_MODEL\CONCEPT 11 SIM MODEL

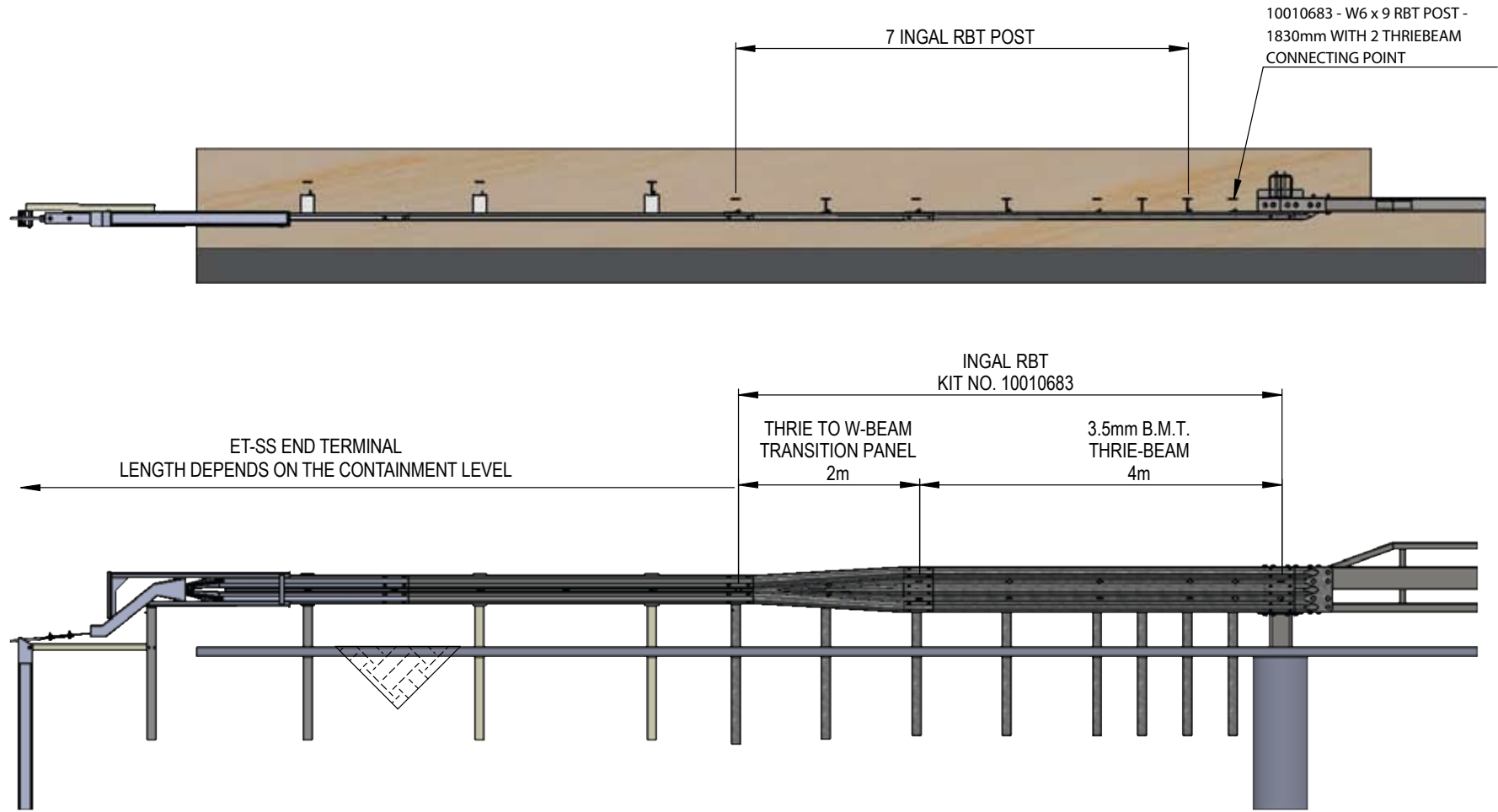

NOTE:

1. TO BE READ IN CONJUNCTION WITH LSB-RBT-001 AND LSB-RBT-002
2. ET-SS TERMINAL LENGTH:
 - TL2 = 7.9m
 - TL3 = 15.5m

REVISIONS	REV.	DATE	DESCRIPTION	DRAWN	CHECKED	APPROVED	REFERENCES				NAME	DATE	 <small>DRAWING AND CONTENTS ARE COPYRIGHT TO INGAL CIVIL PRODUCTS AND CAN ONLY BE USED WITH PRIOR WRITTEN CONSENT FROM INGAL CIVIL PRODUCTS</small>	PROJECT	INGAL CIVIL PRODUCTS PART No.			
								DRAWING NUMBER	REFERENCE DRAWINGS					TITLE	INGAL LONG SPAN BARRIER - ET-SS CONNECTION	DRAWING No.	LSB-STD-014	
																	Rev: 0	

FOLDER: E:\ENGINEERING\4. DRAWINGS IN PROGRESS\4. MODEL IN PROGRESS\GATOR\CURRENT\1. MODEL\CONCEPT 11 SIM MODEL\

FASTENERS

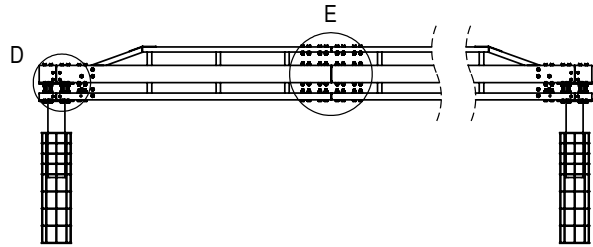

NOTE:

1. NORD LOCK WASHER TO BE USED ON THE BOLT WITH POTENTIAL CHANCE OF FALLING OUT FROM THE ASSEMBLY
2. M16 TORQUE SETTING 95NM
3. M24 TORQUE SETTING 100NM
4. M16 x 450mm LONG BOLTS ALSO NEEDS TO GO THROUGH THE CONNECTION PLATE, SEE DRAWING LSB-STD-023

FASTENERS AT MAIN POST

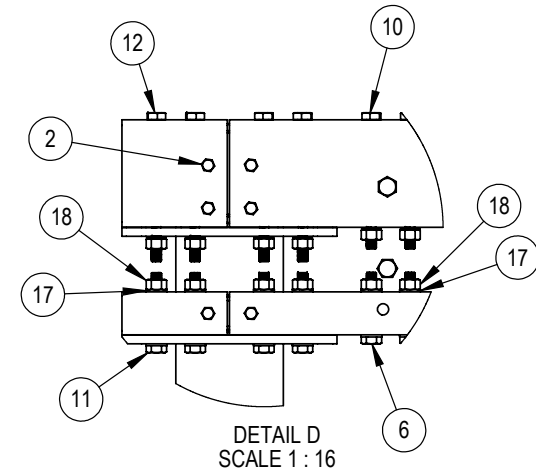

FASTENERS AT JOINERS

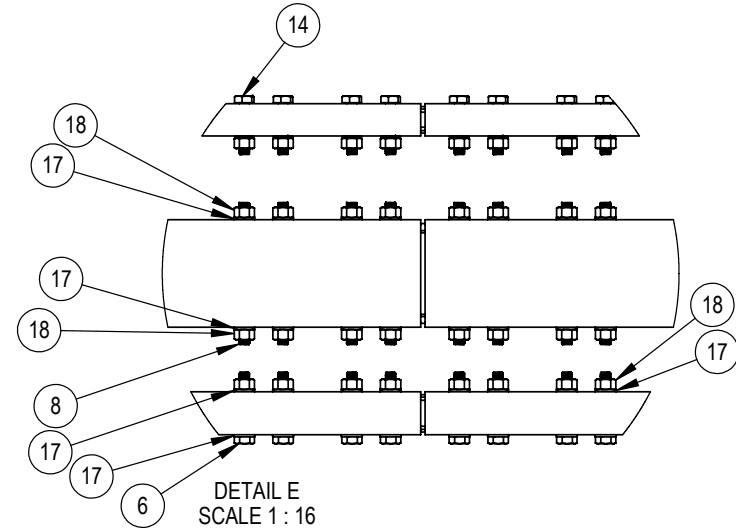

ID	DESCRIPTION	PART NO.	QTY.
1	Anchor Post Assembly	10010668	2
2	M16 x 450 Structural Bolt Nut Washer Set - Grade 8.8 to AS1252 K0 Class	10010511	12
3	Leading-Trailing Panel Assembly	10010669	2
4	Mid Beam Joiner	10010671	4
5	RHS - 250 x 150 x 5 - 245mm	10010648	2
6	M24 x 150 Structural Bolt - Grade 8.8 to AS1252 K0 Class	10010513	20
7	Lower Beam Joiner	10010672	4
8	M24 x 330 Threaded Rod - Grade 8.8 to AS1252 K0 Class	10010568	16
9	RHS - 150 x 100 x 4 - 245mm	10010647	2
10	M24 x 300 Structural Bolt Nut Washer Set - Grade 8.8 to AS1252 K0 Class	10010514	4
11	M24 x 170 Structural Bolt - Grade 8.8 to AS1252 K0 Class	10010567	8
12	M24 x 330 Structural Bolt Nut Washer Set - Grade 8.8 to AS1252 K0 Class	10010569	8
13	Upper Beam Joiner	10010673	2
14	M24 x 120 Structural Bolt Nut Washer Set - Grade 8.8 to AS1252 K0 Class	10010566	16
15	Intermediate Panel Assembly - 8m	10010670	1
16	Concrete Footing Reo Bar	10010554	2
17	Nord Lock Washer M24 - NL24sp Grade 8.8	10010570	88
18	M24 Structural Nut - Grade 8.8 to AS1252 K0 Class	10002169	60
19	INGAL LONG SPAN BARRIER CONNECTION PLATE	10010684	2
20	M24 x 200 Structural Bolt Nut Washer Set - Grade 8.8 to AS1252	10002171	8
21	M24 x 50mm Bolt Nut Set - Grade 8.8	10009685	4

REV.	DATE	DESCRIPTION	DRAWN	CHECKED	APPROVED	DRAWING NUMBER	REFERENCE DRAWINGS	NAME	DATE		PROJECT	INGAL CIVIL PRODUCTS PART No.
								DRAWN	KZ	22-06-2023		
								CHECKED	LB	31/10/2023		-
								APPROVED	LB	31/10/2023		
								SCALE	1:100	SHEET: 1 of 1	TITLE	INGAL LONG SPAN BARRIER COMPONENTS - 16M
								ISSUE FOR				DRAWING No.
												LSB-STD-022
												Rev. 0

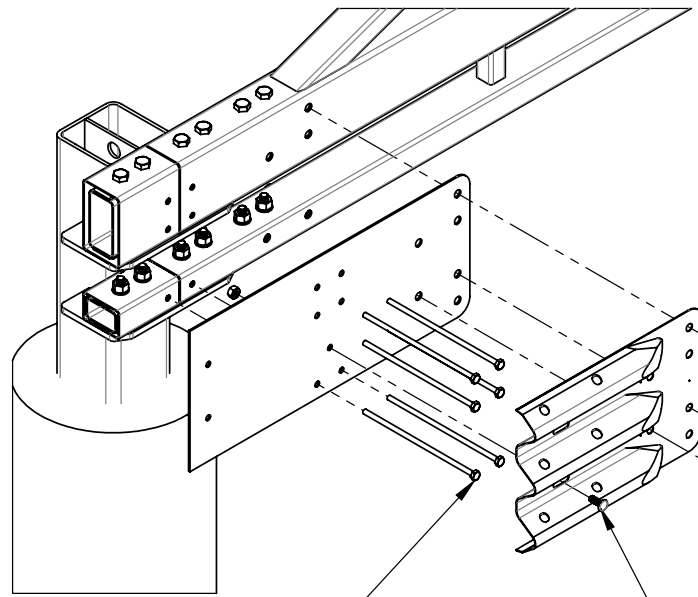

10010511 - M16 x 450
STRUCTURAL BOLT NUT
WASHER SET - GRADE 8.8

10002171 - M24 x 200 STRUCTURAL BOLT
NUT WASHER SET - GRADE 8.8

10009685 - M24 x 50mm HEX BOLT NUT SET - GRADE 8.8

10001233 - M16 X 50 POST BOLT GRADE 4.6

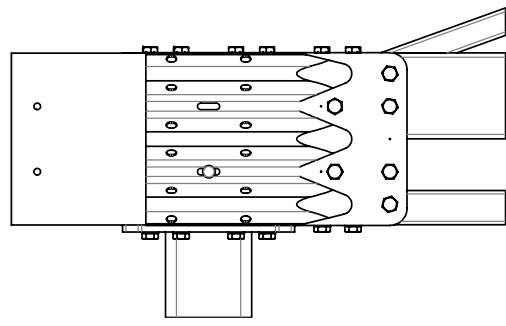

REV. DATE DESCRIPTION DRAWN CHECKED APPROVED	REFERENCES		DRAWN	KZ	31/10/2023		PROJECT	INGAL CIVIL PRODUCTS PART No.
	DRAWING NUMBER	REFERENCE DRAWINGS	CHECKED	LB	31/10/2023		TITLE	-
			APPROVED	LB	31/10/2023	<small>DRAWING AND CONTENTS ARE COPYRIGHT TO INGAL CIVIL PRODUCTS AND CAN ONLY BE USED WITH PRIOR WRITTEN CONSENT FROM INGAL CIVIL PRODUCTS</small>	TITLE	INGAL - LSB CONNECTION PLATE FITTING
			SCALE	1:20	SHEET: 1 of 1		DRAWING No.	LSB-STD-023
			ISSUE FOR			<small>57-65 ARDS ROAD MINTO, N.S.W. 2564</small>		Rev: 0

FOLDER: C:\USERS\KZ17943\DESK\TOP\KZ LOCAL FILE\CONCEPT 11 SIMI MODEL



INGAL

CIVIL PRODUCTS

A **valmont**  COMPANY

For more information

contact us on the web

www.ingalcivil.com.au

Head Office: Sydney

57-65 Airds Road, Minto, NSW 2566

Ph: +61 2 9827 3333

Fax: +61 2 9827 3300

Local call (within Australia):

1300 446 425

Email: sales@ingalcivil.com.au

Our Locations:

• Adelaide/NT • Brisbane

• Melbourne • Newcastle

• Perth • Sydney • Wagga

• Auckland • Christchurch