



**Valley Pro2
Control Panel
Advanced Features Manual
For
Software Version 9.02
0998944_D**

Valley Pro2 Control Panel

Table of Contents

About This Manual	7
Ancillary Equipment Warranty	7
System.....	9
System Screen.....	9
Constants.....	9
Constants Screens.....	9
Time	10
Date.....	10
Stop-In-Slot (SIS)	11
End-Gun Sequences.....	12
Position.....	14
Pressure Delay.....	18
Low Pressure Limit.....	19
Minimum Application	19
Voltage	20
Hours/Rev	20
Wide Boundary.....	21
Flowmeter.....	23
RTU ID (Remote Telemetry Unit Identity)	23
Daily Ops.....	24
Daily Operations Mode	24
Load Management Mode.....	24
Wind	28
AR/AS (Auto Reverse/Auto Stop).....	29
Percent Timer	30
Low Voltage.....	31
Dir Offset	32
Estimating the Direction Offset	32
Calculating Direction Offset	33
Engine/Pump.....	35
Com Port.....	36
Remote Control	36
Key Wait.....	37
Config Notice	38
Service Tool	40
PLC.....	40
Remote Control V2	42
GPS V1	42
None	42
Pres Cal.....	43
Pres Type.....	43
Backlight.....	43
Cruise Control	44
VRI-Zone.....	45
End Water Pressure Monitor	49
Watering Timer	49
Temperature	52
Rain.....	53
Data	55
A/D - Analog to Digital Voltages	55
Pulse	56
Modules	57
Flow/Wind/Temp	58
End Water Pressure	58
Count.....	58
Tire Pressure.....	59
Reset.....	59
Review.....	60
Cycle	63
Transmit.....	63
Language	63
Hours.....	65

Table of Contents

Options	67
Options Screen	67
Auxiliary Relays	67
Using AUX1 or AUX2	67
Remote Lockout	68
Notice Callout	69
Event Notification	70
Shutdown Events	70
Warning Events	70
Status Change Events	70
Events	71
Shutdown Events	71
Warning 1 Events	71
Warning 2 Events	71
Status Change 1 Events	72
Status Change 2 Events	72
Cruise Control	73
AR/AS (Auto Reverse/Auto Stop)	74
Auto Restart	74
Pressure Restart	75
Power Restart	75
End Gun	76
For/Rev Position	77
START\$ Program	78
STOP\$ Program	80
CYCLE\$ Program	81
Module	85
VRI	86
VRI Speed Control	86
VRI-S ON/OFF	86
View Prescription	88
Add Sector	88
Position Values	88
VRI-Zone Control	89
VRI-Zone Speed Control Feature	90
View Prescription	91
Add Sector	92
Position Values	92
Adjustments	92
VRI-Zone Control	93
Overview	93
VRI Tower Box	93
Water Filter	93
Sprinkler Valve	93
Data Port	94
Stand Pipe Option	94
Diagnostics	95
Diagnostics Screen	95
System Faults	95
Viewing System Faults	96
Status Screen Diagnostics	96
Clearing an Error Code	96
Error Codes	97
Error Logs	98
Viewing an Error Log	98
Resetting an Error Log to Zero	98

Table of Contents

Step Programming	99
Program Screen.....	99
Step Programs.....	99
Step Program Functions.....	99
Programming Conditions.....	99
Available Commands.....	99
Available Options.....	99
Stored Program.....	99
Other Programming Conditions.....	100
Analog	100
Module.....	100
Pulse.....	101
Count.....	101
Wind	101
Temperature.....	101
Rain	101
Run Program Command	102
Start at a Step	102
Example Step Program Design Form.....	103
Using Create New	104
Using Review Current.....	105
Using Review Stored.....	106
Using Edit.....	106
Using Erase.....	107
Step Program Examples	109
Designing Step Programs.....	109
Example Step Program and Design Form	109
Example 1. Program by Time and Position	110
Example 2. Program by Day and Time.....	113
Example 3. Program by Time and Position with SIS On	116
Example 4. Program by Position and Delay	119
Example 5. Program by Position, Delay, and Direction.....	123
Example 6. Program by Pressure.....	127
Example 7. Program by Position, Delay, and Module	129
Example 8. Program with Percent-of-Percent Timer or Percent-of-Depth	134
Example 9. Program with Enable/Disable End Guns	136
Example 10. Program with Enable/Disable Cruise Control	138
Example 11. Program with VRI ON/OFF	140
Example 12. Program for a Logging Event.....	142
Example 13. Using the Run Program Command	144
Repeating Irrigation Cycles.....	147
Example 1. Continuous Auto REVERSE Cycles.....	147
Example 2. Continuous Wet Area Water OFF Cycles.....	150
Example 3. Using Run Program Command	152
Scheduled Irrigation Cycles	157
Example 1. Time Delay with Run Program Command.....	157
START\$ Program Examples.....	164
Example 1. Delayed Start.....	164
Example 2. Immediate Start	165
STOP\$ Program Example	166
Example 1. Immediate Stop	166
CYCLE\$ Program Examples - Repeating Cycles	167
Example 1. Using CYCLE\$ Program.....	167
Executing CYCLE\$.....	168
Option 1 - Execute CYCLE\$ Immediately	168
Option 2 - Execute CYCLE\$ By Time	169

Table of Contents

Daily OPS Examples.....	170
Scheduled Irrigation Hours.....	170
Example 1. Seven Days a Week	170
Example 2. Selected Days with Stop before Start	171
Example 3. Selected Days with Start before Stop	172
Scheduled Irrigation Cycles	173
Example 4. Daily OPS Cycle - Interval in Days	173
Setup Cycle Interval.....	173
Write CYCLE\$ Program.....	174
Sector Programming.....	175
Program Screen.....	175
Sector Programs.....	175
Step Program Functions.....	175
Available Options.....	175
Available Commands.....	175
Using Run Stored.....	176
Sample Sector Program Design Form	177
Using Create New	178
Using Review Current	179
Using Review (Edit) Stored	180
Using Erase.....	180
Sector Program Examples.....	181
Designing Sector Programs	181
Example Sector Program and Design Form	181
Using the STOP Command.....	182
Using the Depth and Percent Commands.....	184
Using the End Gun and VRI Enable/Disable Commands.....	186
Using the Percent-of-Percent or Percent-of-Depth Command	189
Appendix: Programming Design Forms.....	191
Design Forms.....	191

About This Manual

Information contained in this manual applies to all Valley Pro2 Control Panels with software version 9.02. Sections related to safety, pivot hardware, maintenance, towing, troubleshooting and winterization are covered in the appropriate Valley Pivot Owners Manual.

You, as the owner/operator, should familiarize yourself with the capabilities of the system in order to obtain optimum system performance. It should be remembered that the sprinkler will perform according to your knowledge of the equipment, soil and water relationships and equipment application concepts.

Specifications, descriptions and illustrative material contained herein were as accurate as known at the time this publication was approved for printing.

Valmont Industries Inc., reserves the right to change specification or design without incurring obligation. Specifications are applicable to machines sold in the United States and may vary outside the United States.

Additional information is contained within the Valley Pro2 Control Panel Owner's Manual, Part Number 0998943 (English).

Ancillary Equipment Warranty

The owner is responsible for warranty registration of all ancillary equipment such as engines, pumps and generators with its respective manufacturer.

Introduction

System Screen

The user can change settings or view information from the System screen at anytime. See Figure 9-1.

Press  to display the System screen.

0 EXIT	3 RESET	6 TRANSMIT
1 CONSTANTS	4 REVIEW	7 LANGUAGE
2 DATA	5 CYCLE	8 HOURS
PRESS NUMBER >		

Figure 9-1 SYSTEM Screen

Constants

Constants are the constant values that are unique to each individual irrigation machine when the machine and control panel are first installed. These values should be recorded on the Systems Constants Record form located in the Control Panel Setup section of the owner's manual (part number 0998943). The constants values are on five separate screens. See Figure 9-2.

Constants Screens

Constants Screen 1		Constants Screen 2	
TIME	Set time of day in 24 hour format.	MIN APP	Set minimum application rate at 100%.
DATE	Set current date.	HRS/REV	Set time per revolution at 100%.
SIS	Review and edit stop-in-slot settings.	VOLTAGE	Set current voltage.
END-GUN	Set end gun on/off positions.	WIDE BND	Set second end gun on/off positions.
POSITION	Set position of machine in field.	FLOWMETER	Set flow meter pulse ratio.
PRES DLY	Set start up pressure time delay.	RTU ID	Set communication unit ID number.
LOW PRES	Set the low pressure limit.	DAILY OPS	Set daily operations parameters.
Constants Screen 3		Constants Screen 4	
WIND	Set wind high limit and on/off.	PRES CAL	Calibrate control panel with pressure transducer. Sets current to 0 tare.
AR/AS	Set auto reverse/auto stop on/off.	PRES TYPE	Set pressure sensor type.
PERCENT TIMER	Set percent timer cycle in seconds.	BACKLIGHT	Set backlight delay in minutes.
LOW VOLTAGE	Set low voltage shut down limit.	CRUISE CTL	Set cruise control.
DIR OFFSET	Set pivot direction offset in degrees.	VRI-ZONE	Set VRI-Zone control.
ENGINE/PUMP	Set engine or pump control.	TIRE PRES	Set tire pressure monitor sensor.
COM PORT	Set communications COM port/ baud rate or protocol.	END PRES	Set end water pressure monitor sensor.
Constants Screen 5			
WATERING TIMER	Set watering timer on/off and percent overwater shutdown.		
TEMPERATURE	Set low temperature limit and shutdown.		
RAIN	Set rainfall limit and shutdown.		



Figure 9-2 Constants Screens

System

Constants

Time





To set the time of day, follow the steps below.

1. Press , ,  to display the Time screen. See Figure 10-1.

NOTE: The value shown in parenthesis indicates the current value being used by the control panel.

2. Enter the time of day in a 24 hour format (HH:MM:SS). See Figure 10-1.



For example: If the time of day is 1:45 PM, the time of day is entered as 13:45.

- Press , , ,  for 1:45 PM. Seconds can be entered but are not necessary.

3. Press  to retain 1:45 PM as the time of day.







Date

To set the date, follow the steps below.

1. Press , ,  to display the Date screen. See Figure 10-2.

NOTE: The value shown in parenthesis indicates the current value being used by the control panel.

2. Enter the date.
 - When the unit of measure is set to inch, the date is entered in a month/day/year format.
 - When the unit of measure is set to metric, the date is entered in a day/month/year format.
 - For example: If the unit of measure is inch and the date is August 31, 2014.

» Press , , , , ,  for August 31, 2014. See Figure 10-2.

3. Press  to retain 08/31/14 as the date.

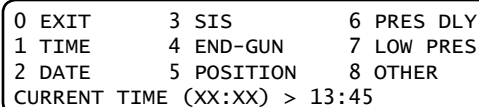

```
0 EXIT      3 SIS      6 PRES DLY
1 TIME     4 END-GUN  7 LOW PRES
2 DATE     5 POSITION  8 OTHER
CURRENT TIME (XX:XX) > 13:45
```

Figure 10-1

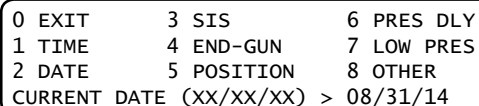

```
0 EXIT      3 SIS      6 PRES DLY
1 TIME     4 END-GUN  7 LOW PRES
2 DATE     5 POSITION  8 OTHER
CURRENT DATE (XX/XX/XX) > 08/31/14
```

Figure 10-2

Constants

Stop-In-Slot (SIS)

The Stop-In-Slot (SIS) feature stops the machine at one set position. The SIS factory default setting is OFF, with position set to 0.0° in both directions.

- If SIS is ON, the machine stops at this position every time.
- If SIS is OFF, the stop-in slot position is ignored.

NOTE

If a machine shuts down because SIS is ON:

- The SIS does NOT need to be turned off before the machine is started again.
- The SIS feature automatically disengages for 2° of pivot travel.
- The SIS feature automatically engages, and the machine shuts down again when it reaches the SIS position.

Edit SIS

To edit the current stop-in-slot position setting, follow these steps.

1. Press **SYSTEM**, **1**, **3** to display the SIS screen. See Figure 11-1.
2. Enter the desired stop-in-slot position in degrees.
3. Press **ENTER** to retain the value.

```
0 EXIT          3 SIS          6 PRES DLY
1 TIME         4 END-GUN      7 LOW PRES
2 DATE        5 POSITION     8 OTHER
STOP IN SLOT POSITION ( 0.0) >
```

Figure 11-1

System

Constants

End-Gun Sequences

A pivot can have up to 9 end gun sequences, numbered 1 through 9. Each sequence consists of a left angle and a right angle. The wedge between the left and right angle is where the end gun turns on.

The end gun sequence number does not affect when the end gun turns on or off. The end gun turns on or off based on the left angle and right angle entries.

End gun sequences operate the same whether or not the machine is running in the forward or reverse direction. See Figure 12-1.

- In the FORWARD direction, the end gun turns ON at the left angle and OFF at the right angle.
- In the REVERSE direction, the end gun turns ON at the right angle and OFF at the left angle.

Angles can be entered in tenths to fine tune the end gun setting. For example, an angle can be input as 300.6°. However, 300.6° is displayed as 300° on the status screen.

NOTE

To enable or disable the end gun, refer to End Gun in the Options section.

Typical Pivot End Gun Settings

Listed below are typical end gun settings for a pivot, based on the field size and end gun being used. Note that the pivot sectors are based on the location of 0° in relation to the pivot. See Figure 12-1 and the End Gun Settings table below it.

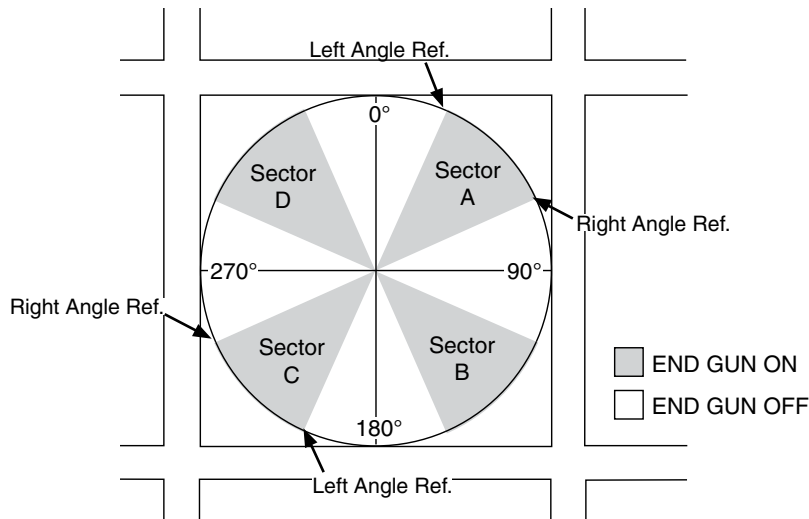

Figure 12-1

NOTE

These End Gun settings are approximate, and vary for different fields.

NUMBER OF ACRES	END GUN	SECTOR A		SECTOR B		SECTOR C		SECTOR D	
		LEFT ANGLE	RIGHT ANGLE	LEFT ANGLE	RIGHT ANGLE	LEFT ANGLE	RIGHT ANGLE	LEFT ANGLE	RIGHT ANGLE
40	NELSON 100	31	59	121	149	211	239	301	329
40	RAINBIRD 85	27	63	117	153	207	243	297	333
160	NELSON 100	21	69	111	159	201	249	291	339
160	RAINBIRD 85	18	72	108	162	198	252	288	342
640	NELSON 100	16	74	106	164	196	254	286	344
640	RAINBIRD 85	13	77	103	167	193	257	283	347

Constants / End Gun (continued) Setting Pivot End Gun Sequence

To set end gun sequences, follow these steps.

1. Press **SYSTEM**, **1**, **4** for the End Gun screen. See Figure 13-1.
2. Select a sequence number 1 through 9.
3. Enter the left angle. The angle can be input in tenths if needed. See Figure 13-2.

NOTE: The value shown in parenthesis indicates the current value.

4. Press **ENTER** to retain the value in degrees as the left angle.
5. Enter the right angle. The angle can be input in tenths. See Figure 13-3.
6. Press **ENTER** to retain the value in degrees as the right angle. These settings are now stored in memory.
7. Repeat steps 2 through 9 to set other sequences. See Figure 13-4. Or:
 - Press **ESC** to go back to the End Gun screen.
 - Press **SYSTEM** to return to the Status screen.

```
1  0 - 0  4  0 - 0  7  0 - 0
2  0 - 0  5  0 - 0  8  0 - 0
3  0 - 0  6  0 - 0  9  0 - 0
ENTER SEQUENCE TO CHANGE > 1
```

Figure 13-1

```
1  0 - 0  4  0 - 0  7  0 - 0
2  0 - 0  5  0 - 0  8  0 - 0
3  0 - 0  6  0 - 0  9  0 - 0
ENTER LEFT ANGLE ( 0.0) > 205
```

Figure 13-2

```
1  0 - 0  4  0 - 0  7  0 - 0
2  0 - 0  5  0 - 0  8  0 - 0
3  0 - 0  6  0 - 0  9  0 - 0
ENTER RIGHT ANGLE ( 0.0) > 250
```

Figure 13-3

```
1 205 - 250  4  0 - 0  7  0 - 0
2  0 - 0  5  0 - 0  8  0 - 0
3  0 - 0  6  0 - 0  9  0 - 0
ENTER SEQUENCE TO CHANGE >
```

Figure 13-4

System

Constants

Position

Position is the current pivot position in the field defined as a degree location between 0.0° and 359.9°, and shown on the status screen. Typically, the 0° pivot position is set to due north. However, any pivot location can be the 0° position. When setting up the position for a GPS system, the COM PORT must be set up first. The position of the pivot point must then be set before the pivot position.

Setting Up the COM Port

Refer to the COM PORT area of the Constants section of this manual for information about setting up the COM PORT.

Setting Pivot Position - No GPS

To set the current position, follow these steps.

1. Press **SYSTEM**, **1**, **5** for the Position screen. See Figure 14-1.
2. Press **3** for Pivot Position. See Figure 14-2.
3. Enter the desired position. See Figure 14-3.

NOTE: The value shown in parenthesis indicates the current value.

4. Press **ENTER** to retain the value.

Setting Pivot Point Position - With GPS

To set the pivot point, follow these steps:

1. Press **SYSTEM**, **1**, **5** for the Position screen. See Figure 14-1.
2. Press **1** for the Pivot Point screen. See Figure 14-2.
3. Press **2** for EDIT to edit the latitude and longitude positions manually. See Figure 14-4.

```
0 EXIT      3 SIS      6 PRES DLY
1 TIME     4 END-GUN  7 LOW PRES
2 DATE     5 POSITION  8 OTHER
CURRENT POSITION ( 0.0) >
```

Figure 14-1

```
0 EXIT      3 PIVOT POSITION
1 PIVOT POINT  4 DISTANCE TO GPS
2 POSITION LOSS
ENTER NUMBER >
```

Figure 14-2

```
CURRENT POSITION:      -> XXX.X
SAT COUNT:           LOCK:
LAT: (      ) LON: (      )
CURRENT POSITION (XXX.X) > XXX.X
```

Figure 14-3

```
POSITION:           START,      ( CURRENT )
LATITUDE:  - 30.291285,  (- 30.297895)
LONGITUDE: -127.738585,  (-127.738585)
PRESS 1..SET CURRENT 2..EDIT >
```

Figure 14-4

CAUTION

- SET CURRENT SHOULD ONLY BE USED BY AN AUTHORIZED VALLEY DEALER.
- SET CURRENT REQUIRES THE CONNECTION OF ADDITIONAL HARDWARE TO THE CONTROL PANEL, AND IS NOT RECOMMENDED FOR USE BY THE OWNER/OPERATOR OR ANY UNQUALIFIED PERSON.

4. Press **ENTER** to retain the value.
5. Press **SYSTEM** to return to the Status screen.

Constants / Position

Position Loss

The Position Loss constant is used when GPS is selected as the protocol. If the machine with GPS loses a signal, or has a loss of communication, the selected Position Loss commands occur. The three command options are listed below:

- Shutdown System - With this enabled, and if a loss of a signal or no communications to the GPS occurs for longer than the programmed delay, the machine logs the appropriate error code and system fault, and then shuts down.
- Disable Endguns - With this enabled, and a loss of a signal or no communications to the GPS occurs for longer than the programmed delay, the machine turns off the end gun and wide boundary outputs until the GPS signal is reacquired by the machine.
- Fallback Position - With the runtime enabled and the loss of the GPS signal, the position is calculated based on runtime until the GPS position is reacquired. Resolver is not recommended as a fallback for GPS position loss. Only Runtime should be used.

Setting Position Loss

To set the Position Loss constants, follow these steps.

1. Press , , for the Position screen. See Figure 15-1.
2. Press for the Position Loss screen. See Figure 15-2.
3. Press to enable Shutdown System. See Figure 15-3.
 - Press to activate or to deactivate Shutdown System. OFF is the default. See Figure 15-4.
4. If activated, enter the delay time in minutes. The default is 20 minutes. Press to retain the value. See Figure 15-5.
5. Press to disable the end guns. See Figure 15-3.
 - Press to activate or to deactivate Disable Endguns. OFF is the default. See Figure 15-6.
6. If activated, enter the delay time in minutes. The default is 10 minutes. Press to retain the value. See Figure 15-7.

```
0 EXIT          3 SIS          6 PRES DLY
1 TIME         4 END-GUN      7 LOW PRES
2 DATE        5 POSITION     8 OTHER
PRESS NUMBER >
```

Figure 15-1

```
0 EXIT          3 PIVOT POSITION
1 PIVOT POINT  4 DISTANCE TO GPS
2 POSITION LOSS
ENTER NUMBER >
```

Figure 15-2

```
IN EVENT OF GPS SIGNAL LOSS      *=ON
1 SHUTDOWN SYSTEM  3*FALLBACK POSITION
2 DISABLE ENDGUNS
PRESS NUMBER TO TOGGLE >
```

Figure 15-3

```
IN EVENT OF GPS SIGNAL LOSS      *=ON
1 SHUTDOWN SYSTEM  3*FALLBACK POSITION
2 DISABLE ENDGUNS
SYSTEM SHUTDOWN 1..ON 0..OFF >
```

Figure 15-4

```
IN EVENT OF GPS SIGNAL LOSS      *=ON
1 SHUTDOWN SYSTEM  3*FALLBACK POSITION
2 DISABLE ENDGUNS
SYSTEM SHUTDOWN DELAY MIN ( 20) >
```

Figure 15-5

```
IN EVENT OF GPS SIGNAL LOSS      *=ON
1*SHUTDOWN SYSTEM  3*FALLBACK POSITION
2 DISABLE ENDGUNS
DISABLE ENDGUNS 1..ON 0..OFF >
```

Figure 15-6

```
IN EVENT OF GPS SIGNAL LOSS      *=ON
1*SHUTDOWN SYSTEM  3*FALLBACK POSITION
2 DISABLE ENDGUNS
DISABLE ENDGUNS DELAY MIN ( 10) >
```

Figure 15-7

System

Constants

Setting Position Loss (continued)

- Press **3** to enable Fallback Position. See Figure 16-1.
- Press **1** to activate Fallback Position. See Figure 16-2.
- Press **1** to use Run Time. Runtime ON is the default.
- Press **ENTER** to retain the value. See Figure 16-3.
Resolver is not recommended as a fallback for GPS.
- Enter pivot speed. 15.56 ft./min. is the default. Press **ENTER** to retain the value. See Figure 16-4.

NOTE: The value shown in parenthesis indicates the current value.

- Enter pivot length. 1320 feet is the default. Press **ENTER** to retain the value. See Figure 16-5.

NOTE

Changing the pivot position affects the location in the field from which the end gun, wide boundary, stop-in-slot, and programs are controlled.

Setting Pivot Position

To set the pivot position, follow these steps.

- Press **SYSTEM**, **1**, **5** for the Position screen. See Figure 16-6.
- Press **3** for the Pivot Position screen.
- Enter the current pivot position from 0.0° to 359.9°. See Figure 16-7.

NOTE: The value shown in parenthesis indicates the current value.

- Press **ENTER** to retain the value.

```
IN EVENT OF GPS SIGNAL LOSS      *=ON
1*SHUTDOWN SYSTEM      3*FALLBACK POSITION
2*DISABLE ENDGUNS
PRESS NUMBER TO TOGGLE >
```

Figure 16-1

```
IN EVENT OF GPS SIGNAL LOSS      *=ON
1*SHUTDOWN SYSTEM      3*FALLBACK POSITION
2*DISABLE ENDGUNS
FALLBACK POSITION  1..ON  0..OFF >
```

Figure 16-2

```
IN EVENT OF GPS SIGNAL LOSS      *=ON
1*SHUTDOWN SYSTEM      3*FALLBACK POSITION
2*DISABLE ENDGUNS
SELECT 1..RUNTIME  2..RESOLVER (1) >
```

Figure 16-3

```
IN EVENT OF GPS SIGNAL LOSS      *=ON
1*SHUTDOWN SYSTEM      3*FALLBACK POSITION
2*DISABLE ENDGUNS
PIVOT SPEED FT/MIN (15.560) >
```

Figure 16-4

```
IN EVENT OF GPS SIGNAL LOSS      *=ON
1*SHUTDOWN SYSTEM      3*FALLBACK POSITION
2*DISABLE ENDGUNS
PIVOT LENGTH FT (1320) >
```

Figure 16-5

```
0 EXIT          3 PIVOT POSITION
1 PIVOT POINT
2 POSITION LOSS
ENTER NUMBER > 3
```

Figure 16-6

```
POSITION: 288.3 -> 175.6      PIVOT ?
SAT COUNT: 8      LOCK: DGPS
LAT: (-30.297895      LON: (-127.739125)
CURRENT POSITION (175.6) >
```

Figure 16-7

Constants

Set the Distance to GPS (The distance from pivot point to GPS tower box).

5. Press , , , for DISTANCE TO GPS. See Figure 17-1.
6. Enter the length from the pivot point to the GPS receiver. Do not enter the pivot length. The default is 1320 ft (402.3 m), and the range is 10 to 6554 ft (3.0 to 1997.6 m). See Figure 17-2.
7. Press to retain the value.
8. Enter the Plus tolerance for the length from pivot point to GPS receiver. The Default is 50 ft (15.2 m) and the range is 10 to 6554 ft (3.0 to 1997.6 m). A setting of 50 ft (15.2 m) or more is recommended to allow for variation in the GPS signal if Wide Area Application Services (WAAS) is unavailable. See Figure 17-3.
9. Press to retain the value.
10. Enter the Minus tolerance for the length from pivot point to GPS receiver. The Default is 50 ft (15.2 m) and the range is 10 to 6554 ft (3.0 to 1997.6 m). A setting of 50 ft (15.2 m) or more is recommended to allow for variation in the GPS signal if WAAS is unavailable. See Figure 17-4.
11. Press to retain the value.
12. Press to go back to the status screen.

```

0 EXIT                3 PIVOT POSITION
1 PIVOT POINT        4 DISTANCE TO GPS
2 POSITION LOSS
PRESS NUMBER >
    
```

Figure 17-1

```

0 EXIT                3 PIVOT POSITION
1 PIVOT POINT        4 DISTANCE TO GPS
2 POSITION LOSS
DISTANCE TO GPS (1320) FT >
    
```

Figure 17-2

```

0 EXIT                3 PIVOT POSITION
1 PIVOT POINT        4 DISTANCE TO GPS
2 POSITION LOSS
PLUS ( 50) FT >
    
```

Figure 17-3

```

0 EXIT                3 PIVOT POSITION
1 PIVOT POINT        4 DISTANCE TO GPS
2 POSITION LOSS
MINUS ( 50) FT >
    
```

Figure 17-4

System

Constants

Pressure Delay

Pressure Delay is used to set the Startup Pressure Delay and the Operating Pressure Delay constants.

Startup Pressure Delay bypasses the pressure transducer for the amount of time required in seconds for the machine to initially build water pressure above the low pressure limit after the pump has been started. The startup pressure delay has a range of 0 to 5000 seconds. The factory default is set to 600 seconds, or 10 minutes.

Operating Pressure Delay is active only after the startup pressure delay has expired. The operating pressure delay is the amount of time in seconds that the machine continues operating after pressure drops below the low pressure limit. The operating pressure delay has a range of 0 to 5000 seconds. The factory default is set to 30 seconds of continuous pressure loss. Operating pressure delay is reset when pressure rises above the low pressure limit.

If the water pressure does not reach the low pressure limit before the startup pressure delay expires, error code E06 PUMP SAFETY - PRESSURE TOO LOW AFTER PRESSURE DELAY is displayed on the STATUS screen, and the operating pressure delay takes over.

If the water pressure does not reach the low pressure limit before the operating pressure delay time expires, the machine is shut down due to a pressure fault, which is displayed on the DIAGNOSTICS System Faults screen and the System Status screen.

NOTE

If a mechanical pressure switch is used, the Startup Pressure Delay constant must be entered as the amount of time required for the pressure switch to close.

NOTE

To select the type of pressure sensor being used, refer to Pres Type in the System section.

Setting Pressure Delay

To set the pressure delay, follow these steps.

1. Press , , for the Startup Pressure Delay screen. See Figure 18-1.

2. Enter the desired Startup Pressure Delay time in seconds (default is 600 seconds).

NOTE: The value shown in parenthesis indicates the current value.

3. Press to retain the value.
4. Enter the desired Operating Pressure Delay time in seconds (default is 30 seconds). See Figure 18-2.
5. Press to retain the value.

```
0 EXIT      3 SIS      6 PRES DLY
1 TIME     4 END-GUN  7 LOW PRES
2 DATE     5 POSITION  8 OTHER
STARTUP PRES DLY IN SEC ( 600) >
```

Figure 18-1

```
0 EXIT      3 SIS      6 PRES DLY
1 TIME     4 END-GUN  7 LOW PRES
2 DATE     5 POSITION  8 OTHER
OPERATING PRES DLY IN SEC ( 30) >
```

Figure 18-2

Constants

Low Pressure Limit

Low Pressure Limit is used to set the water pressure minimum that must be met before the machine runs or continues running.

If the water pressure in the machine falls below the low pressure limit, and the pressure delays have expired, the machine and water supply (if wired to do so) shut down due to a pressure fault, which is displayed on the Diagnostics System Faults screen. The low pressure limit factory default setting is 15 psi (103 kPa).

Setting Low Pressure Limit

To set the low pressure limit, follow these steps.

1. Press , , for the Low Pressure Limit screen. See Figure 19-1.
2. Enter the desired low pressure limit in either Pounds Per Square Inch (psi) or Kilopascal (kPa).

NOTE: The value shown in parenthesis indicates the current value.

3. Press to retain value as the low pressure limit.

Minimum Application

Minimum Application is used to set the depth of water applied at a percentage timer setting of 100 percent.

The minimum application value is specific to the machine, and is used to calculate water applications at different machine speeds. Refer to the VChart Timer Report for this machine for this value, or contact your Valley dealer. The minimum application factory default setting is 0.250 inches (6.35 mm).

Setting Minimum Application

To set the minimum application, follow these steps.

1. Press , , , for the Minimum Application screen. See Figure 19-2.
2. Enter the minimum application from 0.001 to 1.000 in or 0.001 to 25.40 mm from the VChart timer report.

NOTE: The value shown in parenthesis indicates the current value.

3. Press to retain the value.

```

0 EXIT          3 SIS          6 PRES DLY
1 TIME         4 END-GUN     7 LOW PRES
2 DATE        5 POSITION    8 OTHER
LOW PRESSURE LIMIT ( 15) > XX
    
```

Figure 19-1

NOTE

If a mechanical pressure switch is used, set the Low Pressure Limit to 100 psi (689.4 kPa).

The switch should be adjusted manually, and should indicate either an open condition (low pressure) or a closed condition (sufficient pressure).

To select the type of pressure sensor to be used, refer to Pres Type in the SYSTEM section.

```

0 EXIT          3 VOLTAGE     6 RTU ID
1 MIN APP      4 WIDE BND   7 DAILY OPS
2 HRS/REV     5 FLOWMETER  8 OTHER
MINIMUM APPLICATION (0.250) > X.XX
    
```

Figure 19-2

System

Constants

Hours/Rev

Hours/Rev is used to set the number of hours required, at a percent timer setting of 100%, for the machine to make one complete revolution.

The Hours/Rev value is used to calculate hours per revolution for different percent timer settings, and is displayed on the Status screen. The Hours/Rev value is specific to the machine. Refer to your machine's VChart Timer Report for this value, or contact your Valley dealer. The Hours/Rev factory default setting is 24.0 hours.

Setting Hours/Rev

To set the Hours/Rev, follow these steps.

1. Press **SYSTEM**, **1**, **8**, **2** for the Time Per Revolution screen. See Figure 20-1.
2. Enter the hours per revolution from the VChart timer report at 100%.

NOTE: The value shown in parenthesis indicates the current value.

3. Press **ENTER** to retain value.

```
0 EXIT      3 VOLTAGE  6 RTU ID
1 MIN APP   4 WIDE BND 7 DAILY OPS
2 HRS/REV   5 FLOWMETER 8 OTHER
TIME PER REVOLUTION ( 24.0 ) > XX
```

Figure 20-1

Voltage

The Voltage constant calibrates the volt meter with the actual voltage coming into the control panel so that the voltage fluctuations can be monitored correctly.

The incoming voltage to the control panel must be measured with a meter by a qualified electrician or service person. This value is entered as the voltage constant.

The supply voltage should never exceed the limits shown in the Maximum Supply Voltage chart. See Figure 20-2.

Nominal Supply Voltage	Maximum Supply Voltage
480 VAC @ 60Hz	505 VAC
415 VAC @ 50Hz	420 VAC
400 VAC @ 50Hz	420 VAC
380 VAC @ 50Hz	420 VAC
230 VAC @ 60Hz	253 VAC
220 VAC @ 50Hz	243 VAC
120 VAC @ 60Hz	132 VAC
110 VAC @ 50Hz	121 VAC

Figure 20-2 Maximum Supply Voltage

Setting Voltage

To set the voltage, follow these steps.

1. Press **SYSTEM**, **1**, **8**, **3** for the Voltage screen. See Figure 20-3.
2. Enter the actual measured voltage.

NOTE: The value shown in parenthesis indicates the current value.

3. Press **ENTER** to retain value.

```
0 EXIT      3 VOLTAGE  6 RTU ID
1 MIN APP   4 WIDE BND 7 DAILY OPS
2 HRS/REV   5 FLOWMETER 8 OTHER
CURRENT VOLTAGE (480) > XXX
```

Figure 20-3

Constants

Wide Boundary

Wide Boundary sequences are used to control a corner machine sprinkler sequence, a second end gun, a span of sprinklers, or other electrically controlled devices. Figure 21-1 illustrates Wide Boundary on/off sequences.

Wide Boundary sequences are numbered 1 through 9. Each sequence has a left angle and a right angle. The wedge between the left and right angle is where Wide Boundary is turned on. The wide boundary sequence number does not affect when Wide Boundary turns on or off. Wide Boundary turns on or off based on the left angle and right angle entries.

Wide boundary sequences operate the same whether or not the machine is running in the forward or reverse direction through a sequence.

- In FORWARD, Wide Boundary turns ON at the left angle and OFF at the right angle. See Figure 21-1.
- In REVERSE, Wide Boundary turns ON at the right angle and OFF at the left angle. See Figure 21-1.

Angles can be entered in tenths to fine tune the wide boundary setting. However, an angle such as 300.6° is displayed as 300° on the screen.

Setting Wide Boundary

To set Wide Boundary sequences within a pivot zone, follow these steps.

1. Press **SYSTEM**, **1**, **8**, **4** for the Wide Boundary screen. See Figure 21-2.
2. Press **1** for Wide Boundary. See Figure 21-2.
3. Select a sequence number 1 to 9. See Figure 21-3.
4. Enter the left angle. The angle can be input in tenths of a degree, if needed. See Figure 21-4.

NOTE: The value shown in parenthesis indicates the current value.

5. Press **ENTER** to retain value as the left angle.
6. Enter the right angle. The angle can be input in tenths of a degree, if needed. See Figure 21-5.
7. Press **ENTER** to retain value as the right angle. These settings are now stored in memory.
8. Repeat steps 2 through 7 to set other sequences, or :
 - Press **ESC** for the Wide Boundary screen.
 - Press **SYSTEM** for the Status screen.

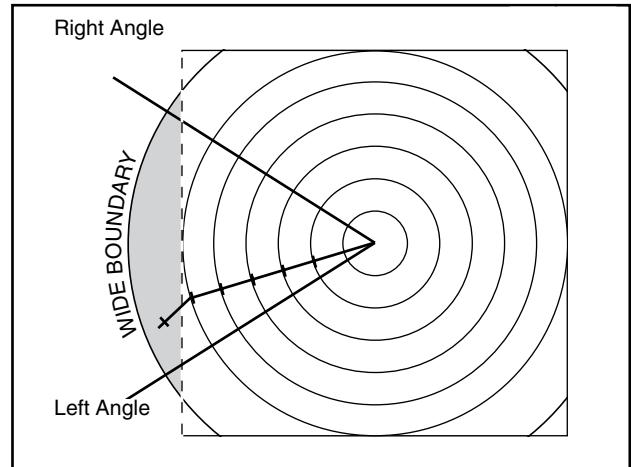

Figure 21-1

```

0 EXIT          1 WIDE BOUNDARY
                2 PLC WIDE BND#2
                3 PLC WIDE BND#3
ENTER WIDE BND TO CHANGE >
    
```

Figure 21-2

```

1 0 - 0 4 0 - 0 7 0 - 0
2 0 - 0 5 0 - 0 8 0 - 0
3 0 - 0 6 0 - 0 9 0 - 0
ENTER SEQUENCE TO CHANGE > X
    
```

Figure 21-3

```

1 0 - 0 4 0 - 0 7 0 - 0
2 0 - 0 5 0 - 0 8 0 - 0
3 0 - 0 6 0 - 0 9 0 - 0
ENTER LEFT ANGLE ( 0.0 ) > XXX.X
    
```

Figure 21-4

```

1 0 - 0 4 0 - 0 7 0 - 0
2 0 - 0 5 0 - 0 8 0 - 0
3 0 - 0 6 0 - 0 9 0 - 0
ENTER RIGHT ANGLE ( 0.0 ) > XXX.X
    
```

Figure 21-5

System

Constants

PLC Wide Boundary #2 and #3

The PLC Wide Boundary #2 and #3 sequences can be used to control a corner machine sprinkler sequence, a second end gun, a span of sprinklers, or other electrically controlled devices with a voltage of 120 VAC that does not exceed a continuous load current of 2 amps maximum. Figure 22-1 illustrates Wide Boundary on/off sequences.

Wide Boundary sequences are numbered 1 through 9. Each sequence has a left angle and a right angle. The wedge between the left and right angle is where Wide Boundary is turned on. The wide boundary sequence number does not affect when the wide boundary turns on or off. Wide Boundary turns on or off based on the left angle and right angle entries.

Wide boundary sequences operate the same whether or not the machine is running in the forward or reverse direction through a sequence.

- In FORWARD, Wide Boundary turns on at the left angle and off at the right angle. See Figure 22-1.
- In REVERSE, Wide Boundary turns on at the right angle and off at the left angle.

Angles can be entered in tenths to fine tune the wide boundary setting. However, an angle of 300.6° is displayed as 300° on the screen.

Setting PLC Wide Boundary Sequences

To set Wide Boundary sequences, follow these steps.

NOTE

PLC Wide Boundary #2 and #3 are only available when PLC WIDE BND is enabled in Protocol PLC Options screen.

To use PLC Wide Boundary #2 or #3, the machine must be equipped with a PLC wide boundary tower box.

The desired PLC Wide Boundary must be enabled in the Options/Other/End-Guns menu.

- Go to the Wide Boundary screen
 - Press , , , . See Figure 22-2.
 - To select the PLC wide boundary to be set, press or . See Figure 22-2.
 - Select a sequence number to modify. See Figure 22-3.
 - Enter the left angle. The angle can be input in tenths of a degree. See Figure 22-4.
 - Press .
 - Enter the right angle. The angle can be input in tenths of a degree. See Figure 22-5.
 - Press .
 - Repeat steps b) through g) to set other sequences.
- Press to return to the status screen.

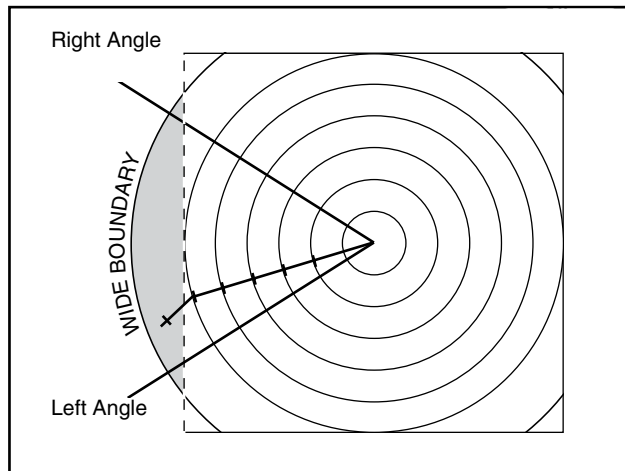

Figure 22-1

```

0 EXIT          1 WIDE BOUNDARY
                2 PLC WIDE BND#2
                3 PLC WIDE BND#3
ENTER WIDE BND TO CHANGE >
    
```

Figure 22-2

```

1 0 - 0 4 0 - 0 7 0 - 0
2 0 - 0 5 0 - 0 8 0 - 0
3 0 - 0 6 0 - 0 9 0 - 0
ENTER SEQUENCE TO CHANGE > X
    
```

Figure 22-3

```

1 0 - 0 4 0 - 0 7 0 - 0
2 0 - 0 5 0 - 0 8 0 - 0
3 0 - 0 6 0 - 0 9 0 - 0
ENTER LEFT ANGLE ( 0.0) > XXX.X
    
```

Figure 22-4

```

1 0 - 0 4 0 - 0 7 0 - 0
2 0 - 0 5 0 - 0 8 0 - 0
3 0 - 0 6 0 - 0 9 0 - 0
ENTER RIGHT ANGLE ( 0.0) > XXX.X
    
```

Figure 22-5

Constants

Flowmeter

Flowmeter calibrates the control panel with the optional flowmeter. Flowmeter constants (pulse multiplier values) are usually provided by the flowmeter manufacturer. The table below lists multiplier values for Valmont-supplied flow meters. See Figure 23-1.

The Flowmeter rate of flow is displayed on the System/Data/Flow/Wind/Temp screen in either gallons per minute (GPM) or liters per second (LPS), depending on the unit of measurement.

Setting Flowmeter Constant

Pipe Diameter (inches)	Gallons per Pulse Typical Values	Liters per Pulse	Max. GPM/RPM	Max. LPS/RPM
6	0.6250	2.366	1300/2080	82.02/2080
6-5/8	0.7407	2.804	1300/1755	82.02/1755
8	1.2500	4.732	2500/2000	157.72/2000
8-5/8	1.3514	5.116	2500/1850	157.82/1850
10	1.9231	7.280	3000/1560	189.27/1560

Figure 23-1 Valmont Supplied Flow Meter Multiplier Values

To set Flowmeter, follow these steps.

1. Press **SYSTEM**, **1**, **8**, **5** for the Flowmeter screen. See Figure 23-2.
2. Enter the manufacturer's recommended pulse multiplier value in either gallons per pulse or liters per pulse, depending on the unit of measure.

```

0 EXIT          3 VOLTAGE      6 RTU ID
1 MIN APP      4 WIDE BND     7 DAILY OPS
2 HRS/REV     5 FLOWMETER  8 OTHER
FLOWMETER GAL/PULSE ( 0.000) > 1.25
    
```

Figure 23-2

NOTE: The value shown in parenthesis indicates the current value.

3. Press **ENTER** to retain value.

RTU ID (Remote Telemetry Unit Identity)

The RTU ID is set only when an optional remote telemetry device is used to communicate with the control panel. The control panel RTU ID is a unique number between 1 and 997 that the user selects. None of the user's other control panels or BaseStations can have the same RTU ID number.

- RTU ID number 0 is the factory default setting for all RTU devices.
- RTU ID numbers 998 and 999 are typically reserved for use by a primary BaseStation.

Setting the RTU ID

To set the RTU ID constant, follow these steps:

1. Press **SYSTEM**, **1**, **8**, **6** to display the control module RTU ID screen. See Figure 23-3.
2. Enter the unique three-digit control module RTU ID.

```

0 EXIT          3 VOLTAGE      6 RTU ID
1 MIN APP      4 WIDE BND     7 DAILY OPS
2 HRS/REV     5 FLOWMETER  8 OTHER
RTU ID (0) > XXX
    
```

Figure 23-3

NOTE: The value shown in parenthesis indicates the current value.

3. Press **ENTER** to retain the value.

System

Constants

Daily Ops

Daily OPS is used to execute the START\$ or STOP\$ programs at set times on selected days. Daily OPS works in conjunction with any other program. There are two Daily OPS modes: Daily Operations mode and Load Management mode. Refer to Daily OPS program examples in the Step Program Examples section.

NOTE

For Daily OPS to work correctly in all applications, the START\$ must be programmed.

Daily Operations Mode

The Daily Operations mode has two functions:

1. Start and stop the machine at regular predefined times for selected days of the week.
2. Provide a load management shutdown mechanism with a lockout feature for energy rate contract eligibility.

When DAILY OPS is ON and Daily Operations Mode is selected/active, the following apply:

- If the current day is selected in Daily Start/Stop, and it is the start time, the START\$ program runs and the machine starts.
- If the start time comes before the stop time, and the current day is selected in Daily Start/Stop, and it is the stop time, the STOP\$ program runs and the machine stops.
- If the stop time comes before the start time, and the previous day is selected in Daily Start/Stop, and it is the stop time, the STOP\$ program runs and the machine stops.
- The machine shuts down if a start attempt is made outside of the daily start/stop time window. If the START button is pressed, the machine runs for five seconds without water, and a daily OPS fault is logged after the machine stops. Daily OPS must be turned OFF in order to run the machine outside of the daily start/stop time window.
- If the system time is changed to a time outside the daily start/stop time window, the machine shuts down.
- The Daily Operations mode can only be deactivated by pressing the STOP key or turning Daily OPS OFF.
- Stop-in-slot, auto-stop or a programmed stop WILL NOT deactivate the Daily Operations mode.

Load Management Mode

The Load Management mode has two functions.

- Start and stop the machine at regular predefined times for selected days of the week.
- Provide a load management shutdown mechanism without a lockout feature.

When DAILY OPS is on and the Load Management mode is selected and activated the following apply:

- If the current day is selected in Daily Start/Stop and it is the start time, the START\$ program is run and the machine starts.
- If the start time comes before the stop time, and the current day is selected in Daily Start/Stop, and it is the stop time, the STOP\$ program runs and the machine stops.
- If the stop time comes before the start time, and the previous day is selected in Daily Start/Stop, and it is the stop time, the STOP\$ program will NOT run. The machine continues to run until the next stop time on the next selected day in Daily Start/Stop, unless the user or a program stops the machine. Daily OPS does not stop the machine on days not selected for Daily OPS.
- The machine can be started at any time when Daily OPS is turned ON. The machine continues to run until a stop time and day is reached.
- When the Daily OPS is ON and the Load Management mode is selected, but not activated, if any start command occurs, load management is activated. The user can manually activate the Daily OPS/Load Management mode in daily ON/OFF.
- The Load Management mode is deactivated when any stop command other than a Daily OPS commanded stop occurs. The machine stops, and the mode is deactivated. If Daily OPS commanded the last stop, the Daily Operations mode remains activated.
- Stop-in-slot, auto-stop or a programmed stop deactivates the Load Management mode.

Constants/Daily OPS ON/OFF

Daily ON/OFF is used to turn Daily OPS ON or OFF, and select/activate the mode, either Daily Operations or Load Management. Daily OPS must be ON and the Daily Operations mode activated for the machine to start and stop on the specified days and times. The factory default setting is OFF.

Turning Daily OPS ON and activating the Daily Operations mode displays the restart message on the Status screen indicating that the machine can start at anytime. However, this does not automatically cause the power/pressure Autorestart to be active.

If Daily OPS is OFF, or if Daily OPS is ON but the mode is not activated, restart is not displayed on the Status screen.

If the machine is stopped by a pressure or power fault, and the Options/Autorestart is ON, the machine autorestarts unless the attempted autorestart is outside of the Daily Start/Stop time window. The Daily OPS mode is reactivated only if the Daily OPS mode was activated prior to the shutdown.

If the machine is stopped, either at the panel or remotely, the Restart function will not restart the machine at the Daily Start/Stop start time until the machine has been started again, or the mode is activated.

Setting DAILY ON/OFF

To set DAILY ON/OFF, follow these steps.

1. Press **SYSTEM**, **1**, **8**, **7**, **1** to display the Daily ON/OFF screen. See Figure 25-1.

2. Press **1** for ON or **0** for OFF.

NOTE: The value shown in parenthesis indicates the current value.

3. Press **1** for DAILY OPERATIONS or **2** for LOAD MANAGEMENT. See Figure 25-2.

4. If load management is selected, Press **1** for YES or **0** for NO. See Figure 25-3.

```

0 EXIT                3 CYCLE ON/OFF
1 DAILY ON/OFF       4 CYCLE INTERVAL
2 DAILY START/STOP  5 CYCLE START TIME
DAILY OPS (OFF) 1..ON 0..OFF >
    
```

Figure 25-1

```

0 EXIT                3 CYCLE ON/OFF
1 DAILY ON/OFF       4 CYCLE INTERVAL
2 DAILY START/STOP  5 CYCLE START TIME
MODE (1) 1..DAILY OPS 2..LOAD MNG. >
    
```

Figure 25-2

```

0 EXIT                3 CYCLE ON/OFF
1 DAILY ON/OFF       4 CYCLE INTERVAL
2 DAILY START/STOP  5 CYCLE START TIME
ACTIVATE (0) 1..YES 0..NO >
    
```

Figure 25-3

System

Constants/Daily OPS

Daily Start/Stop

Daily Start/Stop is used to set the daily machine start time, daily machine stop time, and day(s) of the week for Daily OPS to be active. Daily start and stop times are entered in 24 hour clock format. For example, a time of 6:00 PM is entered as 18:00:00 hours or a time of 10:00 AM is entered as 10:00:00 hours.

Setting Daily Start/Stop

To set Daily Start/Stop, follow these steps.

1. Press , , , , to display the Daily Start/Stop screen. See Figure 26-1.

2. Enter the desired daily machine start time in 24 hour clock format.

NOTE: The value shown in parenthesis indicates the current value.

3. Press to retain the desired daily start time.
4. Enter the desired daily machine stop time in 24 hour clock format. See Figure 26-2.
5. Press to retain the desired daily stop time.
6. Select the desired day or days of the week that Daily OPS is active. See Figure 26-3.

= Sunday

= Monday

= Tuesday

= Wednesday

= Thursday

= Friday

= Saturday

7. Press to retain the desired day(s) for Daily OPS to be active.

```
0 EXIT          3 CYCLE ON/OFF
1 DAILY ON/OFF  4 CYCLE INTERVAL
2 DAILY START/STOP 5 CYCLE START TIME
ENTER TIME TO START (00:00) > XX:XX:XX
```

Figure 26-1

```
0 EXIT          3 CYCLE ON/OFF
1 DAILY ON/OFF  4 CYCLE INTERVAL
2 DAILY START/STOP 5 CYCLE START TIME
ENTER TIME TO STOP (00:00) > XX:XX:XX
```

Figure 26-2

```
0 EXIT    3 TUESDAY    6 FRIDAY
1 SUNDAY  4 WEDNESDAY  7 SATURDAY
2 MONDAY  5 THURSDAY
ENTER DAYS (1,2,3,4,5,6,7,) >
```

Figure 26-3

Constants/Daily OPS

Cycle ON/OFF

Cycle ON/OFF is used to turn repeat cycles on and off. The repeat cycles feature is used for repeating the CYCLE\$ program at specified times. The CYCLE\$ program must be written, and the cycle must be on for the feature to work.

Activating Cycle ON displays the restart message on the status screen, indicating that the machine may start at anytime. However, this does not activate the Autorestart option. The Daily OPS, Daily Operations mode, or Load Management mode can be used in conjunction with the Repeat Cycle function. The machine only runs during the days and times allowed.

Setting Cycle ON/OFF

To set Cycle ON/OFF, follow these steps.

1. Press **SYSTEM**, **1**, **8**, **7**, **3** to display the Repeat Cycle screen. See Figure 27-1.
2. Press **1** for ON or **0** for OFF.

NOTE: The value shown in parenthesis indicates the current value.

```

0 EXIT                3 CYCLE ON/OFF
1 DAILY ON/OFF       4 CYCLE INTERVAL
2 DAILY START/STOP   5 CYCLE START TIME
REPEAT CYCLE (OFF) 1..ON 0..OFF > X
    
```

Figure 27-1

Cycle Interval

Cycle Interval is used to set the number of days between irrigations, or cycles. The machine MUST make a complete circle, or two partial circles (forward and reverse pass in the case of a windshield wiper machine) in the desired cycle interval. The time required to complete one cycle must be less than the cycle interval.

Setting Cycle Interval

To set Cycle Interval, follow these steps.

1. Press **SYSTEM**, **1**, **8**, **7**, **4** to display the Cycle Interval screen. See Figure 27-2.
2. Enter the desired number of days from 1 to 99 between irrigations or cycles.

NOTE: The value shown in parenthesis indicates the current value.

3. Press **ENTER** to retain the desired number of days between irrigations, or cycles.

```

0 EXIT                3 CYCLE ON/OFF
1 DAILY ON/OFF       4 CYCLE INTERVAL
2 DAILY START/STOP   5 CYCLE START TIME
CYCLE INTERVAL ( 7 DAYS) > X
    
```

Figure 27-2

The following situations occur if the machine does not complete a cycle in the specified time interval.

1. The machine is running. The next cycle date and time is reached, and the machine has not completed the full cycle. In this situation, the machine continues to run to the stop-in-slot position, and stops. The operator is then required to start the machine manually to resume the irrigation cycle.
2. The machine is stopped. The next cycle date and time is reached, and the machine has not completed the full cycle. This situation requires the operator to start the machine. The machine then runs to the stop-in-slot position. It does not stop at the stop-in-slot, but continues its travel. The operator then needs to execute a cycle manually by pressing **OPTIONS**, **5** for CYCLE\$, **3** for EXECUTE, **1** for 1 cycle, and **ENTER**. This enters a cycle, and resumes the irrigation schedule.

System

Constants/Daily OPS

Cycle Start Time

Cycle Start Time is used to set the irrigation or cycle start time, daily machine stop time, and day(s) of the week for Daily Ops to be active. Cycle Start Time is entered in the 24 hour clock format. For example a time of 6:00 PM is entered as 18:00:00 hours, or a time of 10:00 AM is entered as 10:00:00 hours.

Setting Cycle Start Time

To set Cycle Start Time, follow these steps.

1. Press **SYSTEM**, **1**, **8**, **7**, **5** to display the Cycle Start Time screen. See Figure 28-1.
2. Enter the desired time to start irrigations, or cycles, in the 24 hour clock format.

NOTE: The value shown in parenthesis indicates the current value.

3. Press **ENTER** to retain the desired start time.

```
0 EXIT          3 CYCLE ON/OFF
1 DAILY ON/OFF  4 CYCLE INTERVAL
2 DAILY START/STOP 5 CYCLE START TIME
ENTER TIME TO START (00:00) > XX:XX:XX
```

Figure 28-1

Wind

WIND is used to set the wind speed high limit, and turn the wind high limit shutdown ON or OFF. When the wind high limit shutdown is ON, and the wind high limit is reached, the machine shuts down. The Wind High Limit factory default setting is 15 miles per hour (6.7 meters per second).

Setting Wind

To set Wind High Limit, or turn the wind high limit shutdown ON or OFF, follow these steps.

1. Press **SYSTEM**, **1**, **8**, **8**, **1** to display the Wind High Limit screen. See Figure 28-2.
2. Enter the desired wind speed high limit.

NOTE: The value shown in parenthesis indicates the current value.

3. Press **ENTER** to retain the value.
4. Turn the wind high limit shutdown ON or OFF by pressing **1** or **0**. See Figure 28-3.

```
0 EXIT  3 PERCENT TIMER  6 ENGINE/PUMP
1 WIND  4 LOW VOLTAGE   7 COM PORT
2 AR/AS 5 DIR OFFSET   8 OTHER
WIND HIGH LIMIT ( 15 ) > XX
```

Figure 28-2

```
0 EXIT  3 PERCENT TIMER  6 ENGINE/PUMP
1 WIND  4 LOW VOLTAGE   7 COM PORT
2 AR/AS 5 DIR OFFSET   8 OTHER
1..ON  0..OFF ( OFF ) > X
```

Figure 28-3

Constants

AR/AS (Auto Reverse/Auto Stop)

AR/AS is used to enable or disable the Automatic Reverse/Automatic Stop option, and to set the delay time when a machine is equipped with a drive-unit-mounted end-of-field stop/auto reverse. If the machine is NOT equipped with a drive-unit-mounted end-of-field auto stop/auto reverse, leave this constant OFF. The AR/AS factory default setting is OFF. The AR/AS delay time factory default setting is 0 seconds.

- If AR/AS is on, water is on, and the Auto Reverse/Auto Stop option is set to Auto Reverse, when the actuator arm is tripped the machine changes direction, disables the percent timer, waits for the set AR/AS delay time, and then enables the percent timer and continues running.
- If AR/AS is on, water is on, and the Auto Reverse/Auto Stop option is set to Auto Stop, when the actuator arm is tripped the machine changes directions, disables the percent timer, waits for the set AR/AS delay time, and then shuts down.
- AR/AS delay only occurs when AR/AS is on, water is on, and an AR/AS event has occurred.
- If AR/AS is off, the machine shuts down when the actuator arm is tripped.

CAUTION

•WHEN A MACHINE MUST REVERSE AROUND AN OBSTACLE, A DRIVE-UNIT-MOUNTED END-OF-FIELD AUTO STOP/AUTO REVERSE MUST BE INSTALLED WITH PHYSICAL BARRIERS AS A SAFETY BACK-UP.

NOTE

Refer to Auto Reverse in the Options section to select which option to use, either Auto Reverse or Auto Stop.

Enabling AR/AS

To enable the AR/AS option, and set the delay time, follow these steps.

1. Press **SYSTEM**, **1**, **8**, **8**, **2** to display the AR/AS screen. See Figure 29-1.

```
0 EXIT      3 PERCENT TIMER  6 ENGINE/PUMP
1 WIND     4 LOW VOLTAGE  7 COM PORT
2 AR/AS    5 DIR OFFSET  8 OTHER
AR/AS 1..ON 0..OFF (OFF) > 1
```

Figure 29-1

2. Press **1** for ON (enables the AR/AS option).

NOTE: The value shown in parenthesis indicates the current value.

3. Enter the desired AR/AS Delay Time in seconds. See Figure 29-2.

```
0 EXIT      3 PERCENT TIMER  6 ENGINE/PUMP
1 WIND     4 LOW VOLTAGE  7 COM PORT
2 AR/AS    5 DIR OFFSET  8 OTHER
AR/AS DELAY IN SECONDS ( 0) > XXX
```

Figure 29-2

4. Press **ENTER** to retain the value.

Disabling AR/AS

To disable the AR/AS option, follow these steps.

1. Press **SYSTEM**, **1**, **8**, **8**, **2** to display the AR/AS screen. See Figure 29-3.

NOTE: The value shown in parenthesis indicates the current value.

2. Press **0** to turn the auto reverse function OFF.

```
0 EXIT      3 PERCENT TIMER  6 ENGINE/PUMP
1 WIND     4 LOW VOLTAGE  7 COM PORT
2 AR/AS    5 DIR OFFSET  8 OTHER
AR/AS 1..ON 0..OFF ( ON) > 0
```

Figure 29-3

System

Constants

Percent Timer

Percent Timer is used to set the Percent Timer cycle time. The Percent Timer cycle time factory default setting is 60 seconds. When the Percent Timer cycle time is set at 60 seconds, and the Percent Timer is set at 50 percent, the end tower moves for 30 seconds of each minute. The percent timer cycle time can be set from 20 to 200 seconds.



CAUTION

•INCREASING THE PERCENT TIMER CYCLE TIME SETTING OVER 60 SECONDS MAY CAUSE UN-EVEN WATER DISTRIBUTION.

Setting Percent Timer

To set the Percent Timer cycle time, follow these steps.

1. Press **SYSTEM**, **1**, **8**, **8**, **3** to display the Percent Timer Cycle Time screen. See Figure 30-1.

2. Enter the percent timer cycle time in seconds.

NOTE: The value shown in parenthesis indicates the current value.

3. Press **ENTER** to retain the value.

```
0 EXIT      3 PERCENT TIMER  6 ENGINE/PUMP
1 WIND     4 LOW VOLTAGE   7 COM PORT
2 AR/AS    5 DIR OFFSET    8 OTHER
PERCENT TIMER CYCLE IN SEC. ( 60) > XX
```

Figure 30-1

Constants

Low Voltage

The Low Voltage constant is used to set the low voltage limit. The low voltage limit factory default setting is 440 volts for use with a supply voltage of 480 VAC @ 60Hz. Recommended low voltage limits for other supply voltages are shown in the Recommended Low Voltage chart. See Figure 31-1.

If the control panel voltmeter senses voltage below the low voltage limit, a built-in timer keeps the machine running for up to 15 seconds to prevent nuisance shutdowns due to voltage fluctuations.

If the low voltage condition still exists after 15 seconds, the machine will be shut down and the diagnostics screen will display a fault for machine power.

Nominal Supply Voltage	Recommended Low Voltage Setting
480 VAC @ 60Hz	440 VAC
415 VAC @ 50Hz	375 VAC
400 VAC @ 50Hz	365 VAC
380 VAC @ 50Hz	355 VAC
230 VAC @ 60Hz	220 VAC
220 VAC @ 50Hz	210 VAC
120 VAC @ 60Hz	105 VAC
110 VAC @ 50Hz	95 VAC

Figure 31-1 Recommended Low Voltage

CAUTION

- DO NOT SET LOW VOLTAGE LOWER THAN THE RECOMMENDED LOW VOLTAGE LIMIT.
- LOW VOLTAGE WILL DAMAGE THE DRIVE MOTORS AND OTHER ELECTRICAL COMPONENTS. CORRECT THE PROBLEM BEFORE RESUMING OPERATION

Setting Low Voltage

To set the low voltage limit, follow these steps.

1. Press **SYSTEM**, **1**, **8**, **8**, **4** to display the Low Voltage screen. See Figure 31-2.
2. Enter the desired low voltage limit.

NOTE: The value shown in parenthesis indicates the current value.

3. Press **ENTER** to retain the value.

```

0 EXIT      3 PERCENT TIMER  6 ENGINE/PUMP
1 WIND     4 LOW VOLTAGE  7 COM PORT
2 AR/AS    5 DIR OFFSET  8 OTHER
LOW VOLTAGE LIMIT (440) >
    
```

Figure 31-2

System

Constants

Dir Offset

Dir Offset (Direction Offset) is used to adjust, or offset, the actual pivot position of the machine so that the End Gun on/off locations, Wide Boundary on/off locations, Stop-In-Slot locations, or any other position-based command locations are repeatable when the direction of the machine is changed. A repeatable accuracy of $\pm 1^\circ$ can be expected. The Dir Offset factory default setting is 0.5° and is adjustable from 0° to 10° .

Estimating the Direction Offset

If, after changing directions, the machine runs/stops past the normal End Gun on/off locations, Wide Boundary on/off locations, Stop-In-Slot location or any other position based program locations by an estimated value of 1.0° , the direction offset needs to be increased by $1/2$ of the estimated value, which in this case is 0.5° . See Figure 32-1.

1. Measure the distance in feet from where the machine stopped to where it should have stopped. This is the measured offset.

Measured Offset _____

2. The table in Figure 32-2 lists the approximate length of a 1° offset, based on machine length. Find and record the approximate 1° offset for your machine length.

Approximate Offset _____

3. Calculate the value for the estimated offset, based on whether the machine runs/stops past or runs/stops short of the position. Then set the new direction offset. See Figure 32-3.

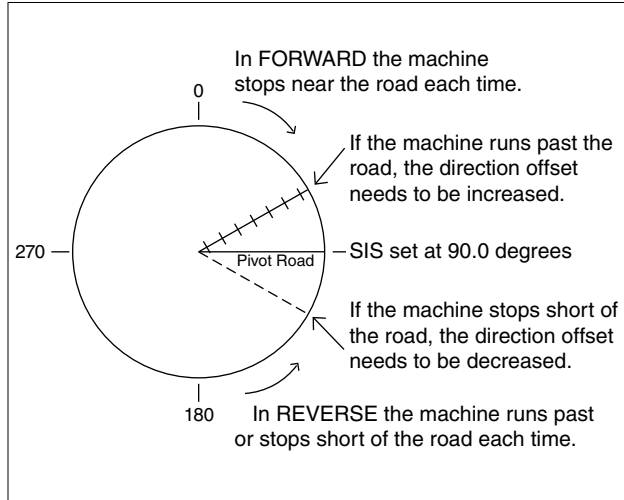

Figure 32-1

Machine Length (Feet)	115	230	345	460	575	690	805	920	1035	1150	1265	1380	1495	1610	1725
1 Degree Offset (Feet)	2	4	6	8	10	12	14	16	18	20	22	24	26	28	30

Machine Length (Meters)	35.0	70.1	105.1	140.2	175.2	210.3	245.3	280.4	315.4	350.5	385.5	420.6	455.6	490.7	525.7
1 Degree Offset (Meters)	0.6	1.2	1.8	2.4	3.0	3.6	4.2	4.8	5.4	6.0	6.7	7.3	7.9	8.5	9.1

Figure 32-2 Estimated Direction Offsets

Machine Runs/Stops Past Position:				Machine Runs/Stops Short of Position:			
Estimated Direction Offset	=	Current Direction Offset +	$\frac{\text{Measured (Offset)}}{2}$	Estimated Direction Offset	=	Current Direction Offset -	$\frac{\text{Measured (Offset)}}{2}$
			$\frac{(\quad \div \quad)}{2}$				$\frac{(\quad \div \quad)}{2}$
			$\frac{(\quad)}{2}$				$\frac{(\quad)}{2}$

Figure 32-3 Estimated Offset Calculation Form

Constants/Dir Offset

Calculating Direction Offset

To calculate the direction offset value, follow these steps.

1. Start the machine in the FORWARD or REVERSE running direction, and watch the position reading on the Status screen. For this example, the running direction used is REVERSE.

Stop the machine when the position changes by at least 7°. This indicates that the resolver is now turning as the pivot rotates.

2. Place a flag next to the wheel track and in line with the center of the rear wheel on the first regular drive unit. This is position A. See Figure 33-1.

In the running direction opposite to that in step 1, measure a distance of 50 feet from position A along the first regular drive unit wheel track, and place another flag. This is position B. For this example, the opposite running direction is FORWARD.

3. Press **SYSTEM**, **1**, **5** to display the current position of the machine. See Figure 33-2.

Record the current position displayed at the bottom of the screen to the nearest tenth of a degree as position A.

Position A = _____ Degrees

4. Start the machine in the running direction opposite of that in step 1, and let it run exactly 50 feet. The flag at position B should be in line with the center of the rear wheel on the first regular drive unit. Then, stop the machine.

5. Press **SYSTEM**, **1**, **5** to display the current position of the machine.

Record the current position displayed at the bottom of the screen to the nearest tenth of a degree as position B.

Position B = _____ Degrees

6. Measure the distance in feet from the center of the pivot to the center line of the tire on the first regular drive unit. This distance is R. See Figure 33-3.

R = _____ Feet

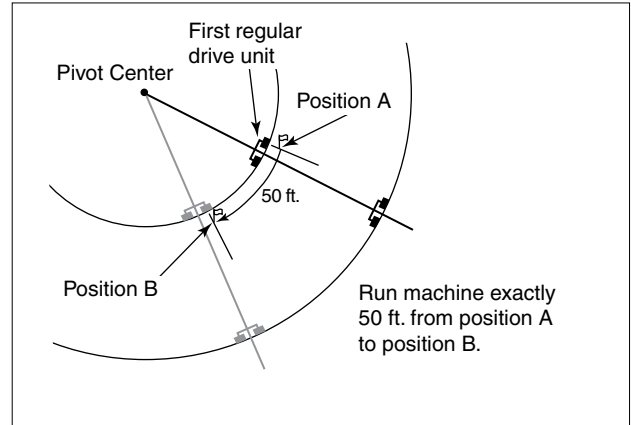

Figure 33-1

0 EXIT	3 SIS	6 PRES DLY
1 TIME	4 END-GUN	7 LOW PRES
2 DATE	5 POSITION	8 OTHER
CURRENT POSITION (323.6) > XXX.X		

Figure 33-2

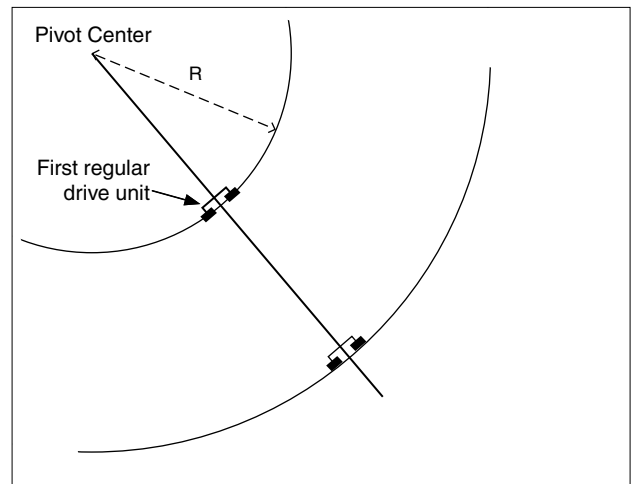

Figure 33-3

System

Constants/Dir Offset/Calculating Direction Offset (continued)

7. Use the measured degrees formula to determine how many degrees the pivot should travel in 50 feet. This is the measured degrees. See Figure 34-1.

8. Use the actual degrees formula to determine the actual degrees traveled. This is the difference in readings between position A and position B.

NOTE: If this value is negative, drop the negative sign and use as a positive value.

9. Press **SYSTEM**, **1**, **8**, **8**, **5** to view the direction offset screen. See Figure 34-2.

Record the current direction offset displayed at the bottom of the screen.

Current Direction Offset = _____

10. Calculate the value for the new direction offset using one of the two formulas shown below. Then set the new direction offset. See Figure 34-3.

Measured Degrees Formula

$$\begin{aligned} \text{Measured Degrees} &= (2864.8) / (R) \\ &= (2864.8) / (\text{_____}) \\ &= \text{_____} \end{aligned}$$

Actual Degrees Formula

$$\begin{aligned} \text{Actual Degrees} &= \text{Position B} - \text{Position A} \\ &= (\text{_____}) - (\text{_____}) \\ &= \text{_____} \end{aligned}$$

Figure 34-1 Formulas

```
0 EXIT    3 PERCENT TIMER  6 ENGINE/PUMP
1 WIND    4 LOW VOLTAGE   7 COM PORT
2 AR/AS   5 DIR OFFSET    8 OTHER
DIRECTION OFFSET ( 0.5 ) >
```

Figure 34-2

If the actual degrees are LESS THAN the measured degrees use the formula below:

$$\begin{aligned} \text{New Direction Offset} &= \text{Current Direction Offset} + \left[\frac{(\text{Measured Degrees}) - (\text{Actual Degrees})}{2} \right] \\ &= \text{_____} + \left[\frac{(\text{_____}) - (\text{_____})}{2} \right] \\ &= \text{_____} + \left[\frac{(\text{_____})}{2} \right] \\ &= \text{_____} + \text{_____} \\ &= \text{_____} \end{aligned}$$

If the actual degrees are GREATER THAN the measured degrees use the formula below:

$$\begin{aligned} \text{New Direction Offset} &= \text{Current Direction Offset} - \left[\frac{(\text{Actual Degrees}) - (\text{Measured Degrees})}{2} \right] \\ &= \text{_____} - \left[\frac{(\text{_____}) - (\text{_____})}{2} \right] \\ &= \text{_____} - \left[\frac{(\text{_____})}{2} \right] \\ &= \text{_____} - \text{_____} \\ &= \text{_____} \end{aligned}$$

Figure 34-3 Direction Offset Formulas

Setting Dir Offset

To set the direction offset, follow these steps:

1. Press **SYSTEM**, **1**, **8**, **8**, **5** to display the direction offset screen. See Figure 34-4.

2. Enter the desired pivot direction offset value.

NOTE: The value shown in parenthesis indicates the current value being used by the control module.

3. Press **ENTER** to retain the value.

```
0 EXIT    3 PERCENT TIMER  6 ENGINE/PUMP
1 WIND    4 LOW VOLTAGE   7 COM PORT
2 AR/AS   5 DIR OFFSET    8 OTHER
DIRECTION OFFSET ( 0.5 ) >
```

Figure 34-4

Constants

Engine/Pump

ENGINE/PUMP is used to select and control the type of pumping unit that is being used with the machine. The factory default setting for engine/pump is PUMP.

ENGINE indicates a combustion engine is being used as the power for operating the pump. The ENGINE mode keeps the pump safety relay engaged while the machine is running, water on or water off, and disengages the relay when the machine is stopped. The factory default shutdown sequence for the engine setting is ALT.

PUMP indicates an electric motor is being used to operate the pumping unit. The PUMP mode engages the pump safety relay when water is turned on, and disengages the relay when water is turned off.

NOTE

It is always recommended that ALT be used instead of NORMAL when using the ENGINE setting so that safety faults get properly recorded.

Setting Engine/Pump

To set the control panel to ENGINE or PUMP, follow these steps.

1. Press **SYSTEM**, **1**, **8**, **8**, **6** to display the Engine/Pump screen. See Figure 35-1.

```
0 EXIT      3 PERCENT TIMER  6 ENGINE/PUMP
1 WIND      4 LOW VOLTAGE  7 COM PORT
2 AR/AS     5 DIR OFFSET   8 OTHER
1..ENGINE  0..PUMP ( PUMP ) >
```

Figure 35-1

2. Select the type of pumping unit.

- Press **1** for ENGINE or **0** for PUMP.

NOTE: The value shown in parenthesis indicates the current value.

3. If the pumping unit is engine-driven, select the shutdown sequence. See Figure 35-2.

```
0 EXIT      3 PERCENT TIMER  6 ENGINE/PUMP
1 WIND      4 LOW VOLTAGE  7 COM PORT
2 AR/AS     5 DIR OFFSET   8 OTHER
SHUTDOWN  1..NORMAL 0..ALT (0) >
```

Figure 35-2

- Press **1** for NORMAL or **0** for ALT (recommended).
 - » NORMAL stops the machine and disengage the engine simultaneously after a 3.0 second delay. However, this incorrectly logs a safety shutdown as a power fault.
 - » ALT (Alternate) stops the machine after a 1.5 second delay. This allows 1.5 seconds for the Pro2 module to save the updated status, then disengage the engine.

The ALT shutdown sequence is required for saving the event on the History Review screen and the Diagnostics log before power is gone.

System

Constants

Com Port

Com Port is used to set the control panel communications port, protocol, and baud rate for information that is transmitted and received when communicating with another computer. The baud rate must be set to match the other computer or communications equipment connected to the Pro2 control module.

- The 9-PIN COM PORT is used as the telemetry connection for remote communications. The baud rate is factory set at 9600.
- The 25-PIN COM PORT is used for direct connections to an option or by Valley Dealers for service related functions. The baud rate is factory set at 57600.
- The 9-PIN Y-CABLE PORT is reserved for future applications. The baud rate is factory set at 9600.
- The 9-PIN PROTOCOL is factory set to PLC.
- The 25-PIN PROTOCOL is factory set to SERVICE TOOL.
- The 9-PIN Y-CABLE PROTOCOL is factory set to NONE.

Setting Com Port

To set communications port, baud rate and protocol, follow these steps.

1. Press **SYSTEM**, **1**, **8**, **8**, **7** to display the Com Port screen. See Figure 36-1.

2. Select the desired communications port:

1 = 9-PIN COM PORT.

2 = 25-PIN COM PORT.

3 = 9-PIN Y-CABLE

3. Press **1** for PROTOCOL. Selections 3, 4, and 5 may not appear. See Figure 36-2.

4. Select the desired protocol for the communications port. See Figure 36-3.

1 = REMOTE CTL. **5** = REMOTE CTL V2

2 = SERVICE TOOL. **6** = GPS V1

3 = PLC. **7** = NONE

```
0 EXIT                3 9-PIN Y-CABLE
1 9-PIN COM PORT
2 25-PIN COM PORT
PRESS NUMBER >
```

Figure 36-1

```
0 EXIT                3 HW FLOW CTRL
1 PROTOCOL           4 KEY WAIT
2 BAUD RATE          5 CONFIG NOTICE
PRESS NUMBER >
```

Figure 36-2

```
0 EXIT                3 PLC                6 GPS V1
1 REMOTE CTL         4 NA                 7 NONE
2 SERVICE TOOL       5 REMOTE CTL V2
SELECT PROTOCOL (1) >
```

Figure 36-3

NOTE: A protocol can be used by any Com Port, but it cannot be used by all Com Ports at the same time.

Remote Control

When the Remote Control protocol is selected, additional settings are required for communications hardware and the real-time update function.

1. Press **SYSTEM**, **1**, **8**, **8**, **7**, **1**, **1** to display the com port protocol screen. See Figure 36-4.

2. Press **1** for the remote control screen. See Figure 36-5.

NOTE: Remote Control V2 is not used at this time.

```
0 EXIT                3 PLC                6 GPS V1
1 REMOTE CTL         4 NA                 7 NONE
2 SERVICE TOOL       5 REMOTE CTL V2
SELECT PROTOCOL (1) >
```

Figure 36-4

```
0 EXIT                3 HW FLOW CTRL
1 PROTOCOL           4 KEY WAIT
2 BAUD RATE          5 CONFIG NOTICE
PRESS NUMBER >
```

Figure 36-5

Constants/Com Port/Remote Control

Hardware Flow Control

HW FLOW CONTROL is used to set how the control panel communications hardware sends and receives information. The hardware flow control factory default setting is NONE.

NOTE

Hardware Flow Control is only available when the Com Port protocol has been set up as Remote Control.

To set the hardware flow control to be used by the control panel, do the following.

1. Press **SYSTEM**, **1**, **8**, **8**, **7**, **1**, **3** to display the Hardware Flow Control screen. See Figure 37-1.

NOTE: The value shown in parenthesis indicates the current value.

```

0 EXIT          3 HW FLOW CTRL
1 PROTOCOL     4 KEY WAIT
2 BAUD RATE    5 CONFIG NOTICE
FLOW CTL 0..NONE 1..CTS 2..DCD (NONE) > X
    
```

Figure 37-1

2. Select the desired type of hardware flow control.

- Press **0** for NONE.
- Press **1** for CTS (Clear To Send).
- Press **2** for DCD (Data Carrier Detect).

Set to NONE if hardware does not support CTS or DCD.

Key Wait

KEY WAIT is used to set the radio key wait time before transmission of data. The Key Wait factory default setting is 0.0 seconds. High Speed Key Wait is used for high speed communications hardware. The default is OFF. High Speed Key Wait is reserved for future applications.

NOTE

Key Wait is only available when the Com Port protocol has been set up as Remote Control.

To set the Key Wait time, follow these steps.

1. Press **SYSTEM**, **1**, **8**, **8**, **7**, **1**, **4** to display the key wait screen. See Figure 37-2.

NOTE: The value shown in parenthesis indicates the current value.

```

0 EXIT          3 HW FLOW CTRL
1 PROTOCOL     4 KEY WAIT
2 BAUD RATE    5 CONFIG NOTICE
HIGH SPEED 1..ON 0..OFF (OFF) > 0
    
```

Figure 37-2

2. Press **0** to turn high speed OFF.
3. Enter the desired key wait time. See Figure 37-3.
4. Press **ENTER** to retain the value.

```

0 EXIT          3 HW FLOW CTRL
1 PROTOCOL     4 KEY WAIT
2 BAUD RATE    5 CONFIG NOTICE
KEY WAIT (0.0) >
    
```

Figure 37-3

System

Constants/Com Port/Remote Control

Config Notice

Use CONFIG NOTICE to set up the control panel for communications with BaseStation2. Configure the following according to the application and the communications hardware used at the control panel and the BaseStation2.

NOTE

CONFIG Notice is only available when the Com Port protocol has been set up as Remote Control.

Base ID (For Notice Option Callout only)

Use Base ID to set the BaseStation2 identification number in the control panel. The factory default setting is 999.

To set the Base ID, do the following.

5. Press , , , , , , , to display the Base ID screen. See Figure 38-1.

6. Enter the three-digit BaseStation2 RTU ID number.

NOTE: The value shown in parenthesis indicates the current value.

7. Press to retain the value.

```
0 EXIT          3 CALLOUT TRIES  6 NO ACK
1 BASE ID      4 RADIO HOP
2 MODEM TYPE   5 NOTICE ON/OFF
BASE ID (999) > XXX
```

Figure 38-1

Modem Type (For Notice Option Callout only)

Use Modem Type to set the type of communication device being used by the control panel, either Radio or Phone. The factory default setting is RADIO.

To set the modem type, do the following.

1. Press , , , , , , , to display the Modem Type screen. See Figure 38-2.

2. Select the number associated with the type of communication device. See Figure 38-2.

- Press for RADIO. (Changes configure menu item number 4 to RADIO HOP).

or

- Press for PHONE. (Changes configure menu item number 4 to PHONE NUMBER).

NOTE: The value shown in parenthesis indicates the current value.

3. Press to retain the value.

```
0 EXIT          3 CALLOUT TRIES  6 NO ACK
1 BASE ID      4 RADIO HOP
2 MODEM TYPE   5 NOTICE ON/OFF
MODEM 0..RADIO 1..PHONE (0) > X
```

Figure 38-2

Constants/Com Port/Remote Control

Callout Tries (For Notice Option Callout only)

Use CALLOUT TRIES to set the number of callout tries the control panel makes to the BaseStation2 before abandoning the call and deleting the data. The factory default setting is 2.

To set the number of callout tries, follow these steps.

1. Press **SYSTEM**, **1**, **8**, **8**, **7**, **1**, **5**, **3** to display the Callout Tries screen. See Figure 39-1.
2. Enter the desired number of callout tries.

NOTE: The value shown in parenthesis indicates the current value.

3. Press **ENTER** to retain the value.

```
0 EXIT          3 CALLOUT TRIES  6 NO ACK
1 BASE ID      4 RADIO HOP
2 MODEM TYPE   5 NOTICE ON/OFF
CALLOUT TRIES ( 2) > X
```

Figure 39-1

Radio Hop (Notice Option Callout only)

If the Modem Type is set to Radio and the communication system uses an intermediate unit (radio) to pass data (hop) from the control panel on to the BaseStation2, use Radio Hop to setup the intermediate unit ID to be used by the control panel. NOTICE ON/OFF must be set to ON before using Radio Hop.

NOTE: Radio Hop is only displayed when the Modem Type is set to RADIO.

To setup the intermediate unit ID, do the following.

1. Press **SYSTEM**, **1**, **8**, **8**, **7**, **1**, **5**, **4** to display the Radio Hop screen. See Figure 39-2.
2. Press **1** for ON, or press **0** for OFF.

NOTE: The value shown in parenthesis indicates the current value.

3. Enter the three-digit intermediate unit ID number. See Figure 39-3.
4. Press **ENTER** to retain the value.

```
0 EXIT          3 CALLOUT TRIES  6 NO ACK
1 BASE ID      4 RADIO HOP
2 MODEM TYPE   5 NOTICE ON/OFF
RADIO HOP 1..ON 0..OFF (OFF) > X
```

Figure 39-2

```
0 EXIT          3 CALLOUT TRIES  6 NO ACK
1 BASE ID      4 RADIO HOP
2 MODEM TYPE   5 NOTICE ON/OFF
INTERMEDIATE UNIT ID (0) > XXX
```

Figure 39-3

Phone Number (Notice Option Callout only)

If the Modem Type is set to Phone, use the PHONE NUMBER to set up the BaseStation2 phone number to be used by the control panel.

To set the phone number, do the following.

1. Press **SYSTEM**, **1**, **8**, **8**, **7**, **1**, **5**, **4** to display the Phone screen. See Figure 39-4.
2. Enter the BaseStation2 phone number, without dashes, exactly as it needs to be dialed.

NOTE: The value shown in parenthesis indicates the current value.

3. Press **ENTER** to retain the value.

```
0 EXIT          3 CALLOUT TRIES  6 NO ACK
1 BASE ID      4 PHONE NUMBER
2 MODEM TYPE   5 NOTICE ON/OFF
PHONE (XXXXXXXXXX) > XXXXXXXXXXXX
```

Figure 39-4

System

Constants/Com Port/Remote Control

Notice On/Off (For Notice Option Callout only)

Notice On/Off is used to turn the real-time update function on or off. The factory default setting for NOTICE ON/OFF is OFF.

To turn the real-time update function on or off, do the following.

1. Press **SYSTEM**, **1**, **8**, **8**, **7**, **1**, **5**, **5** to display the Notice On/Off screen. See Figure 40-1.

NOTE: The value shown in parenthesis indicates the current value.

```
0 EXIT          3 CALLOUT TRIES  6 NO ACK
1 BASE ID      4 RADIO HOP
2 MODEM TYPE   5 NOTICE ON/OFF
NOTICE (OFF)  1..ON  2..OFF  >
```

Figure 40-1

2. Press **1** for ON or **0** for OFF.

No ACK

The No ACK function is for users who need to stop the machine if no acknowledgement is received from the base after a real-time update. CONTINUE TO RUN is the factory default setting.

To setup the No ACK, do the following.

1. Press **SYSTEM**, **1**, **8**, **8**, **7**, **1**, **5**, **6** to display the No ACK screen. See Figure 40-2.

2. Do one of the following.

- Press **1** to allow the machine to Continue To Run.
- Press **2** to Shut Down the machine if no acknowledgement has been received from the base.

```
0 EXIT          3 CALLOUT TRIES  6 NO ACK
1 BASE ID      4 RADIO HOP
2 MODEM TYPE   5 NOTICE ON/OFF
1..CONTINUE TO RUN  2..SHUTDOWN (1) > X
```

Figure 40-2

Service Tool

To set the SERVICE TOOL protocol, do the following.

1. Press **SYSTEM**, **1**, **8**, **8**, **7**, **2**, **1** to display the Com Port protocol screen. See Figure 40-3.

2. Press **2** for SERVICE TOOL.

```
0 EXIT          3 PLC          6 GPS V1
1 REMOTE CTL    4 NA           7 NONE
2 SERVICE TOOL  5 REMOTE CTL V2
SELECT PROTOCOL (2) >
```

Figure 40-3

PLC

PLC (Power Line Carriers) is used to set the GPS V2, Tire Pressure, VRI-Zone, Water Pressure (End Pressure) and PLC wide boundary protocols.

1. Press **SYSTEM**, **1**, **8**, **8**, **7**, **2**, **1**, **3** for PLC. See Figure 40-4.

```
POWER LINE CARRIER OPTIONS          *=ON
1*GPS V2          3 VRI-ZONE          5 PLC WIDE BND
2 TIRE PRES      4 WATER PRES
PRESS NUMBER TO TOGGLE >
```

Figure 40-4

GPS V2

GPS V2 is used to set protocol for the GPS Position option. The power line carriers must be running version 2 software. Position Loss constants are used to control the machine if GPS signal loss occurs.

1. Press **SYSTEM**, **1**, **8**, **8**, **7**, **2**, **1**, **3** for PLC.

2. Press **1** to enable GPS V2. See Figure 40-5.

```
POWER LINE CARRIER OPTIONS          *=ON
1*GPS V2          3 VRI-ZONE          5 PLC WIDE BND
2 TIRE PRES      4 WATER PRES
PRESS NUMBER TO TOGGLE >
```

Figure 40-5

Constants/Com Port/PLC

Tire Pressure

TIRE PRES is used to set the protocol for the Tire Pressure Monitor option. Constants for Tire Pressure Monitor are set on the Tire Pressure Monitor screen.

1. Press **SYSTEM**, **1**, **8**, **8**, **7**, **2**, **1**, **3** for PLC. See Figure 41-1.
2. Press **2** to enable TIRE PRES. See Figure 41-2.

```

0 EXIT          3 PLC          6 GPS V1
1 REMOTE CTL    4 NA          7 NONE
2 SERVICE TOOL  5 REMOTE CTL V2
SELECT PROTOCOL (3) >
    
```

Figure 41-1

VRI-Zone

VRI-ZONE is used to set the protocol for the VRI-ZONE option. The protocol must be set prior to turning on the variable application on the OPTIONS screen.

1. Press **SYSTEM**, **1**, **8**, **8**, **7**, **2**, **1**, **3** for PLC.
2. Press **3** to enable VRI-Zone. See Figure 41-3.
3. If GPS is used, also select **1** for GPS V2.

```

POWER LINE CARRIER OPTIONS      *=ON
1 GPS V2      3 VRI-ZONE    5 PLC WIDE BND
2*TIRE PRES  4 WATER PRES
PRESS NUMBER TO TOGGLE >
    
```

Figure 41-2

Water Pressure Monitor

WATER PRES is used to set the protocol for the Water Pressure option. Constants for Water Pressure Monitor are set on the Water Pressure Monitor screen.

1. Press **SYSTEM**, **1**, **8**, **8**, **7**, **2**, **1**, **3** for PLC.
2. Press **4** to enable WATER PRES. See Figure 41-4.

```

POWER LINE CARRIER OPTIONS      *=ON
1 GPS V2      3*VRI-ZONE    5 PLC WIDE BND
2 TIRE PRES  4 WATER PRES
PRESS NUMBER TO TOGGLE >
    
```

Figure 41-3

PLC Wide Boundary

PLC WIDE BND is used to set the protocol for the PLC Wide Boundary and GPS Position option.

1. Press **SYSTEM**, **1**, **8**, **8**, **7**, **2**, **1**, **3** for PLC.
2. Press **5** to enable the Wide Boundary protocol. See Figure 41-5.
3. The next available tower box ID is displayed.
 - A different ID number can be entered. However if VRI-Zone is enabled, the ID number cannot be changed. Record Wide Boundary Tower Box ID _____
4. Press **ENTER** to accept or save the ID number.
5. For GPS only, press **1** to enable GPS position protocol.
 - If necessary, change the ID number to match the Wide Boundary tower box ID.
 - Press **ENTER** to accept or save the ID number.
6. Press **SYSTEM** to go back to the Status screen.

```

POWER LINE CARRIER OPTIONS      *=ON
1 GPS V2      3 VRI-ZONE    5 PLC WIDE BND
2 TIRE PRES  4*WATER PRES
PRESS NUMBER TO TOGGLE >
    
```

Figure 41-4

```

POWER LINE CARRIER OPTIONS      *=ON
1 GPS V2      3 VRI-ZONE    5*PLC WIDE BND
2 TIRE PRES  4 WATER PRES
PRESS NUMBER TO TOGGLE >
    
```

Figure 41-5

System

Constants/Com Port/PLC

Remote Control V2

Remote Control V2 is reserved for future applications.

GPS V1

GPS V1 is used to set the protocol for the GPS Position option. The power line carriers must be running Version 1 software. Position Loss constants are used to control the machine if GPS signal loss occurs.

1. Press **SYSTEM**, **1**, **8**, **8**, **7**, **2** for 25-PIN COM PORT.
2. Press **1**, **6** for GPS V1. See Figure 42-1.

0 EXIT	3 PLC	6 GPS V1
1 REMOTE CTL	4 NA	7 NONE
2 SERVICE TOOL	5 REMOTE CTL V2	
SELECT PROTOCOL (6) >		

Figure 42-1

None

The None function is reserved for future applications. See Figure 42-2.

0 EXIT	3 PLC	6 GPS V1
1 REMOTE CTL	4 NA	7 NONE
2 SERVICE TOOL	5 REMOTE CTL V2	
SELECT PROTOCOL (7) >		

Figure 42-2

Constants

Pres Cal

PRES CAL is used to calibrate the pressure transducer to the current water pressure reading of zero when the pump is off and the machine is dry.

Setting Pres Cal

To calibrate the pressure transducer to zero, follow these steps.

1. Make sure the pump is off and the machine is dry.
2. Press **SYSTEM**, **1**, **8**, **8**, **8**, **1** to display the Pressure Calibration screen. See Figure 43-1.
3. Press **1** PRES CAL to calibrate pressure, or press **0** to CANCEL.

```

0 EXIT          3 BACKLIGHT  6 TIRE PRES
1 PRES CAL     4 CRUISE CTL 7 END PRES
2 PRES TYPE   5 VRI-ZONE   8 OTHER
0 CANCEL 1 CALIBRATE >
    
```

Figure 43-1

Pres Type

PRES TYPE is used to set the type of pressure sensor being used on the machine. The pressure sensor is factory set to RATIOMETRIC. There are three pressure sensor settings available:

- RATIOMETRIC - for pressure transducer. (Select.)
- ABSOLUTE - for pressure transducer.
- PRESSURE SWITCH - for mechanical pressure switch.

NOTE

When the pressure switch is selected:

- Transducer-related error codes do not appear on the status screen.
- The status screen displays **LOW** or **OK** instead of a pressure value.

Setting Pres Type

To set the pressure sensor type, follow these steps.

1. Press **SYSTEM**, **1**, **8**, **8**, **8**, **2** to display the Pressure Sensor screen. See Figure 43-2.
2. Select the type of pressure sensor being used.
 - 1** = RATIOMETRIC
 - 2** = ABSOLUTE
 - 3** = PRESSURE SWITCH

```

0 EXIT          3 PRESSURE SWITCH
1 RATIOMETRIC
2 ABSOLUTE
PRESSURE SENSOR TYPE (1) >
    
```

Figure 43-2

NOTE: The value shown in parenthesis indicates the current value.

Backlight

Backlight is used to set the Backlight Delay time. The backlight shuts off after the selected number of minutes without activity on the key pad. The Backlight Delay is factory set to 1 minute.

Setting Backlight

To set the backlight delay, follow these steps.

1. Press **SYSTEM**, **1**, **8**, **8**, **8**, **3** to display the backlight delay screen. See Figure 43-3.
2. Enter the desired delay time in minutes.
3. Press **ENTER** to retain the value.

```

0 EXIT          3 BACKLIGHT  6 TIRE PRES
1 PRES CAL     4 CRUISE CTL 7 END PRES
2 PRES TYPE   5 VRI-ZONE   8 OTHER
BACKLIGHT DLY IN MINUTES ( 1) >
    
```

Figure 43-3

System

Constants

Cruise Control

The Cruise Control screen is used to view and change the Max % Change Of Speed, Field Size In Degrees, and Resolution constants.

Press **SYSTEM**, **1**, **8**, **8**, **8**, **4** to display the cruise control screen. See Figure 44-1.

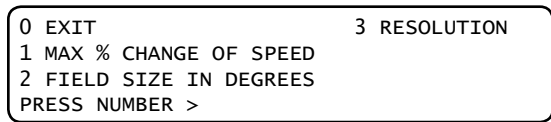

Figure 44-1

Max % Change Of Speed

Max % Change Of Speed is used to view and change the maximum percentage change of speed. This value is the maximum percentage of change in speed that Cruise Control is allowed to make. The default setting is 10%. The range is 0% to 255%. When set to 0%, Cruise Control is not allowed to change the speed. When set to 255%, Cruise Control is allowed to change 255% of the set % timer setting.

For example, if the Percent Timer is set to 20% and the Max % Change Of Speed is set to 50%, then Cruise Control can adjust the Percent Timer in a range from 10%-30%.

1. Press **SYSTEM**, **1**, **8**, **8**, **8**, **4**, **1** for the Maximum Percentage Change Of Speed screen (Max % Change Of Speed). See Figure 44-2.
2. To change the maximum percentage change of speed, enter a percentage from 0 to 255.
3. Press **ENTER**.

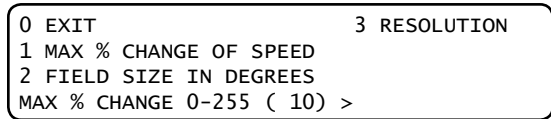

Figure 44-2

Field Size In Degrees

Field Size In Degrees is used to view and change the field size. This value is the field size in degrees, and assumes that the field always starts at 0 degrees. The default is 360 degrees. The range is 15 to 360 degrees.

1. Press **SYSTEM**, **1**, **8**, **8**, **8**, **4**, **2** for the Field Size In Degrees screen. See Figure 44-3.
2. Enter a degree from 15 to 360.
3. Press **ENTER**.

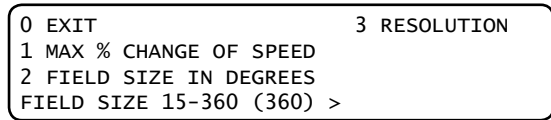

Figure 44-3

Resolution

Resolution is used to view and adjust the speed of the machine. This value is the number of degrees that the control panel uses to measure time per resolution. The default setting is 5 degrees. The settings are 1, 5, 10 and 15 degrees.

1. Press **SYSTEM**, **1**, **8**, **8**, **8**, **4**, **3** for the Resolution screen. See Figure 44-4.
2. To change the resolution, press one of the following.

3 = 15 degree

2 = 10 degree

1 = 5 degree*

0 = 1 degree*

* Not recommended for a resolver-based position.

3. Press **ENTER** to retain the value.

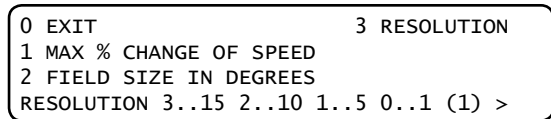

Figure 44-4

Constants

VRI-Zone

Use the VRI-Zone screen to set the Min Cycle Time, Min Flow Rate, Max Pres, Valve Resync, and Sprinkler Banks constants.

- Press **SYSTEM**, **1**, **8**, **8**, **8**, **5** for the VRI-Zone screen. See Figure 45-1.

```
0 EXIT                3 MAX PRES
1 MIN CYCLE TIME     4 VALVE RESYNC
2 MIN FLOW RATE      5 SPRINKLER BANKS
PRESS NUMBER >
```

Figure 45-1

Minimum Cycle Time

MIN CYCLE TIME is used to view and change the sprinkler zone minimum valve cycle time.

- Press **SYSTEM**, **1**, **8**, **8**, **8**, **5**, **1** for the Minimum Valve Cycle Time screen. See Figure 45-2.
- Do one of the following to search the screen:
 - Press **FORWARD** to view the next sprinkler zone and cycle time.
 - Press **REVERSE** to view the previous sprinkler zone and cycle time.

```
PRESS ENTER..SAVE REV..BACK FOR..NEXT
1:999  3:888  5:555  7:333  9:222
2:888  4:777  6:444  8:333  10:111
PRESS #..BANK MIN CYCLE TIME >
```

Figure 45-2

When reading the screen, the first number is the sprinkler zone, and the last number is the minimum valve cycle time. See Figure 45-3 and 45-4.

- To change the minimum valve cycle time for a sprinkler zone press the number of the zone and then press **ENTER**. See Figures 45-5.

```
PRESS ENTER..SAVE REV..BACK FOR..NEXT
3:888  5:555  7:333  9:222  11:99
4:777  6:444  8:333  10:111  12:88
PRESS #..BANK MIN CYCLE TIME >
```

Figure 45-3

For example, press **3**, **0** and **ENTER** to display the minimum cycle time for zone 30.

```
PRESS ENTER..SAVE REV..BACK FOR..NEXT
21:50  23:40  25:30  27:20  29:10
22:45  24:35  26:25  28:15  30:5
PRESS #..BANK MIN CYCLE TIME >
```

Figure 45-4

The minimum cycle for the selected zone is shown () in seconds.

- If desired, enter a minimum cycle time value and then press **ENTER**.

```
PRESS ENTER..SAVE REV..BACK FOR..NEXT
21:50  23:40  25:30  27:20  29:10
22:45  24:35  26:25  28:15  30:5
MIN CYCLE RATE IN SECONDS (5) >
```

Figure 45-5

The range is 1-999 seconds. The default is 20 seconds.

Minimum Flow Rate

MIN FLOW RATE is used to monitor the flow rate, and requires the use of an optional flow meter.

A Low Flow error is recorded if the flow rate reaches the minimum flow rate setting while the system is above the low pressure setting. If the flow rate remains at or below the low flow rate setting for 15 seconds, the machine is shut down and a Low Flow system fault is recorded. A Low Flow system fault can only occur if the system is above the low pressure setting, the minimum flow rate feature is on, and a flow meter is installed.

- Press **SYSTEM**, **1**, **8**, **8**, **8**, **5**, **2** for the Minimum Flow Rate Screen. See Figure 45-6.

The current minimum flow rate is shown () in gpm (lpm).

```
0 EXIT                3 MAX PRES
1 MIN CYCLE TIME     4 VALVE RESYNC
2 MIN FLOW RATE      5 SPRINKLER BANKS
ENTER MINIMUM FLOW RATE GPM ( 0 ) >
```

Figure 45-6

- If desired, enter a new minimum flow rate value and press **ENTER**.

The range is 1-999 gpm (lpm). When set to 0 (zero) the low flow system fault is disabled. The default is 0.

System

Constants

VRI-Zone

Maximum Pressure

MAX PRES is used to monitor the water pressure. A High Pressure error is recorded if the water pressure reaches the maximum pressure setting. If the water pressure remains at the maximum pressure setting for three seconds, the machine is shut down and a High Pressure fault is recorded.

1. Press **SYSTEM**, **1**, **8**, **8**, **8**, **5**, **3** for the Maximum Pressure screen (max pres). See Figure 46-1.

The current maximum pressure is shown () in psi (kPa).

2. If desired, enter a new Maximum Pressure value, and press **ENTER**.

The range is 1-999 psi (kPa). The default is 80 psi (551.5 kPa).

```
0 EXIT                3 MAX PRES
1 MIN CYCLE TIME     4 VALVE RESYNC
2 MIN FLOW RATE      5 SPRINKLER BANKS
ENTER MAXIMUM PRESSURE (80) >
```

Figure 46-1

Valve Resync

VALVE RESYNC is used to monitor water pressure, and re-synchronizes the duty cycle of all sprinkler zones. When the valve resynchronize pressure is reached, the duty cycles of all sprinkler zones start over. All the odd numbered zones start on the OFF part of the cycle, and all even numbered zones start on the ON part of the cycle.

1. Press **SYSTEM**, **1**, **8**, **8**, **8**, **5**, **4** for VALVE RESYNC. See Figure 46-2.

The current resync pressure is shown () in psi (kPa).

2. If desired, enter a new resync pressure value and press **ENTER**.

The range is 1-999 psi (6.90-6887.90 kPa). The default is 60 psi (413.7 kPa).

```
0 EXIT                3 MAX PRES
1 MIN CYCLE TIME     4 VALVE RESYNC
2 MIN FLOW RATE      5 SPRINKLER BANKS
ENTER RESYNC PRESSURE (60) >
```

Figure 46-2

Sprinkler Banks

SPRINKLER BANKS is used to set the number of sprinkler zones. This is required so that the control panel knows how many tower boxes it must talk to. For example, If there are 13 sprinkler zones, then the control panel talks to tower boxes with an ID from 1-7.

1. Press **SYSTEM**, **1**, **8**, **8**, **8**, **5**, **5** for SPRINKLER BANKS. See Figure 46-3.

The current number of sprinkler zones is shown in parenthesis.

2. Enter the number of sprinkler zones for this application, and press **ENTER**.

The range is 1-30 sprinkler zones. The default is 1.

```
0 EXIT                3 MAX PRES
1 MIN CYCLE TIME     4 VALVE RESYNC
2 MIN FLOW RATE      5 SPRINKLER BANKS
ENTER # OF SPRINKLER BANKS (30) >
```

Figure 46-3

Constants

Tire Pressure Monitor Screen

TIRE PRES is used to access the Tire Pressure Monitor Screen (TPMS) to set the following constants:

- Sensor Setup
- Warn Pressure Drop
- Shutdown Pressure Drop

Press **SYSTEM**, **1**, **8**, **8**, **8**, **6** for the Tire Pressure Monitor screen. See Figure 47-1.

Sensor Setup

1. Press **SYSTEM**, **1**, **8**, **8**, **8**, **6**, **1** for SENSOR SETUP. See Figure 47-2.

2. Select the pivot tower number. Use the up/down arrows to select the pivot tower number to set up. Tower 1 is the tower closest to the pivot point. The range is 1-18. See Figure 47-3.

3. After selecting the pivot tower, press **1** for NOMINAL PRESSURE.

4. Enter the recommended inflation pressure value for the tires on this tower. The default is 18 psi (124 kPa) and range is 6 psi (41 kPa) to 37 psi (255 kPa). See Figure 47-4.

5. Press **ENTER**.

6. Press **2** for TPMS ID. See Figure 47-5.

7. Enter the TPMS tower box ID that receives signals from pressure sensors on this tower.

Use the number key pad to enter 0-9. To enter A-F, use the following keys.

- Start Key = A
- Stop Key = B
- Forward = C
- Reverse = D
- Water ON = E
- Water OFF = F.

The default ID is 0, and the range is 0-9 and A-F, where A = 10, B = 11, C = 12, D = 13, E = 14, and F = 15.

8. Press **ENTER**.

9. Press **3** for SENSOR ID. See Figure 47-6.

10. Enter the number of tires on this tower.

The default number of tires is 2, and the range is 2 - 4.

```
0 EXIT          3 BACKLIGHT  6 TIRE PRES
1 PRES CAL     4 CRUISE CTL 7 END PRES
2 PRES TYPE    5 VRI-ZONE   8 OTHER
PRESS NUMBER >
```

Figure 47-1

```
0 EXIT          3 SHUTDOWN PRES DROP
1 SENSOR SETUP
2 WARN PRES DROP
PRESS NUMBER >
```

Figure 47-2

```
PIVOT TOWER 1          PRESS ESC TO EXIT
0 EXIT                2 TPMS ID
1 NOMINAL PRES       3 SENSOR ID
PRESS #, OR UP/DOWN TO CHANGE TOWER >
```

Figure 47-3

```
PIVOT TOWER 1          PRESS ESC TO EXIT
0 EXIT                2 TPMS ID
1 NORMAL PRES        3 SENSOR ID
NOMINAL PRESSURE (18) >
```

Figure 47-4

```
PIVOT TOWER 1          PRESS ESC TO EXIT
0 EXIT                2 TPMS ID
1 NORMAL PRES        3 SENSOR ID
TPMS ID 0-F (0) >
```

Figure 47-5

```
PIVOT TOWER 1          PRESS ESC TO EXIT
0 EXIT                2 TPMS ID
1 NORMAL PRES        3 SENSOR ID
NUMBER OF TIRES 2-4 (2) >
```

Figure 47-6

System

Constants/Tire Pressure Monitor Screen Sensor Setup (continued)

11. Press .
12. Enter the six-digit tire sensor ID for the number of tires selected. See Figure 48-1.
 - Two tires - Enter reverse tire sensor ID and forward tire sensor ID
 - Three tires - Enter reverse tire sensor ID, mid tires sensor ID, and forward tire sensor ID
 - Four tires - Enter reverse tire sensor ID, mid reverse tire sensor ID, mid forward tire sensor ID and forward tire sensor ID.
13. Press after each sensor ID entry.
14. Press to exit screen.

Warn Pres Drop

1. Press , , , , , , for WARN PRES DROP. See Figure 48-2.
2. Enter the desired pressure value for the Pressure Drop warning.

The default is 4 psi (27 kPa), and the range is 1 psi (6 kPa) to 15 psi (103 kPa). See Figure 48-3.
3. Press .

Shutdown Pres Drop

1. Press , , , , , , for SHUTDOWN PRES DROP. See Figure 48-4.
2. Press to turn Tire Shutdown ON, or press to turn it OFF. The system default is OFF.
3. If SHUTDOWN PRES DROP is turned ON, enter the desired pressure value for the pressure drop shutdown.

The default is 6 psi (41 kPa) and range is 1 psi (6 kPa) to 15 psi (103 kPa). See Figure 48-5.
4. Press .

```
PIVOT TOWER 1          PRESS ESC TO EXIT
0 EXIT                2 TPMS ID
1 NORMAL PRES        3 SENSOR ID
REV TIRE SENSOR ID (000000) >
```

Figure 48-1

```
0 EXIT                3 SHUTDOWN PRES DROP
1 SENSOR SETUP
2 WARN PRES DROP
PRESS NUMBER >
```

Figure 48-2

```
0 EXIT                3 SHUTDOWN PRES DROP
1 SENSOR SETUP
2 WARN PRES DROP
PRESSURE DROP - WARNING (4) >
```

Figure 48-3

```
0 EXIT                3 SHUTDOWN PRES DROP
1 SENSOR SETUP
2 WARN PRES DROP
TIRE SHUTDOWN 1..ON 0..OFF (OFF) >
```

Figure 48-4

```
0 EXIT                3 SHUTDOWN PRES DROP
1 SENSOR SETUP
2 WARN PRES DROP
PRESSURE DROP - SHUTDOWN (6) >
```

Figure 48-5

Constants

End Water Pressure Monitor

END PRES is used to access the End Water Pressure Monitor Screen to view or change the TPMS and Sensor ID numbers for the end water pressure monitor.

1. Press **SYSTEM**, **1**, **8**, **8**, **8**, **7** for END PRES. See Figure 49-1.
2. Press **1** for TPMS ID. See Figure 49-2.
3. Enter the TPMS receiver ID that receives signals from end water pressure sensor.

Use the number key pad to enter 0-9. To enter A-F, use the following keys.

- Start Key = A
- Stop Key = B
- Forward = C
- Reverse = D
- Water ON = E
- Water OFF = F.

The default ID is 0, and the range is 0-9 and A-F,, where A=10, B=11, C=12, D=13, E=14 and F=15.

4. Press **ENTER**.
5. Press **2** for SENSOR ID. See Figure 49-3.
6. Enter the six-digit Water Pressure Sensor ID. See Figure 49-4
7. Press **ENTER**.

System Status Screen

The water pressure readout on the System screen flashes between pivot point pressure and end of machine pressure every two seconds, when recent data is available. When old or no data is available, only the pivot point water pressure is shown. See Figure 49-5.

- Recent Data is less than, or equal to five minutes old.
- An Asterisk (*) next to the water pressure reading indicates end of machine pressure.

Watering Timer

WATERING TIMER provides separate timers for over-watering and under-watering conditions, and is used to monitor and control both.

The Watering Timer feature is available for use with either GPS or Resolver.

Press **SYSTEM**, **1**, **8**, **8**, **8**, **8**, **1** to view the Watering Timer screen. See Figure 49-6.

```

0 EXIT          3 BACKLIGHT  6 TIRE PRES
1 PRES CAL     4 CRUISE CTL  7 END PRES
2 PRES TYPE    5 VRI-ZONE   8 OTHER
PRESS NUMBER>
    
```

Figure 49-1

```

0 EXIT
1 TPMS ID
2 SENSOR ID
PRESS NUMBER >
    
```

Figure 49-2

```

0 EXIT
1 TPMS ID
2 SENSOR ID
TPMS ID 0-F (0) >
    
```

Figure 49-3

```

0 EXIT
1 TPMS ID
2 SENSOR ID
END PRES SENSOR ID (000000) >
    
```

Figure 49-4

```

10:05:38      Pivot Point  90.7 DEG WAITING
01/13/10      (37. PSI) REVERSE
477 VOLTS      95.0 % WATER. ON
25.4 HR        0.26 IN SIS= 90.5
    
```

```

10:05:38      End of Machine  90.7 DEG WAITING
01/13/10      (25. *PSI) REVERSE
477 VOLTS      95.0 % WATER. ON
25.4 HR        0.26 IN SIS= 90.5
    
```

Figure 49-5 Main Screen

```

0 EXIT          3 RAIN
1 WATERING TIMER
2 TEMPERATURE
PRESS NUMBER > 1
    
```

Figure 49-6

System

Constants

Watering Timer (continued)

WT On/Off

1. To turn the Watering Timer (WT) ON or OFF, press **1**. See Figure 50-1.

NOTE: The Watering Timer functions only when the machine is running with water on, and after the Startup Pressure Delay time period.

2. Press either **1** ON or **0** OFF. The default setting is OFF. See Figure 50-2.

WT Status

1. To view the status of the watering timers, press **2**. The following is displayed. See Figure 50-3.
 - RUN TIMER - Time machine has run without moving. The Percent Timer must be ON for this to work. It is reset every 0.1°, or with a change in direction.
 - SHUTDOWN - Time at which the machine is shut down because of lack of movement.
 - TIMER - Calculated time for machine to travel 5° at 100%.
 - ERROR - Actual travel time, if faster than calculated time. Then, an underwatering error is logged.
 - POSITION - GPS position of machine in field.

% Overwater Shutdown

% Overwater Shutdown allows the irrigation system to be shut down if the machine is moving too slowly, thereby applying too much water to all, or parts of the field.

The Overwatering Timer (OWT) resets every tenth of a degree (0.1°) of movement, and with a change in direction. It only increments if the Percentage Timer output is on, and after the Startup Pressure Delay time period.

1. To set the % Overwater Shutdown, press **3**. See Figure 50-4.
2. Enter the Overwater Shutdown number of minutes. Default is 100. Range is 3.4 to 102.4. See Figure 50-5.

```
0 EXIT          3 % OVERWATER SHUTDOWN
1 WT ON/OFF    4 % UNDERWATER ERROR
2 WT STATUS
PRESS NUMBER > 1
```

Figure 50-1

```
0 EXIT          3 % OVERWATER SHUTDOWN
1 WT ON/OFF    4 % UNDERWATER ERROR
2 WT STATUS
WATERING TIMER ( ON) 1..ON 0..OFF >
```

Figure 50-2

```
          OWT @ 100%          UWT @ 100% 5DEG
RUN TIMER: 2.4 MIN.    TIMER: 6.5 MIN.
SHUTDOWN: 6.0 MIN.    ERROR: 3.7 MIN.
PRESS ANY KEY >          POSITION: 179.5
```

Figure 50-3

```
0 EXIT          3 % OVERWATER SHUTDOWN
1 WT ON/OFF    4 % UNDERWATER ERROR
2 WT STATUS
PRESS NUMBER > 3
```

Figure 50-4

```
0 EXIT          3 % OVERWATER SHUTDOWN
1 WT ON/OFF    4 % UNDERWATER ERROR
2 WT STATUS
% OVERWATER SHUTDOWN (100) >
```

Figure 50-5

Constants

Watering Timer (continued)

% Underwater Error

% Underwater Error creates an error if the irrigation system is moving faster than it should, thereby applying less water to all, or parts of the field.

The Underwatering Timer (UWT) resets every five degrees (5°) of movement, and with a change in direction. It only increments if the Percentage Timer output is ON, and after the Startup Pressure Delay time period.

1. To set the % Underwater Error, press **4**. See Figure 51-1.
2. Enter the UNDERWATER ERROR number of minutes. Default is 50. See Figure 51-2.

```
0 EXIT          3 % OVERWATER SHUTDOWN
1 WT ON/OFF    4 % UNDERWATER ERROR
2 WT STATUS
PRESS NUMBER > 4
```

Figure 51-1

```
0 EXIT          3 % OVERWATER SHUTDOWN
1 WT ON/OFF    4 % UNDERWATER ERROR
2 WT STATUS
% UNDERWATER ERROR ( 50) >
```

Figure 51-2

System

Constants

Temperature

The Temperature function allows the user to set the temperature below which the irrigation system is shut down. If the low temperature function is on, and the temperature goes below the low temperature limit, the machine stops and a Temperature fault is logged in the system.

Temperature Shutdown

1. Press **SYSTEM**, **1**, **8**, **8**, **8**, **8**, **2** for TEMPERATURE. See Figure 52-1.
2. Press **1** for TEMP SHUTDOWN. See Figure 52-2.
3. Press **1** to turn the temperature shutdown function ON, and **0** to turn it OFF. The default value is OFF. See Figure 52-3.

Low Temp Limit

1. To set the low temperature limit, press **2** LOW TEMP LIMIT. See Figure 52-4.
2. Press the appropriate keys to enter the temperature. Ex: **3**, **8** for 38. See Figure 52-5.

The default value is 41°F (5°C). The minimum value is 14°F (-10°C), and the maximum value is 176°F (80°C).

Current Temp

Press **3** CURRENT TEMP to view the current temperature. See Figure 52-6

The temperature is displayed as + or - degrees Fahrenheit (F) or Celsius (C), depending on if English or Metric units have been enabled. See Figure 52-7.

Sensor Setup

1. Press **4** SENSOR SETUP to set up the air temperature sensor. See Figure 52-8.
2. Press the appropriate keys to enter the temperature coefficient. Ex: **1**, **7**, **.**, **7**, **8** for 17.78. Valid values are 0.00 - 99.9 mV/°C. See Figure 52-9.

If you are using the air temperature sensor provided with the Pro2, its temperature coefficient has already been set up on the control panel. It is displayed as the default value (17.78) for SENSOR SETUP.

If you are using an air temperature sensor other than the one provided, it must be calibrated to work with the Pro2. Refer to its manufacturer's specifications for the temperature coefficient.

3. Press the appropriate keys to enter the temperature offset. Ex: **-**, **1**, **8** for -18. Valid values are -500 - +500. The default value is -18. See Figure 52-10.

```
0 EXIT                3 RAIN
1 WATERING TIMER
2 TEMPERATURE
PRESS NUMBER > 2
```

Figure 52-1

```
0 EXIT                3 CURRENT TEMP
1 TEMP SHUTDOWN      4 SENSOR SETUP
2 LOW TEMP LIMIT
PRESS NUMBER > 1
```

Figure 52-2

```
0 EXIT                3 CURRENT TEMP
1 TEMP SHUTDOWN      4 SENSOR SETUP
2 LOW TEMP LIMIT
TEMP SHUTDOWN (OFF) 1..ON 0..OFF >
```

Figure 52-3

```
0 EXIT                3 CURRENT TEMP
1 TEMP SHUTDOWN      4 SENSOR SETUP
2 LOW TEMP LIMIT
PRESS NUMBER >
```

Figure 52-4

```
0 EXIT                3 CURRENT TEMP
1 TEMP SHUTDOWN      4 SENSOR SETUP
2 LOW TEMP LIMIT
LOW TEMP LIMIT ( 41) > 38
```

Figure 52-5

```
0 EXIT                3 CURRENT TEMP
1 TEMP SHUTDOWN      4 SENSOR SETUP
2 LOW TEMP LIMIT
PRESS NUMBER >
```

Figure 52-6

```
0 EXIT                3 CURRENT TEMP
1 TEMP SHUTDOWN      4 SENSOR SETUP
2 LOW TEMP LIMIT
CURRENT TEMPERATURE + 77 F
```

Figure 52-7

```
0 EXIT                3 CURRENT TEMP
1 TEMP SHUTDOWN      4 SENSOR SETUP
2 LOW TEMP LIMIT
PRESS NUMBER >
```

Figure 52-8

```
0 EXIT                3 CURRENT TEMP
1 TEMP SHUTDOWN      4 SENSOR SETUP
2 LOW TEMP LIMIT
TEMP COEFFICIENT (17.78) MV/C >
```

Figure 52-9

```
0 EXIT                3 CURRENT TEMP
1 TEMP SHUTDOWN      4 SENSOR SETUP
2 LOW TEMP LIMIT
TEMPERATURE OFFSET (- 18) C >
```

Figure 52-10

Constants

Rain

The Rain function allows the user to set the amount of rainfall above which the irrigation system is shut down. If the Rain Shutdown function is on, and the total rainfall in the defined window of time goes rain shutdown limit, the machine stops and a Rain fault is logged in the system.

Rain Shutdown

1. Press **SYSTEM**, **1**, **8**, **8**, **8**, **8**, **3** for RAIN. See Figure 53-1.
2. Press **1** for RAIN SHUTDOWN. See Figure 53-2.
3. Press **1** to turn the rain shutdown function ON, and **0** to turn it OFF. The default value is ON. See Figure 53-3.

Rain Limit

1. To set the rain limit, press **2** RAIN LIMIT. See Figure 53-4.
2. Press the appropriate keys to enter the number of inches. Ex: **1**, **.**, **5**, **0** for 1.50. See Figure 53-5.

The default value is 1.00 inch (25.4 mm). The rainfall is entered and displayed in inches or millimeters, depending on if English or Metric units have been enabled.

Rain Window

1. To set the number of days during which the total rainfall is calculated for use with Rain Shutdown, press **3** RAIN WINDOW. See Figure 53-6.
2. Use the appropriate keys to enter the number of days (0 - 10). See Figure 53-7.
 - Enter 0 days to calculate the amount from midnight to the current time.
 - Enter 1 day to calculate the amount from all of yesterday plus the accumulation from midnight to the current time.
 - A 10-day rainfall history is stored in the system.

```
0 EXIT                3 RAIN
1 WATERING TIMER
2 TEMPERATURE
PRESS NUMBER > 3
```

Figure 53-1

```
0 EXIT                3 RAIN WINDOW
1 RAIN SHUTDOWN      4 SENSOR SETUP
2 RAIN LIMIT
PRESS NUMBER > 1
```

Figure 53-2

```
0 EXIT                3 RAIN WINDOW
1 RAIN SHUTDOWN      4 SENSOR SETUP
2 RAIN LIMIT
RAIN SHUTDOWN ( ON) 1..ON 0..OFF >
```

Figure 53-3

```
0 EXIT                3 RAIN WINDOW
1 RAIN SHUTDOWN      4 SENSOR SETUP
2 RAIN LIMIT
PRESS NUMBER > 2
```

Figure 53-4

```
0 EXIT                3 RAIN WINDOW
1 RAIN SHUTDOWN      4 SENSOR SETUP
2 RAIN LIMIT
RAIN SHUTDOWN LIMIT (1.00) >
```

Figure 53-5

```
0 EXIT                3 RAIN WINDOW
1 RAIN SHUTDOWN      4 SENSOR SETUP
2 RAIN LIMIT
PRESS NUMBER > 3
```

Figure 53-6

```
0 EXIT                3 RAIN WINDOW
1 RAIN SHUTDOWN      4 SENSOR SETUP
2 RAIN LIMIT
RAIN WINDOW 0-10 DAYS ( 1) >
```

Figure 53-7

System

Constants

Rain (continued)

Sensor Setup

1. Press **4** SENSOR SETUP to calibrate the rain sensor. See Figure 54-1.
2. Press the appropriate keys to enter the Rain Coefficient Inches per Pulse (Rain Coefficient In/Pulse).

Ex: **0**, **.**, **0**, **1**, **0** for 0.010. See Figure 54-2.

Most rainfall sensors are calibrated at 0.010 (factory default). Refer to the manufacturer's specifications for the Rainfall Coefficient Inches per Pulse for your sensor.

```
0 EXIT                3 CURRENT TEMP
1 TEMP SHUTDOWN      4 SENSOR SETUP
2 LOW TEMP LIMIT
PRESS NUMBER > 4
```

Figure 54-1

```
0 EXIT                3 CURRENT TEMP
1 TEMP SHUTDOWN      4 SENSOR SETUP
2 LOW TEMP LIMIT
RAIN COEFFICIENT IN/PULSE (0.010)>
```

Figure 54-2

Data

Data is used to review machine information collected by the control panel. See Figure 55-1. There are eight data types available:

- A/D - Review analog to digital voltages for troubleshooting.
- PULSE - Review electrical pulse counters and rates.
- MODULES - Review the status of selected relays. A relay is considered a module.
- FLOW/WIND/TEMP - Review the total flow volume and rate of flow when the flow meter option is installed. Review wind speed when the wind meter option is installed. Review the temperature when the temperature sensor option is installed.
- WATER PRESS - Review the end water pressure readings when the end water pressure sensor option is installed.
- COUNT - Review and set counter readings 0 through 4.
- TIRE PRESS - Review the tire pressure readings when the tire pressure sensor option is installed.
- RAIN - Review the rainfall amount for the current day and each of the previous 10 days, when the rainfall sensor option is installed.

0 EXIT	3 MODULES	6 COUNT
1 A/D	4 FLOW/WIND/TEMP	7 NA
2 PULSE	5 NA	8 RAIN
PRESS NUMBER >		

Figure 55-1

A/D - Analog to Digital Voltages

A/D is used to review analog voltages. There are twelve analog channels, numbered 0 through 11, to monitor voltage feedback:

- Channels 0 and 1 monitor two voltage signals from the resolver located in the collector ring. These voltages change as the pivot moves, and are used to calculate the position of the pivot in degrees. The voltage readings should be between 0 and 5000 mV.
- Channel 2 (AD2) monitors voltage from the temperature sensor. This value varies, as the temperature increases and decreases, between 0 and 5 volts.
- Channel 3 monitors voltage from the pressure transducer. This voltage varies as pressure increases and decreases, and it is converted into a pressure reading in either pounds per square inch (psi) or kilopascals (kPa). This voltage varies between approximately 1000 mV [0 psi. (0 kPa.)] and 4000 mV [200 psi. (1387 kPa.)].
- Channel 4 monitors machine voltage. This value varies as the voltage to the machine varies from the power source.
- Channel 5 displays one half of the voltage available to the pressure transducer. The voltage should always be around 2500 mV.
- Channel 6 displays resolver bias reference voltage. The voltage should be around 2500 mV.
- Channel 7 through 11 are not currently used, but may display random values which should be ignored.

Reviewing A/D

To review analog voltages, press **SYSTEM**, **2**, **1** to display the A/D screen. See Figure 55-2.

PULSES PER MINUTE							
0	3131	2	3064	4	2501	6	0
1	912	3	3621	5	0	7	0
PRESS ANY KEY > 0/1 = 219.8 -> 291.3							

Figure 55-2

System

Data

Pulse

Pulse is used to review pulse counts from external equipment. There are five pulse channels, numbered 0 through 4, to count electrical pulses from external equipment:

- Channel 0 is reserved for the Flowmeter option. The flowmeter propeller produces a certain number of electrical pulses per gallon, or liter. Example: 1.250 pulses per gallon.
 - » Counter Reading for channel 0 counts and totals the electrical pulses from the flowmeter. This value is converted to millions of gallons, or cubic meters, and is displayed as Total Flow on the Flow/Wind/Temp screen.
 - » Pulses Per Minute for channel 0 provides the rate of pulses from the flowmeter in pulses per minute. This value is converted to gallons per minute, or liters per second, and is displayed as Flowmeter on the Flow/Wind/Temp screen.
- Channel 1 is reserved for the Wind Speed Indicator option. The wind speed pulses are provided by an anemometer. Two pulses are recorded for each turn of the anemometer.
 - » Counter Reading for channel 1 counts and totals the electrical pulses from the anemometer. This value is NOT converted or displayed on the Flow/Wind/Temp screen.
 - » Pulses Per Minute for channel 1 provides the rate of pulses from the anemometer in pulses per minute. This value is converted to miles per hour, or meters per second, and is displayed as Wind on the Flow/Wind/Temp screen.
- Channels 2 through 4 are for expansion purposes.

NOTE

Refer to COUNT in the System/Data section to review or set counter values.

Reviewing Pulse

To review pulse count totals and rates, press **SYSTEM**, **2**, **2** to display the pulse screen. See Figure 56-1.

```
                PULSES PER MINUTE
0      0 2      0 4      0
1      0 3      0
PRESS ANY KEY >
```

Figure 56-1

Data

Modules

Module is used to review the condition of, and control all input and output relays used to monitor and control the machine. The following relay conditions are displayed on the Modules screen:

- **PRESSURE** - indicates if the water pressure is above or below the low pressure limit.
 - » ON indicates a pressure higher than the low pressure limit.
 - » OFF indicates a pressure lower than the low pressure limit.
- **AUXOUT1/AUXOUT2** - monitors the contacts of the relays that control voltage from the panel to auxiliary equipment.
 - » ON indicates the contacts are closed.
 - » OFF indicates the contacts are open.
- **AUXIN1/AUXIN2** - monitors/senses feedback to the panel from auxiliary equipment. These are 120-Volt relays, and can be wired to monitor AUXOUT1 and AUXOUT2 as shown on the wiring diagram on the control panel door.

Module is another name for a relay. The machine is controlled by a series of relays located in the control panel. Each relay is either closed (ON) or open (OFF) as the machine is operating. The user can enter a module number, and it is monitored in the upper right hand corner of the screen. A list of the module numbers and their corresponding relays is shown in Figure 57-1.

MODULE NUMBER	RELAY NUMBER	FUNCTION DESCRIPTION	RELAY BOARD TERMINAL
0	K1	Safety Out	J5-1
1	K2	Percent Timer	J5-2
2	K7	End Gun	J13-5
3	K8	Wide Boundary	J13-6
4	K6	Pump Safety	J13-1, 2, 3
5	K9	Alarm	J6-1, 2, 3
6	K12	Auxiliary 1 Output	J7-1, 2
7	K13	Auxiliary 2 Output	J7-3, 4
8	K4	Contactor Enable	J5-5, 6
9	K3	Direction (Forward=ON, Reverse=OFF)	J5-3, 4
10	D03	Control Panel Backlight	J15-5
11	D02	TTL Output 2	J15-4
12	D01	TTL Output 1	J15-3
13	R01	Low Side 1	J15-1
14	R02	Low Side 2	J15-2
15		Not Used	
16		Remote Start	J6-5
17		Pressure	J6-4
18	K5	3 Second timer	
19	K15	Auxiliary 2 Input	J7-7, 8
20	K14	Auxiliary 1 Input	J7-5, 6
21	K10	Reverse Sense	J5-4
22	K11	Forward Sense	J5-3
23	K5	Safety Sense	J5-7
24		PC4	J16-9
25		PC5	J16-10

Figure 57-1 Modules and Their Relays

Reviewing Modules

To review module relays, do the following:

1. Press **SYSTEM**, **2**, **3** to display the Module screen. See Figure 57-2.
2. To review a specific module/relay, press **1** to display the Module Request screen.
3. Enter the desired module number. See Figure 57-3.
4. Press **ENTER** to display the selected module. See Figure 57-4.

```

0 EXIT    PRESSURE...OFF  MODULE    0 OFF
1 MODULE  AUXOUT1....OFF  AUXIN1....OFF
          AUXOUT2....OFF  AUXIN2....OFF
PRESS NUMBER > 1
    
```

Figure 57-2

```

0 EXIT    PRESSURE...OFF  MODULE    0 OFF
1 MODULE  AUXOUT1....OFF  AUXIN1....OFF
          AUXOUT2....OFF  AUXIN2....OFF
ENTER MODULE NUMBER > 22
    
```

Figure 57-3

```

0 EXIT    PRESSURE...OFF  MODULE    22 ON
1 MODULE  AUXOUT1....OFF  AUXIN1....OFF
          AUXOUT2....OFF  AUXIN2....OFF
PRESS NUMBER >
    
```

Figure 57-4

System

Data

Flow/Wind/Temp

Flow/Wind/Temp provides flow meter, wind speed, and temperature information from the Flowmeter, Wind, and Temp options.

- Total flow is displayed in millions of gallons, or cubic meters.
- Flow rate is displayed in gallons per minute, or liters per second.
- Wind speed is displayed in miles per hour, or meters per second.
- Temperature is displayed in degrees (°F or °C).

Reviewing Flow/Wind/Temp

To review Flow/Wind/Temp information, press **SYSTEM**, **2**, **4** to display the Flow/Wind/Temp screen. See Figure 58-1.

```
TOTAL FLOW.....(MIL. GAL.)      0.000
FLOWMETER.....(GAL./MIN.)       0
TEMP..(DEG F)  0  WIND..(MPH)    1
PRESS ANY KEY >
```

Figure 58-1

End Water Pressure

The End Water Pressure Data screen is only available when the End Pres protocol is enabled. To review water pressure information for the pivot point and end pressure, do the following.

1. Press **SYSTEM**, **2**, **5** for the End Water Pressure Data screen. See Figure 58-2.
2. Verify water pressure readings at the pivot point and the end of the machine. End Of Machine water pressure is shown only when a valid sensor ID is configured to a valid TPMS tower box ID.
 - OLD - sensor or TPMS tower box has not responded for two or more hours.
 - Water Pressure - shown as PSI (Standard Units) or KPA (Metric Units).
 - "- "- there is no data to show.

```
WATER PRESSURE          PRESS ESC TO EXIT
PIVOT POINT..... 28 PSI  LAST UPDATE
END OF MACHINE.... 14 PSI   15 MIN
```

Figure 58-2

Count

Count provides counter readings from counters 0 through 4. Counters are set to zero when System Reset is executed.

Review / Set Count

To review or set counter readings, do the following.

1. Press **SYSTEM**, **2**, **6** to display the Count screen. See Figure 58-3.
2. Review the counter readings, or press a counter number to set the count.

```
                COUNTER READING
0                0 2                0 4                0
1                0 3                0
PRESS #..SET COUNTER OR ESC..EXIT >
```

Figure 58-3

Data

Tire Pressure

The Tire Pressure Data screen is only available when the TIRE PRES protocol is enabled. To review tire pressure information do the following:

1. Press **SYSTEM**, **2**, **7** for the Tire Pressure Data screen. See Figure 59-1.
2. Use the **↑**, **↓** buttons to select tower the number (TOWER #-).
3. Verify the tire pressure readings at each tire position shown (R, MR, M, MF, F). Only tires with a valid sensor ID configured on the tower are shown.
 - OLD - sensor or TPMS has not responded for two or more hours.
 - LOW - tire pressure is at or below pressure drop warning value.
 - OK - pressure is above pressure drop warning value.
 - "- "- there is no data to show.

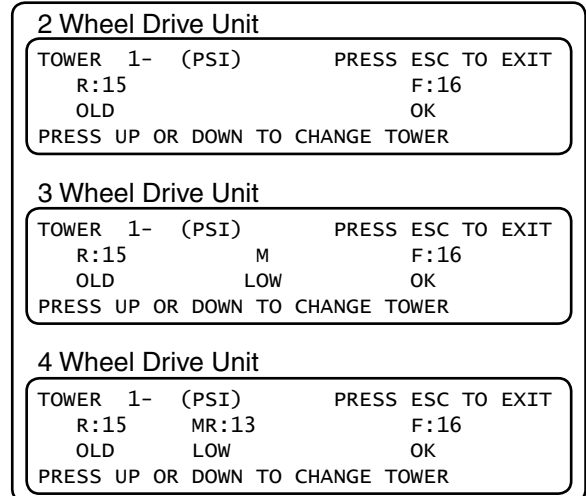

Figure 59-1 Tire Pressure Data Screen

Reset

Reset is used to clear the battery-backed memory. If Reset is executed, it sets the following machine operating conditions back to their default values:

Default Operating Values:

- DIRECTION = FORWARD
- WATER = WATER OFF
- SIS = SIS OFF
- All counter readings are reset to zero.
- Flow/Wind/Temp screen values are reset to zero.
- AUX 1 and 2 are reset to OFF.

CAUTION

If Reset is executed while the machine is running, the machine continues to run, Direction is set to FORWARD, Water is set to OFF, Stop-In-Slot is set to OFF, and AUX1 and AUX2 are set to OFF.

Using Reset

To reset battery-backed memory, follow these steps:

1. Press **SYSTEM**, **3** to display the reset screen. See Figure 59-2.
2. Press **1** to RESET.
or
Press **0** to EXIT without resetting.

```
*****WARNING*****
THIS WILL RESET SYSTEM TO DEFAULTS!
0..EXIT 1..RESET
PRESS NUMBER >
```

Figure 59-2

System

Review

REVIEW provides a record of the 99 most recent machine operation status changes via the History Review screen. The History Review screen number is in the lower left hand corner. REVIEW 01 is the newest status change and REVIEW 99 is the oldest status change. See Figure 60-1.

Following are the machine operation status changes (triggered events) that create review records.

- Changes to Percent Timer or application depth
- Program loaded or a program finishes executing
- Auto-Restart feature becomes active or inactive
- System starts or stops
- System direction changes
- Stop-In-Slot is turned on or off
- Stop-In-Slot position is crossed
- Stop-In-Slot position changed
- Water is turned on or off
- Auxiliary 1 and 2 are turned on or off
- Program command to trigger an event log
- Date changed or a midnight event log occurred
- VRI-Speed or VRI-Zone is turned on or off
- Cruise Control is turned on or off
- AD10 converter voltage is high or low
- End Gun (EG), Wide Boundary (WB), WB #2, or WB #3 is turned on or off

06:59:52		0.0 DEG STOPPED
08/11/14	*CRUISE*	123. .PSI FORWARD
480 VOLTS	E12	100.0 % WATER. ON
REVIEW.01	*AUX1 ON*	0.25 IN SIS= OFF

Figure 60-1

Review (continued)

The following information is logged for each History Review screen, and is accessed by pressing the OPTIONS button while viewing a review screen.

History Review Screen Event Codes

Pos.	Code	Event
01	00	Date Change/Midnight event log
02	01	Percent Timer or Water Depth change
03	02	One or more step programs are running or no programs are running
04	03	Program command triggers an event log
05	04	Auto restart feature active/inactive change
06	05	System direction change
07	06	Water on/off change
08	07	SIS on/off change
09	08	SIS position change
10	09	Cruise on/off change
11	0A	VRI-Z on/off change
12	0B	VRI-S on/off change
13	0C	Auxiliary In 1 change
14	0D	Auxiliary In 2 change
15	0E	Auxiliary Out 1 change
16	0F	Auxiliary Out 2 change
17	10	End Gun on/off change
18	11	Wide Boundary on/off change
19	12	PLC Wide Boundary 2 on/off change
20	13	PLC Wide Boundary 3 on/off change
21	14	AD10 high/low change
22	15	System crossed SIS position (Doesn't have to be on)
	16-7F	
23	80	Running
24	81	Waiting

Pos.	Code	Event
25	82	Paused (Reserved use)
26	83	Stopped - Power Fault
27	84	Stopped - Safety Fault
28	85	Stopped - Low Pressure Fault
29	86	Stopped - High Pressure Fault
30	87	Stopped - Water Timer Fault
31	88	Stopped - Command Fault
32	89	Stopped - SIS Fault
33	8A	Stopped - Program Fault
34	8B	Stopped - AutoStop Fault
35	8C	Stopped - BBRAM Fault
36	8D	Stopped - Flow Fault
37	8E	Stopped - For/Rev Fault
38	8F	Stopped - Tire Pressure Fault
39	90	Stopped - Wind Fault
40	91	Stopped - Temperature Fault
41	92	Stopped - Daily Ops Fault
42	93	Stopped - No Acknowledge Fault
43	94	Stopped - GPS Com Fault
44	95	Stopped - GPS Lock Fault
45	96	Stopped - Transition Fault (Reserved use)
46	97	Stopped - Rain Fault
47	98	Stopped - Relay Com Fault
48	99	Stopped - Boundary Fault
	9A-FF	

System

Using Review

The Auxiliary/Error Review screen displays a record of all auxiliary relay conditions and all error codes related to the status review screen being displayed. Reading from right to left, each error code is represented by a 0 placeholder. If an error occurred, the placeholder representing the error code is changed from 0 to 1. See Figure 62-1.

To review status changes, follow these steps:

1. Press **SYSTEM**, **4** to display the REVIEW screen. See Figure 62-2.
2. To view a status review screen do the following.
 - Press **1** to SEARCH BACKWARD toward status review screen 99.
 - Press **2** to SEARCH FORWARD toward status review screen 01.
3. While on the desired status review screen, the user can do the following.
 - Press **OPTIONS** to display the Auxiliary/Error Review screen. See Figure 62-3.
 - Press **OPTIONS** again to return to the status review screen.

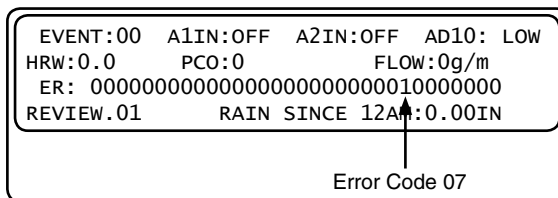

Figure 62-1

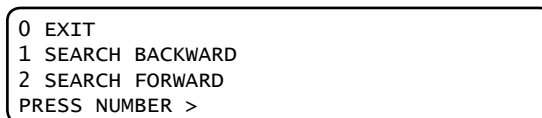

Figure 62-2

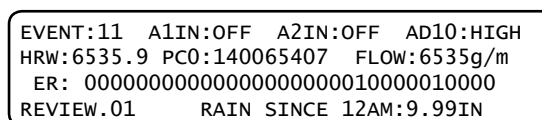

Figure 62-3

Cycle

Cycle provides the following information about the Daily OPS cycle.

- Cycle Repeat ON or OFF
- LAST Cycle date
- NEXT Cycle date (only displayed when Daily OPS cycle is ON)

Reviewing Cycle

To review cycle information, press **SYSTEM**, **5** to display the Cycle Information screen. See Figure 63-1.

```
CYCLE REPEAT: ON
LAST CYCLE:   03/21/14
NEXT CYCLE:   03/21/14
PRESS ANY KEY >
```

Figure 63-1

Transmit

TRANSMIT sends current status information through an optional communication device such, as a radio or telephone, to another control panel or base station equipped with a similar communication device. There is a random 0 to 10 second delay prior to the transmission of data.

Using Transmit

To transmit current status information, press **SYSTEM**, **6** to transmit information. See Figure 63-2.

```
0 EXIT          3 RESET      6 TRANSMIT
1 CONSTANTS    4 REVIEW     7 LANGUAGE
2 DATA        5 CYCLE     8 HOURS
PRESS NUMBER >
```

Figure 63-2

Language

Language is used to set the language and units of measure to be displayed on the screen and used in operating the machine.

Standard Inch measurement:

- Application rate in inches (in)
- Linear distance in feet (ft)
- Water pressure in pounds per square inch (psi)
- Date by month/day/year
- Flow in gallons per minute (GPM) and millions of gallons

International Metric measurement:

- Application rate in millimeters (mm)
- Linear distance in meters (m)
- Water pressure in kilopascal (kPa)
- Date by day/month/year
- Flow in liters per second (LPS) and cubic meters

System

Setting Language And Units Of Measure

To select or change the language or unit of measure, follow the steps below.

1. Press **SYSTEM**, **7** for the Language screen. See Figure 64-1.

2. Press the number associated with the desired language.

1 = English

2 = Spanish

3 = French

4 = Italian

5 = Portuguese

6 = Romanian

7 = Hungarian

3. Press the number associated with the desired unit of measure. See Figure 64-2.

0 = Standard inch measurement.

1 = International metric measurement.

NOTE: The value shown in parenthesis indicates the current value.

```
0 EXIT      3 FRANCAIS  6 ROMANA
1 ENGLISH   4 ITALIANO  7 MAGYAR
2 ESPANOL  5 PORTUGUES
PRESS NUMBER >
```

Figure 64-1

```
0 EXIT      3 FRANCAIS  6 ROMANA
1 ENGLISH   4 ITALIANO  7 MAGYAR
2 ESPANOL  5 PORTUGUES
0..IN  1..MM (0) >
```

Figure 64-2

Hours

Hours displays the cumulative hours of machine operation.

Total Hours displays the cumulative hours of both wet and dry operation. Total Hours can be changed by the operator, but only an increase in total hours is accepted.

Hours Wet displays only the hours that the machine was operated with water, or wet. Hours Wet can be changed by the operator. An increase or decrease is accepted.

Using Hours

To view or set total hours or hours wet, follow these steps.

1. Press **SYSTEM**, **8** to view TOTAL HOURS and HOURS WET. See Figure 65-1.
2. At the hours screen, do one of the following:
 - Press **0** to EXIT.
 - Press **1** to increase total hours.
 - » Enter the desired total number of hours. The total number of hours can only be increased. Decimal values are not allowed.
 - » Press **ENTER** to retain the value. See Figure 65-2.
 - Press **2** to adjust HOURS WET.
 - » Enter the number of hours wet. The number of hours wet can be increased or decreased. Decimal values are not allowed.
 - » Press **ENTER** to retain the value. See Figure 65-3.

NOTE: The value shown in parenthesis indicates the current value.

```

0 EXIT
1 TOTAL HOURS.. 567.3
2 HOURS WET.... 74.2
PRESS NUMBER >
  
```

Figure 65-1

```

0 EXIT
1 TOTAL HOURS.. 567.3
2 HOURS WET.... 74.2
HOUR METER ( 625) >
  
```

Figure 65-2

```



0 EXIT
1 TOTAL HOURS.. 567.3
2 HOURS WET.... 74.2
HOURS WET ( 95) >
  
```

Figure 65-3

Options Screen

The user can change settings or view information at anytime from the Options screen. The following functions are accessed from the Options screen.

- AUX1
- AUX2
- Remote Lockout
- Notice Callout
- Cruise Control
- AR/AS (Auto Reverse/Auto Stop)
- Autorestart
- End guns
- Forward/Reverse Position
- START\$
- STOP\$
- CYCLE\$
- Module
- VRI

1. Press  for the first Options screen. See Figure 67-1.
2. Press  for the second Options screen. See Figure 67-2.

```
0 EXIT  3 REMOTE LOCKOUT  6 AR/AS
1 AUX1  4 NOTICE CALLOUT 7 AUTORESTART
2 AUX2  5 CRUISE CONTROL  8 OTHER
PRESS NUMBER >
```

Figure 67-1 Options Screen 1

```
0 EXIT          3 START$      6 MODULE
1 END-GUNS     4 STOP$       7 VRI
2 FOR/REV-POS  5 CYCLE$
PRESS NUMBER >
```

Figure 67-2 Options Screen 2

Auxiliary Relays

Use AUX1 to turn the Auxiliary 1 relay ON (closed) or OFF (open). Use AUX2 to turn the Auxiliary 2 relay ON (closed) or OFF (open). When a relay is ON, it can control a contactor, solenoid, or other device.

If Auxiliary 1 relay is ON, it is displayed on the main status screen. However, if Auxiliary 2 relay is ON, it is not displayed on the status screen. See Figure 67-3.

```
10:47:55                285.0 DEG STOPPED
08/08/07                0..PSI FORWARD
484 VOLTS      E11      25.0 % WATER OFF
REVIEW.01 *AUX1 ON*    0.60 IN SIS= OFF
```







Figure 67-3

⚠ CAUTION

- **AUXILIARY RELAYS ARE INTENDED FOR IRRIGATION EQUIPMENT ONLY. OTHER EXTERNAL USES MAY CAUSE INTERFERENCE WITH, OR EXCESSIVE LOAD ON THE TRANSFORMER. CONSULT WITH YOUR VALLEY DEALER BEFORE USING AUXILIARY RELAYS.**
- **IF AUXILIARY RELAYS #1 OR #2 ARE USED TO CONTROL AN INJECTOR PUMP, THE SCHEMATIC FOR THE CONTROL PANEL MUST BE FOLLOWED WHEN WIRING. THIS ENSURES OPERATION OF THE INJECTOR PUMP ONLY WITH SUFFICIENT WATER PRESSURE.**

Using AUX1 or AUX2

To turn the AUX1 option or AUX2 option ON or OFF, do the following.

1. See Figure 67-4 and select one of the following.
 - For AUX1, press ,  to display the AUX1 screen.
 - For AUX2, press ,  to display the AUX2 screen.
2. Press  for ON or  for OFF.

```
0 EXIT  3 REMOTE LOCKOUT  6 AR/AS
1 AUX1  4 NOTICE CALLOUT 7 AUTORESTART
2 AUX2  5 CRUISE CONTROL  8 OTHER
AUX1 1..ON 0..OFF (OFF) >
```

Figure 67-4

Options

Remote Lockout

Remote Lockout is used to block communications between a BaseStation, or another remote control device, and the Pro2 control panel. When remote lockout is ON, the Pro2 control panel cannot be controlled remotely.

To turn the remote lockout ON or OFF:

1. Press **OPTIONS**, **3** to display the Remote Lockout screen.
See Figure 68-1.
2. Press **1** for LOCK or press **0** for UNLOCK.

NOTE: The value shown in parenthesis indicates the current value.

```
0 EXIT  3 REMOTE LOCKOUT  6 AR/AS
1 AUX1  4 NOTICE CALLOUT 7 AUTORESTART
2 AUX2  5 CRUISE CONTROL  8 OTHER
REMOTE LOCKOUT 1..LOCK 0..UNLOCK (0) >
```

Figure 68-1

Notice Callout

Use Notice Callout to configure communications and enable event notification for the real-time update feature, where the control panel is able to transmit a notice that its status has changed. This provides the BaseStation2 with status information at the time that the change occurs, rather than requiring the BaseStation2 to request it at a later time.

Notice Callout is grouped according to event types, which are shutdown, warning, and operational status changes.

Pro2 System Constants and Com Port communications must be configured, and Options Notice Events must be enabled before real-time updates notify the BaseStation2 that the status has changed.

To use real-time updates:

1. The Pro2 module software must be version 8.03 or later.
2. The following Pro2 System Constants for Com Port must be configured, based on the method of communication with the BaseStation2.
 - Protocol for the selected Com Port must be set to Remote Control.
 - Baud Rate
 - Hardware Flow Control
 - Key Wait
 - Configuration Notice:
 - » Base ID
 - » Modem Type
 - » Callout Tries
 - » Radio Hop
 - » Phone Number
 - » Notice ON/OFF must be ON.
3. Selected Pro2 Options Notice Events must be enabled.
4. The BaseStation software must be BaseStation2, version 6.0 or later.
5. If a radio is used, it must be set to monitor channel busy information.
6. The radio and modem hardware must support the flow control signals in order to use the Clear To Send (CTS) or Data Carrier Detect (DCD) settings.
7. Reprogramming the radio with modifications, or replacing the modem and harness may be necessary. Contact your Valley dealer for more information.

Options

Notice Callout

Event Notification

There are three Event Notification groups:

- Shutdown - defined as unplanned shutdowns.
- Warning - defined as unstable operating conditions.
- Status Change - defined as locally controlled events that the Base Station needs to be aware of.

The default state for all event notifications is DISABLED. When an event is enabled and the event occurs, a real-time update is sent from the control module to the BaseStation2 when the radio channel is clear. On the BaseStation2 main window, the user is notified that there has been a real-time update when the name of a machine turns to WHITE on a BLACK background. Alarms may be triggered, depending on the configuration of the alarms for the machine.

Shutdown Events

- The safety circuit opens for longer than three seconds.
- The system pressure drops below the low-pressure limit for longer than 30 seconds.
- Voltage drops below the low-voltage limit for longer than 15 seconds.
- Wind speed increases above the high wind speed limit for longer than one minute.
- Relay communications drop out, causing the machine to shut down.
- Machine stops due to power outage. A real-time update is sent when power is restored.

Warning Events

- Safety is interrupted more than 2 times in a 30 second period. (The system does not lose safety long enough to trigger a fault).
- Pressure drops below the low-pressure limit more than 2 times in a 30 second period. This feature is not active until after the low pressure delay timer has expired. (The pressure is not below the low-pressure limit long enough to trigger a fault).
- Voltage drops below the low voltage limit more than 2 times in a 30 second period. (The voltage is not below the low voltage limit long enough to trigger a fault).
- When the Pro2 module's computer is reset, and it's operating system restarts.
- Certain system constants were modified. These constants are SIS, END-GUN, PRES DLY, LOW PRES, MIN APP, HRS/REV, WIDE BND, and AR/AS.
- Auxiliary input #1 changes state.
- Auxiliary input #2 changes state.

Status Change Events

- Running/Stopped status change.
- Depth/Percent change.
- Direction changes (forward/reverse).
- Daily OPS Enable is turned on/off.
- A step in a user program finishes executing.
- When the end gun is enabled, and on/off status changes (does not include wide boundary).
- Stop-In-Slot Enable is turned on/off.
- Position changes by more than a user-defined degree interval from 1° - 359°. The default value is 10°. (The user is prompted to enter the number of degrees when the option is toggled to the enabled state).
- Absolute position that is a user-defined degree from 0.0° - 359.9°. The default value is 180.0°. (The user is prompted to enter the position, in degrees, when the option is toggled to the enabled state).

Notice Callout

Events

Use Events to display the Shutdown, Warning, and Status Change Events notification menus. Then, enable or disable notification to the BaseStation2 for only selected events, if the event should occur.

Shutdown Events

To enable or disable notification to the BaseStation2 for the listed system fault events, do the following.

1. Press **OPTIONS**, **4**, **1** to display the Shutdown screen.
See Figure 71-1.

2. Enable or disable the following events as desired:

- Press **1** for SAFETY fault.
- Press **2** for PRESSURE fault.
- Press **3** for VOLTAGE fault.
- Press **4** for WIND fault.
- Press **5** for RELAY COM fault.
- Press **6** for TIRE PRESSURE fault.

```
0 EXIT          3 VOLTAGE      6 TIRE PRESSURE
1 SAFETY       4 WIND
2*PRESSURE    5 RELAY COM
PRESS NUMBER TO TOGGLE >      *= ENABLED
```

Figure 71-1

Warning 1 Events

To enable or disable notification to the BaseStation2 for the listed events, do the following.

1. Press **OPTIONS**, **4**, **2** to display the Warning 1 screen.
See Figure 71-2.

2. Enable or disable the following events as desired:

- Press **1** for SAFETY.
- Press **2** for PRESSURE.
- Press **3** for VOLTAGE.
- Press **4** for CPU RESET.
- Press **5** for NEW CONSTANT.

```
0 EXIT          3 VOLTAGE
1 SAFETY       4 CPU RESET
2*PRESSURE    5 NEW CONSTANT
PRESS NUMBER TO TOGGLE >      *= ENABLED
```

Figure 71-2

Warning 2 Events

To enable or disable notification to the BaseStation2 for the listed events, do the following.

1. Press **OPTIONS**, **4**, **3** to display the Warning 2 screen.
See Figure 71-3.

2. Enable or disable the following events as desired:

- Press **1** for AUX1 IN STATUS.
- Press **2** for AUX2 IN STATUS.
- Press **3** for TIRE PRESSURE.

```
0 EXIT          3 TIRE PRESSURE
1*AUX1 IN STATUS
2 AUX2 IN STATUS
PRESS NUMBER TO TOGGLE >      *= ENABLED
```

Figure 71-3

Options

Notice Callout

Events (continued)

Status Change 1 Events

To enable or disable notification to the BaseStation2 for the listed events, do the following.

1. Press **OPTIONS**, **4**, **4** to display the Status Change 1 screen. See Figure 72-1.
2. Enable or disable the following events as desired.
 - Press **1** for RUN/STOP.
 - Press **2** for DEPTH/%.
 - Press **3** for FOR/REV.
 - Press **4** for DAILY ON/OFF.
 - Press **5** for PGM STEP.

0 EXIT	3 FOR/REV
1*RUN/STOP	4 DAILY ON/OFF
2 DEPTH/%	5 PGM STEP
PRESS NUMBER TO TOGGLE > *= ENABLED	

Figure 72-1

Status Change 2 Events

To enable or disable notification to the BaseStation2 for the listed events, do the following.

1. Press **OPTIONS**, **4**, **5** to display the Status Change 2 screen. See Figure 72-2.
2. Enable or disable the following events as desired.
 - Press **1** for END GUN.
 - Press **2** for SIS ON/OFF.
 - Press **3** for DEG CHANGE (10).
 - Press **4** for ABS DEGREE (0.0).

0 EXIT	3 DEG CHANGE (10)
1*END GUN	4 ABS DEGREE (0.0)
2 SIS ON/OFF	
PRESS NUMBER TO TOGGLE > *= ENABLED	

Figure 72-2

Cruise Control

CRUISE CONTROL allows the user to set a time period for the center pivot to travel a specified number of degrees. Cruise Control adjusts the machine speed so that the center pivot travels the specified number of degrees within the user set period of time. Center pivot speed cannot exceed 100%

Enable/Disable Cruise Control

Cruise Control can be enabled or disabled by doing the following.

1. Press **OPTIONS** and **5** for CRUISE CONTROL. See Figure 73-1.
2. Select one of the following options (system default is DISABLE):

```
0 EXIT  3 REMOTE LOCKOUT  6 AR/AS
1 AUX1  4 NOTICE CALLOUT 7 AUTORESTART
2 AUX2  5 CRUISE CONTROL  8 OTHER
PRESS NUMBER >
```

Figure 73-1

- Press **1** to ENABLE. See Figure 73-2.
 - » Enter the desired number of hours for the center pivot to complete the number of degrees that are set. The default is 24.0 hours. The range is 0.1 to 65535.9 hours. See Figure 73-3.
 - » Press **ENTER** to retain the value.

```
0 EXIT  3 REMOTE LOCKOUT  6 AR/AS
1 AUX1  4 NOTICE CALLOUT 7 AUTORESTART
2 AUX2  5 CRUISE CONTROL  8 OTHER
CRUISE 1..ENABLE  0..DISABLE (0) >
```

Figure 73-2

or

- » Press **0** to DISABLE.

```
0 EXIT  3 REMOTE LOCKOUT  6 AR/AS
1 AUX1  4 NOTICE CALLOUT 7 AUTORESTART
2 AUX2  5 CRUISE CONTROL  8 OTHER
ENTER HOURS (65535.9) >
```

Figure 73-3

NOTE: When Cruise Control is enabled, VRI Speed Control is automatically turned off.

Control Panel Display

Indication that Cruise Control (CRUISE) is enabled (ON), or running, is shown on the Control Panel Status screen.

- When Cruise Control is enabled and ON on the Control Panel Status screen:
 - » "CRUISE" is displayed on the status screen. See Figure 73-4.
 - » If Restart is also on, "CRUISE" cycles with *RESTART" on the status screen. See Figure 73-4.
 - » The "hours per rev" display on the status screen now displays "hours per pass". The range is 0 to 65535.9 hours. See Figure 73-4.
 - » The error code display on the status screen cycles with the adjusted percentage "ADJ. %" display. See Figure 73-4.
 - » Only error codes 1,2,5,7,8,12-14,17-19 and 21 are shown on the status screen.
- "CRUISE" is NOT displayed on the status screen when Cruise Control is disabled (OFF).

```
10:05:38 *PROGRAM* 90.7 DEG RUNNING
01/13/10 *CRUISE * 37..PSI FORWARD
477 VOLTS 96.5 % 95.0 % WATER. ON
25.4 HR*AUX1 ON* 0.26 IN SIS= 90.5
```



```
10:05:38 *PROGRAM* 90.7 DEG RUNNING
01/13/10 *RESTART * 37..PSI FORWARD
477 VOLTS E01 95.0 % WATER. ON
65535.9 HR*AUX1 ON* 0.26 IN SIS= 90.5
```

Figure 73-4

Position Values

Cruise Control works with Resolver, GPS, or Runtime Positioning.

- If GPS is not activated, position values are provided by the Resolver.
- If GPS is activated, position values are provided by the GPS receiver. But, when there is no GPS signal the position resorts to using backup, either Runtime or Resolver. An E18 error is recorded.

Options

AR/AS (Auto Reverse/Auto Stop)

Use the Auto Reverse option to select the desired function of the drive-unit-mounted end-of-field stop/auto-reverse when the actuator arm is tripped. Choose either auto reverse or auto stop.

To use this option, the machine must be equipped with a drive-unit-mounted end-of-field stop/auto-reverse, and Auto Reverse must be enabled by setting the AR/AS constant to ON.

- If the AR/AS constant is set to OFF, the message "AUTOREVERSE (DISABLED)" is displayed on the bottom line of the Auto Reverse screen. See Figure 74-1.

NOTE: Refer to the AR/AS information in the System section to enable or disable Auto Reverse.

```
0 EXIT 3 REMOTE LOCKOUT 6 AR/AS
1 AUX1 4 NOTICE CALLOUT 7 AUTORESTART
2 AUX2 5 CRUISE CONTROL 8 OTHER
AUTOREVERSE (DISABLED) >
```

Figure 74-1



- If the machine is not equipped with a drive-unit-mounted end-of-field stop/auto-reverse, the control panel should be programmed to change directions, and the Auto Reverse option should be ignored.

CAUTION

• IF THE MACHINE NEEDS TO REVERSE AROUND AN OBSTACLE SUCH AS A TREE LINE, BUILDING, OR FENCE, A DRIVE-UNIT-MOUNTED END-OF-FIELD STOP/AUTO-REVERSE MUST BE INSTALLED, WITH PHYSICAL BARRICADES AS A SAFETY BACK-UP.

Using Auto Reverse

To select the desired Auto Reverse function, follow these steps.

1. Press ,  to display the Auto Reverse screen. See Figure 74-2.
2. Press the number associated with the desired command:

 = AR (auto reverse).

 = AS (auto stop).

NOTE: The value shown in parenthesis indicates the current state.

```
0 EXIT 3 REMOTE LOCKOUT 6 AR/AS
1 AUX1 4 NOTICE CALLOUT 7 AUTORESTART
2 AUX2 5 CRUISE CONTROL 8 OTHER
AUTOREVERSE 1..AR 0..AS ( AS ) >
```

Figure 74-2

Auto Restart

Use the Auto Restart option to restart a machine automatically if it was last shut down because of a loss of power or pressure.

- When Auto Restart is ON, a *RESTART* message is displayed on the status screen to remind the user that the machine is programmed to restart automatically. See Figure 74-3.

NOTE: The *RESTART* message is also shown on the status screen when DAILY OPS is on and activated. The user must verify that AUTO RESTART is on if a restart due to the loss of power or pressure is desired.

```
13:58:30 180 DEG RUNNING
08/08/07 *RESTART* 33 PSI FORWARD
477 VOLTS 50 % WATER ON
48.0 HR 0.50 IN SIS...90
```

Figure 74-3

- If the machine is shut down by pressing the STOP key, by the stop-in-slot position, or by a programmed shut down, Auto Restart is temporarily disabled by the control panel, and the *RESTART* message disappears from the status screen.
- If the operator starts the machine again by pressing the START key, or by a programmed start, the *RESTART* message appears on the status screen and auto restart is active again.

Auto Restart (continued)

Pressure Restart

When Auto Restart is on and a shutdown occurs because of a loss of pressure, the machine restarts when pressure is regained and reaches the low pressure limit. Pressure restart does NOT use the START\$ program, unless the power is cycled. If a machine restarts due to a loss of pressure, it starts with the same running conditions as when it previously lost pressure, just as if START was pressed.

Power Restart

When Auto Restart is on and a shutdown occurs because of a loss of power, the control panel runs the START\$ program when power is restored.

The START\$ program must contain all commands required to restart the machine to the desired status, including an adequate delay and the Start command. This is important when a pump restart delay is required after a momentary loss of power resulting in a shutdown.

NOTE

- If START\$ is not programmed with a start-up procedure, power restart does not operate correctly, even though AUTORESTART is on.
- If a machine was shut down by pressing the STOP key, by the stop-in-slot position, or by a programmed shutdown, it does NOT power restart if the power disconnect was turned off and then on to simulate a loss of power, because the initial shutdown was not caused by loss of power or pressure.

Using Auto Restart

To command the auto restart option ON or OFF, follow these steps.

1. Press , to display the auto restart screen. See Figure 75-1.
2. Press for ON or for OFF.

NOTE: The value shown in parenthesis indicates the current state.

```
0 EXIT  3 REMOTE LOCKOUT  6 AR/AS
1 AUX1  4 NOTICE CALLOUT 7 AUTORESTART
2 AUX2  5 CRUISE CONTROL  8 OTHER
AUTORESTART 1..ON 0..OFF ( OFF ) >
```

Figure 75-1

Options

End Gun

Use the End Gun option to enable or disable the first End Gun, Wide Boundary, PLC Wide Boundary #2, and PLC Wide Boundary #3 options. Enabling or disabling any of these options does not affect the programmed Constants. See Figure 76-1.

Enable/Disable End Gun

To enable or disable an end gun, follow these steps.

1. Press **OPTIONS**, **8**, **1** to display the End Gun screen.
See Figure 76-1.
2. Press **1** to enable/disable the end gun.

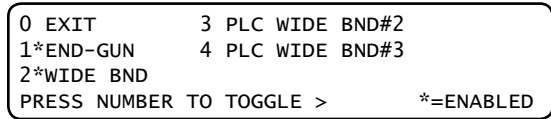

Figure 76-1

Enable/Disable Wide Bnd (Boundary)

To enable or disable wide boundary, follow these steps.

1. Press **OPTIONS**, **8**, **1** to display the End Gun screen.
2. Press **2** to enable/disable Wide Boundary.

NOTE

- PLC Wide Boundary #2 and #3 are only available when PLC WIDE BND is enabled on the System Constants Protocol PLC screen.

Enable/Disable PLC Wide Bnd #2

To enable or disable PLC Wide Boundary #2, follow these steps.

1. Press **OPTIONS**, **8**, **1** to display the End Guns screen.
2. Press **3** to enable/disable Wide Boundary #2.

Enable/Disable PLC Wide Bnd #3

To enable or disable PLC Wide Boundary #3, follow these steps.

1. Press **OPTIONS**, **8**, **1** to display the End Guns screen.
2. Press **4** to enable/disable Wide Boundary #3.

For/Rev Position

Use this option to change the machine's direction from forward to reverse, and from reverse to forward. Auto Reverse/Auto Stop (AR/AS) must be enabled for this option to work. If AR/AS is disabled, the Forward and Reverse Position settings do nothing.

Do the following to enable Forward/Reverse Position.

1. Press **OPTIONS**, **8**, **2** to display the Forward/Reverse Position screen. See Figure 77-1.

2. Press **1** to enable/disable the Forward/Reverse Position function.

If AR/AS has not been enabled, the display tells you. See Figure 77-2.

3. If AR/AS is not disabled, enter the left angle degree and press **Enter**. See Figure 77-3.
4. Enter the right angle degree and press **Enter**. See Figure 77-4.

```
0 EXIT          3 START$      6 MODULE
1 END-GUNS     4 STOP$       7 VRI
2 FOR/REV-POS  5 CYCLE$
FOR/REV POSITION 1..ON  0..OFF ( ON) >
```

Figure 77-1

```
0 EXIT          3 START$      6 MODULE
1 END-GUNS     4 STOP$       7 VRI
2 FOR/REV-POS  5 CYCLE$
FOR/REV POSITION (AR/AS DISABLED) >
```

Figure 77-2

```
0 EXIT          3 START$      6 MODULE
1 END-GUNS     4 STOP$       7 VRI
2 FOR/REV-POS  5 CYCLE$
FOR POS, LEFT ANGLE ( 0.0) >
```

Figure 77-3

```
0 EXIT          3 START$      6 MODULE
1 END-GUNS     4 STOP$       7 VRI
2 FOR/REV-POS  5 CYCLE$
REV POS, RIGHT ANGLE ( 0.0) >
```

Figure 77-4

Options

START\$ Program

The START\$ program is a special command string program that does not have a condition for the first step because it is executed immediately when commanded, either by another program or a machine function such as the CYCLE\$ EXECUTE command, the Power Restart option, or the Daily OPS function. Refer to START\$ program examples in the Step Program Example section.

The START\$ program is used to command how the machine should start, and is used by the Power Restart function, CYCLE\$, and Daily OPS. Listed below are two ways that the START\$ can be programmed.

1. Delayed START\$ program - a start up procedure that includes a delay before the WATER ON and START commands.
2. Immediate START\$ program - a start up procedure that only includes the START command.

Listed below are several important details about the START\$ program.

- The START\$ program can only be programmed for one situation at a time.
- The START\$ program does not automatically start the machine unless the START command is in the START\$ program.
- If Auto Restart is enabled, the Power Restart function executes the START\$ program. If running conditions are not specified in the START\$ program, the machine does not start for Power Restart or Pressure Restart after a pivot cycle.
- The START\$ program cannot be edited like a stored Step program. To change the START\$ program, the entire START\$ program must be rewritten.





CAUTION

- A DELAYED START IS RECOMMENDED TO REDUCE THE POSSIBILITY OF DAMAGE TO AN ELECTRIC PUMP IF POWER IS LOST AND REGAINED IN A SHORT PERIOD OF TIME.

START\$ Program

Using Review START\$

To review the START\$ program, follow these steps.

1. Press , , ,  to display the START\$ program review screen. See Figure 78-1.
The default program contains a 10 minute delay, followed by START.
2. Press any key to advance to the next step of the program, or to leave the screen.

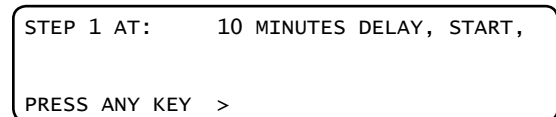

Figure 78-1

Using Write START\$

To write a delayed START\$ program, follow these steps (refer to the START\$ program examples in the Step Program Examples section).

1. Press **OPTIONS**, **8**, **3**, **2** to display the START\$ Program Write screen. See Figure 79-1.

When Write is selected, the program screen automatically starts with Program by Delay.

2. Select the type of delay, either seconds or minutes. This example uses minutes. See Figure 79-2.

- Press **0** for SECONDS.
- Press **1** for MINUTES.

3. Enter the appropriate length of delay for the application. This example uses 10 minutes. See Figure 79-3.

- Press **1**, **0** for 10 minutes.
- Press **ENTER** to retain 10 minutes.

4. Using the control panel program keys (Figure 79-4), enter the commands for STEP 1. The command appears on the screen when entered. See Figure 79-5.

5. Press **START**.

NOTE: The START\$ program MUST contain the START command.

6. When finished entering the command(s), press **ENTER**.
7. Finish the START\$ program. See Figure 79-6
8. Press **1** for PROGRAM FINISHED. The START\$ program is now saved.

Using Execute START\$

1. To immediately execute the START\$ program, press **OPTIONS**, **8**, **3**, **3**. See Figure 79-7.

```
STEP 1 PROGRAM BY: DELAY
DELAY 0..SECONDS 1..MINUTES >
```

Figure 79-1

```
STEP 1 PROGRAM BY: DELAY
DELAY 0..SECONDS 1..MINUTES > 1
```

Figure 79-2

```
STEP 1 PROGRAM BY: DELAY
ENTER DELAY IN MINUTES > 10
```

Figure 79-3

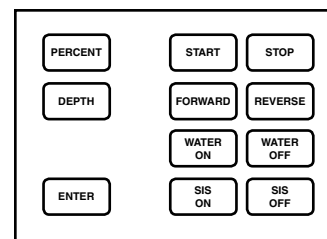

Figure 79-4

```
STEP 1 AT: 10 MINUTES DELAY, START,
WATER ON, FORWARD,
ENTER COMMANDS, FINISHED..PRESS ENTER
```

Figure 79-5

```
0 EXIT
1 PROGRAM FINISHED
2 NEXT STEP
PRESS NUMBER > 1
```

Figure 79-6

```
START$
0 EXIT 2 WRITE
1 REVIEW 3 EXECUTE
PRESS NUMBER > 3
```

Figure 79-7

Options

STOP\$ Program

The STOP\$ program is a special command string program that does not have a condition for the first step because it is executed immediately when commanded by the Daily OPS function. The STOP\$ program is used to command how the machine should stop after it completes its last cycle. Refer to the STOP\$ program example in the Step Program Examples section.

Listed below are some important details about the STOP\$ program:





- It is not necessary to write the STOP\$ program, unless the user wants the machine to do something in addition to the stop command.
- The STOP\$ program by default stops the machine, unless programmed to do otherwise.
- The STOP\$ command is NOT required to be in the STOP\$ program.
- The STOP\$ program can only be written for one situation at a time.

WARNING

• TO REDUCE THE POSSIBILITY OF SEVERE INJURY, DEATH, AND/OR MAJOR EQUIPMENT OR PROPERTY DAMAGE, NEVER USE THE START COMMAND IN THE STOP\$ PROGRAM.

Using Review STOP\$

To review the STOP\$ program, follow these steps.









1. Press , , ,  to display the STOP\$ program review screen. See Figure 80-1.
2. Press any key to advance to the next step of the program, or to leave the screen.

```
STOP,  
  
PRESS ANY KEY >
```

Figure 80-1

Using Write STOP\$

To write a simple STOP\$ program, follow these steps. Refer to the STOP\$ program example in the Program Examples section.

1. Press , , ,  to display the STOP\$ Write screen. See Figure 80-2.
2. Enter the desired commands to set the stopping conditions of the machine. When finished press . See Figure 80-3
3. Press  for the Next Step screen.
4. At the Next Step screen, do one of the following. See Figure 80-4.
 - Press  for EXIT (exits Write STOP\$ program).
 - Press  for PROGRAM FINISHED (saves program).
 - Press  for NEXT STEP (adds another step to the program).

```
WRITE STOP$,  
  
ENTER COMMANDS, FINISHED..PRESS ENTER
```

Figure 80-2





```
WRITE STOP$, STOP,  
  
ENTER COMMANDS, FINISHED..PRESS ENTER
```

Figure 80-3

```
0 EXIT  
1 PROGRAM FINISHED  
2 NEXT STEP  
PRESS NUMBER >
```

Figure 80-4

Using Execute STOP\$

1. To immediately execute the STOP\$ program, press , , , . See Figure 80-5.

```
STOP$  
0 EXIT      2 WRITE  
1 REVIEW   3 EXECUTE  
PRESS NUMBER >
```

Figure 80-5

CYCLE\$ Program

The CYCLE\$ program is a special command string program that does not have a condition for the first step because it is executed immediately when commanded by the CYCLE\$ EXECUTE command, or the Daily OPS cycle function. Refer to the CYCLE\$ program examples in the Step Program Examples section.

The CYCLE\$ program allows the operator to repeat a sequence of events for an irrigation cycle. A cycle may consist of one full pass, a full circle, or part circle. The operator commands the equipment to execute a number of cycles. The machine immediately starts, completes the desired number of cycles, and stops after the last cycle is completed.

When using the CYCLE\$ program, Stop-In-Slot must be off. If it is on, the machine stops at the stop-in-slot location after the first cycle.

An internal counter uses the stop-in-slot position as a reference point for counting the number of cycles that have executed. Each time the machine advances to the stop-in-slot position, the CYCLE\$ program is executed, and the number of times remaining to execute the CYCLE\$ program is reduced by one.

When the machine has advanced to the stop-in-slot position, and the number of times to execute the CYCLE\$ program has counted down to zero, the STOP\$ program is executed and the machine stops at the stop-in-slot position, even though Stop-In-Slot is off.

Using Review CYCLE\$

To review the CYCLE\$ program, follow these steps.

1. Press **OPTIONS**, **8**, **5**, **1** to display the CYCLE\$ Review screen. See Figure 81-1.
2. Press any key to advance to the next step of the program, or to leave the screen. See Figure 81-2.

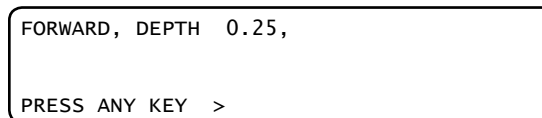

Figure 81-1

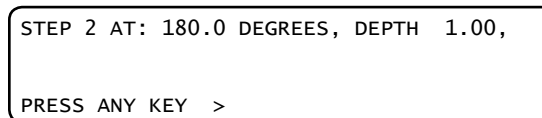

Figure 81-2

Options

CYCLE\$ Program (continued)

Write CYCLE\$

Use Write CYCLE\$ to create the CYCLE\$ program. The CYCLE\$ program's first step can immediately execute a command, or additional steps can be programmed by condition to execute commands, options, or stored programs. Refer to the CYCLE\$ program examples in the Step Program Examples section.

Listed below are several important details about writing a CYCLE\$ program.

- The CYCLE\$ program cannot be edited like a stored program. To change the CYCLE\$ program, the entire program must be rewritten.
- Do not change the machine direction either manually or within a stored program as this could cause the CYCLE\$ program to work incorrectly.
- If the machine is irrigating a partial circle, or is equipped with end-of-field stop/auto-reverse hardware, special consideration is required for writing and executing the CYCLE\$ program since the machine passes the stop-in-slot position while traveling in both directions.
- The CYCLE\$ program requires that the stop-in-slot position be within the boundaries of the partial circle.
- DO NOT use the stop-in-slot position as a condition in a CYCLE\$ program step, or a stored program step that is used by the CYCLE\$ program.
- A CYCLE\$ program step, or a stored program step that uses a position that is the same as the stop-in-slot position is not executed because the CYCLE\$ program restarts at its first step.

Available Commands

- Percent
- Depth
- Start
- Stop
- Forward
- Reverse
- Water ON
- Water OFF
- SIS ON
- SIS OFF

Available Options

- Auxiliary 1 ON/OFF
- Auxiliary 2 ON/OFF
- Module
- Auto Reverse (when enabled)
- Auto Restart

Stored Program

- Any stored Step program can be run from the last step of the CYCLE\$ program. Refer to Run a Stored Program From a Program in the Step Program section.

Programming Conditions Available

- Time - execute commands based on the date and time of day.
- Position - execute commands based on the position of the machine.
- Pressure - execute commands based on water pressure.
- Delay - execute commands based on a time delay in seconds or minutes.
- For/Rev - execute commands based on direction of machine movement.
- Other conditions - refer to Other Programming Conditions in the Step Program section.
 - » Analog - execute commands based on an analog channel and its value.
 - » Module - execute commands based on a module's status.
 - » Pulse - execute commands based on counter number and pulse rate.
 - » Count - execute commands based on counter number and count.

CYCLE\$ Program (continued)

Using Write CYCLE\$

To write the CYCLE\$ program, follow these steps. Refer to the CYCLE\$ program examples in the Program Examples section:

1. Press , , , to display the Write CYCLE\$ write screen. See Figure 83-1.

```
WRITE CYCLE$
ENTER COMMANDS, FINISHED..PRESS ENTER
```

Figure 83-1

2. Enter the desired commands to run the machine.

NOTE: During each cycle, the machine MUST pass the stop-in-slot position in order to execute the CYCLE\$ program again.

3. Press when finished.
4. At the next step screen, do one of the following. See Figure 83-2.

```
0 EXIT
1 PROGRAM FINISHED
2 NEXT STEP
PRESS NUMBER > X
```

Figure 83-2

- Press to EXIT (exits Write CYCLE\$ program).
- Press for PROGRAM FINISHED (to begin to save the program).
- Press for NEXT STEP (adds another step to the program).

Execute CYCLE\$

Use Execute CYCLE\$ to review, edit, or set the number of irrigation cycles, and then execute the CYCLE\$ program. The first execution of the CYCLE\$ program starts after the operator enters the number of cycles to execute, or a stored program step with the SET CYCLE% command is executed.

When a cycle is executed, the machine starts according to the start-up procedure in the START\$ program. The machine completes the desired number of cycles past the stop-in-slot position. Each cycle executes commands according to the steps in the CYCLE\$ program. After the machine completes the desired number of cycles, it stops according to the stop procedure in the STOP\$ program.

Listed below are some important details about executing the CYCLE\$ program:

- The number of cycles remaining to be executed can be reviewed and/or edited at any time to add additional cycles, or to reduce the number of cycles remaining.
- When the CYCLE\$ program is executed, the machine starts immediately and *PROGRAM* is displayed on the status screen until all commands for that cycle have been executed.
- If the operator stops the machine during a cycle, it can be restarted. The program resumes and complete the cycle(s) as programmed.
- Stop-In-Slot must be off when using the CYCLE\$ program, or the stop-in-slot function stops the machine after the first cycle.
- During each cycle, the machine MUST pass the stop-in-slot position in order to execute the CYCLE\$ program again.

Using Execute CYCLE\$

To execute the CYCLE\$ program, do the following:

1. Press , , , to display the execute CYCLE\$ screen. See Figure 83-3.

```
CYCLE$
0 EXIT    2 WRITE
1 REVIEW  3 EXECUTE
ENTER NUMBER OF CYCLES (0) >
```

Figure 83-3

2. Select the number of cycles to run, then press to immediately execute the CYCLE\$ program.

Options

CYCLE\$ Program (continued)

Using SET CYCLE\$ to Execute CYCLE\$

To execute the CYCLE\$ program at a specific time and date for a set number of cycles, program a Step program using the TIME condition, and use the Set Cycle command. Follow the steps below.

1. Press **PROGRAM**, **1**, **2**, **1** to display the Time screen. See Figure 84-1.
2. Press **0** for DATE/TIME.
3. Enter the desired date for cycle to begin, and press **ENTER**. See Figure 84-2.
4. Enter the desired time for cycle to begin, and press **ENTER**. See Figure 84-3.
5. The enter command screen is displayed. See Figure 84-4.
6. Press **OPTIONS**, **8**, **5** to display the CYCLE\$ screen. See Figure 84-5.
7. Enter the desired number of cycles to run, and press **ENTER**.
8. Press **ENTER** to finish the step. See Figure 84-6.
9. Press **1** for PROGRAM FINISHED. See Figure 84-7.
10. Select one of the following. See Figures 84-8 and 84-9.
 - Press **1** for SAVE PROGRAM.
 - (a) Select program number 1-17.
 - (b) Press **ENTER** to save the program.
 - Press **2** for SAVE PROGRAM AND RUN.
 - (a) Select program number 1-17.
 - (b) Press **ENTER** to save and run the program.
 - Press **3** for CANCEL PROGRAM to cancel the program.
 - Press **4** for RUN THEN DELETE to run the program once and then delete it.

```
STEP 1 PROGRAM BY: TIME  
  
PRESS 0..DATE/TIME 1..DAY/TIME (0) >
```

Figure 84-1

```
STEP 1 PROGRAM BY: TIME  
  
ENTER DATE (XX/XX/XX) >
```

Figure 84-2

```
STEP 1 PROGRAM BY: TIME  
  
ENTER TIME (XX:XX) >
```

Figure 84-3

```
STEP 1 AT: 08/08/07 06:30:00,  
  
ENTER COMMANDS, FINISHED..PRESS ENTER
```

Figure 84-4

```
0 EXIT          3 START$      6 MODULE  
1 END-GUNS     4 STOP$      7 VRI  
2 PERCENT      5 CYCLE$  
ENTER NUMBER OF CYCLES (X) >
```

Figure 84-5

```
STEP 1 AT: 08/08/07 06:30:00,  
SET CYCLE 4,  
  
ENTER COMMANDS, FINISHED..PRESS ENTER
```

Figure 84-6

```
0 EXIT  
1 PROGRAM FINISHED  
2 NEXT STEP  
PRESS NUMBER >
```

Figure 84-7

```
0 EXIT          3 CANCEL PROGRAM  
1 SAVE PROGRAM  4 RUN THEN DELETE  
2 SAVE PROGRAM AND RUN  
PRESS NUMBER >
```

Figure 84-8

```
STORED PROGRAMS  
  
PRESS NUMBER FROM 1 TO 17 TO SAVE.  
ENTER PROGRAM NUMBER >
```

Figure 84-9

Cycle\$ Program

Review or Edit Remaining Cycles

The number of cycles remaining to be executed can be reviewed at any time. The number can also be edited to add additional cycles, or to reduce the number of cycles remaining. To review or edit the current number of cycles remaining on the CYCLE\$ Execute screen, do the following.

1. Press **OPTIONS**, **8**, **5**, **3** to display the CYCLE\$ Execute screen. See Figure 85-1.
2. On the CYCLE\$ Execute screen, do one of the following:
 - Review the current number of cycles remaining (number in parenthesis), then press **ESC** to leave the screen without making changes.
 - Enter the desired number of cycles to run, then press **ENTER**.

```
STOP$
0 EXIT      2 WRITE
1 REVIEW    3 EXECUTE
ENTER NUMBER OF CYCLES (4) >
```

Figure 85-1

Module

Use the Module option to turn individual relays on the relay board on or off. The Module option should only be used by factory-trained Valley technicians.

Using Module

To command a module/relay on or off, follow these steps:

1. Press **OPTIONS**, **8**, **6** to display the module screen. See Figure 85-2.
2. Enter the number associated with the desired module/relay, and press **ENTER**.
3. Press **1** for ON or **0** for OFF. See Figure 85-3.

```
0 EXIT          3 START$    6 MODULE
1 END-GUNS     4 STOP$      7 VRI
2 FOR/REV-POS 5 CYCLE$
ENTER MODULE NUMBER >
```

Figure 85-2

```
0 EXIT          3 START$    6 MODULE
1 END-GUNS     4 STOP$      7 VRI
2 FOR/REV-POS 5 CYCLE$
MODULE X 1..ON 0..OFF (OFF) >
```

Figure 85-3

Options

VRI

VRI Speed Control

The VRI Speed (VRI-S) Control uses mapping software to divide the field into 180 sectors that relate to the sectors on a prescription map. Each sector has a resolution of two degrees.

At periodic intervals, the Pro2 control panel uses the VRI-S prescription along with the current resolver angle, GPS coordinates, or run time to determine and adjust the center pivot speed for each sector.

Example: If the set application of the Pro2 module is 1.00 in (25.4 mm), and the prescription has a value of 70% in the sector where the center pivot is currently running, the Pro2 module adjusts the speed of the center pivot to achieve an application of 0.70 in (17.78 mm). Center pivot speed cannot exceed 100%.

VRI-S Screen

Use the Options VRI-S screen to enable the Variable Rate Irrigation Speed (VRI-S) control feature, view the prescriptions, and add sectors.

1. Press **OPTIONS**, **8**, **7** for VRI-S. See Figure 86-1.

```
0 EXIT          3 START    $ 6 MODULE
1 END-GUNS     4 STOP$    7 VRI
2 FOR/REV-POS  5 CYCLE$
ENTER MODULE NUMBER >
```

Figure 86-1

VRI-S ON/OFF

To turn the VRI-S feature on or off:

2. Press **OPTIONS**, **8**, **7**, **1** for the VRI-S On/Off screen. See Figure 86-2.

```
0 EXIT          3 VIEW PRESCRIPTION
1 VRI ON/OFF    4 ADD SECTOR
2 NA
PRESS NUMBER >
```

Figure 86-2

3. Press **1** for ON or **0** for OFF. The system default is OFF. See Figure 86-3.

```
0 EXIT          3 VIEW PRESCRIPTION
1 VRI ON/OFF    4 ADD SECTOR
2 NA
VRI (OFF) 1..ON 0..OFF >
```

Figure 86-3

4. Enter the prescription number to use with VRI-S. See Figure 86-4.

- There are five default prescriptions set from 0 to 360 degrees with a depth multiplier of 100%.
- Other prescriptions can be uploaded to the control panel to replace the default prescriptions. Up to five prescriptions can be stored.

```
0 EXIT          3 VIEW PRESCRIPTION
1 VRI ON/OFF    4 ADD SECTOR
2 NA
USING PRESCRIPTION # 1-5 (1) >
```

Figure 86-4

5. Press **ENTER**.

```
0 EXIT          3 VIEW PRESCRIPTION
1 VRI ON/OFF    4 ADD SECTOR
2 NA
PRESS NUMBER >
```

```
0 EXIT          3 VIEW PRESCRIPTION
1 VRI ON/OFF    4 ADD SECTOR
2 VRI-Z SPD CNTRL
PRESS NUMBER >
```

Figure 86-5

NOTE

- When VRI-S is turned on, Cruise Control is automatically disabled.
- The VRI On/Off screen functions as a VRI-S control option screen unless VRI-Zone protocol has been enabled.
- When the VRI-Zone protocol has been enabled, the VRI On/Off screen functions as a VRI-Zone Control option screen and "VRI-Z SPD CNTRL" is shown on the options VRI menu screen. See Figure 86-5.

VRI Speed Control Control Panel Display

Indication that VRI-S is enabled (ON), or running is shown on the control panel Status screen as described below:

- When VRI-S is enabled and ON on the Options screen:
 - » *VRI-S" is displayed on the Status screen when water is set to ON. See Figure 87-1.
 - » If RESTART is also displayed, "VRI-S" cycles with "RESTART" on the Status screen. See Figure 87-1.
 - » "ADJ 00%" and "0.00 IN" cycle and replace "0.00 HR" (hours per revolution) on the status screen. See Figure 87-1.
 - VRI is not displayed on the Status screen:
 - » When water is set to OFF, even when a VRI-S prescription is enabled (ON).
- or
- » When VRI-S prescription is disabled (OFF).

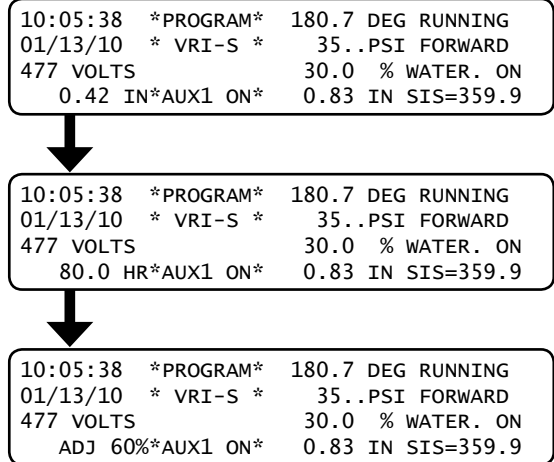

Figure 87-1

Options

VRI Speed Control

View Prescription

Use to review all prescription depth multiplier settings by degree/viewed position.

1. Press **OPTIONS**, **8**, **7**, **3** for the Prescription # screen. See Figure 88-1.

Initially, each of the five prescription depth multiplier settings are shown for the current pivot position.

2. To view each of the five prescription depth multiplier settings for a different position, use the UP or DOWN arrow to increase or decrease the viewed position by one degree. Holding the arrow increments the viewed position by five degrees every two seconds.
3. Press **ESC** to exit the VRI-S screen.

```
PIVOT POS (000) VIEWED POS (000)
1:100 2:100 3:100 4:100 5:100
PRESS UP OR DOWN TO CHANGE POSITION
PRESS ESC TO EXIT
```

Figure 88-1

Add Sector

To change or set sector positions and depth multipliers of any prescription:

1. Press **OPTIONS**, **8**, **7**, **4** for the Add Sector screen. See Figure 88-2.

2. Enter the prescription number (1-5), and press **ENTER**. See Figure 88-2.

3. Enter the left angle of the sector, and press **ENTER**. See Figure 88-3.

The left angle value is rounded down to the nearest even number. Example: A left angle of 181° is rounded down to 180°.

4. Enter the right angle of the sector, and press **ENTER**. See Figure 88-4.

The right angle value is rounded up to the nearest even number. Example: A left angle of 195° is rounded up to 196°.

5. Enter the depth multiplier (0% to 100%), and press **ENTER**. See Figure 88-5.

6. Press **ENTER** to SAVE changes or press **ESC** to CANCEL and exit to VRI-S screen. See Figure 88-6.

```
0 EXIT                3 VIEW PRESCRIPTION
1 VRI ON/OFF         4 ADD SECTOR
2 NA
ENTER PRESCRIPTION # 1-5 (1) > 2
```

Figure 88-2

```
0 EXIT                3 VIEW PRESCRIPTION
1 VRI ON/OFF         4 ADD SECTOR
2 NA
ENTER LEFT ANGLE > 25
```

Figure 88-3

```
0 EXIT                3 VIEW PRESCRIPTION
1 VRI ON/OFF         4 ADD SECTOR
2 NA
ENTER RIGHT ANGLE > 65
```

Figure 88-4

```
0 EXIT                3 VIEW PRESCRIPTION
1 VRI ON/OFF         4 ADD SECTOR
2 NA
ENTER DEPTH MULTIPLIER > 50
```

Figure 88-5

```
PRESCRIPTION #: 2
LEFT: 25    RIGHT: 65
DEPTH MULTIPLIER: 50 %
PRESS ENTER TO SAVE, ESC TO CANCEL >
```

Figure 88-6

Position Values

VRI-S works with Resolver, GPS, or Runtime Positioning.

- If GPS is not activated, position values are provided by the resolver.
- If GPS is activated, position values are provided by the GPS receiver. When there is no GPS signal the position resorts to using a backup, either Runtime or Resolver. An E18 error is recorded.

VRI-Zone Control

The VRI-Zone (VRI-Z) Control option uses mapping software and hardware to divide the irrigation machine sprinklers and the field into sectors/sprinkler zones that relate to the sectors on a sprinkler map. Each sector/sprinkler zone has an ID number associated with a VRI tower box valve that controls one or more sprinklers. There can be up to 30 sectors/sprinkler zones.

Each VRI tower box can support up to two sectors/sprinkler zones. Each VRI tower box OEM PLC modem card (OPMC) has an ID number. There can be up to 15 VRI tower boxes.

When the Pro2 control panel safety circuit is complete, the OEM PLC Modem Card (OPMC) in each VRI tower box powers up and begin receiving information from the control panel. As the machine runs, each sector/sprinkler zone is pulsed on and off based on its cycle time and percent ON setting (duty cycle).

At periodic intervals, the Pro2 control panel uses the sprinkler map along with the current resolver angle, GPS coordinates, or run time to determine the percent ON for each sector/sprinkler zone. It then sends a set sprinkler message with the current percent ON for each sector/sprinkler zone along with the current cycle time to the OPMC boards. Set sprinkler messages are sent out at least once every minute without GPS or once every two minutes with GPS.

VRI-Zone Screen

Use the Options VRI menu to enable VRI-Zone, VRI-Zone speed control feature, view the map, adjust parameters, and add sectors.

1. Press **OPTIONS**, **8**, **7** to access the VRI-Zone options menu screen. See Figure 89-1.

```

0 EXIT          3 START$    6 MODULE
1 END-GUNS     4 STOP$     7 VRI
2 NA           5 CYCLE$
PRESS NUMBER >
    
```

Figure 89-1

VRI-Zone ON/OFF

After the control panel has been set up, the VRI-Zone option can be turned ON or OFF by doing the following:

1. Press **OPTIONS**, **8**, **7**, **1** for the VRI ON/OFF screen. See Figure 89-2.
2. Press **1**..ON or **0**..OFF. See Figure 89-3.

```

0 EXIT          3 VIEW PRESCRIPTION
1 VRI ON/OFF   4 ADD SECTOR
2 VRI-Z SPD CNTRL
PRESS NUMBER >
    
```

Figure 89-2

NOTE

- When VRI-Zone is turned on, cruise control is automatically disabled.
- When VRI-Zone protocol has been enabled, the VRI ON/OFF screen functions as a VRI-Zone Control option screen, and "VRI-Z SPD CNTRL" is shown on the options VRI Menu screen. See Figure 89-4.

```

0 EXIT          3 VIEW PRESCRIPTION
1 VRI ON/OFF   4 ADD SECTOR
2 VRI-Z SPD CNTRL
VRI (OFF) 1..ON 0..OFF >
    
```

Figure 89-3

```

0 EXIT          3 VIEW PRESCRIPTION
1 VRI ON/OFF   4 ADD SECTOR
2 NA
PRESS NUMBER >
    
```

```

0 EXIT          3 VIEW PRESCRIPTION
1 VRI ON/OFF   4 ADD SECTOR
2 VRI-Z SPD CNTRL
PRESS NUMBER >
    
```

Figure 89-4

Options

VRI-Zone Control

VRI-Zone Speed Control Feature

The VRI-Zone speed control feature speeds up the machine if, in a given sector, all the duty cycles are less than 100%. When VRI-Zone is enabled and on, and Speed Control is on, the HOURS PER REV on the status screen is not valid, so ADJ. % is displayed in its place. See Figure 90-1.

```

10:05:38 *PROGRAM* 180.7 DEG RUNNING
01/13/10 * VRI-Z * 35. .PSI FORWARD
484 VOLTS 30.0 % WATER. ON
ADJ %*AUX1 ON* 0.83 IN SIS=359.9
    
```

Figure 90-1

VRI-Zone Speed Control ON/OFF

Turn VRI-Zone speed control on or off by doing the following:

1. Press **OPTIONS**, **8**, **7**, **2** for the VRI-Zone Control ON/OFF Screen. See Figure 90-2.
2. Press **1** for ON or **0** for OFF.

```

0 EXIT 3 VIEW PRESCRIPTION
1 VRI ON/OFF 4 ADD SECTOR
2 VRI-Z SPD CNTRL
SPEED CONTROL (ON) 1. .ON 0. .OFF
    
```

Figure 90-2

Status Screen

When VRI-Zone control (VRI-Z) is enabled and on on the options VRI-Zone screen, *VRI-Z* is displayed on the Status screen. If Restart is also on, *VRI-Z* cycles with "RE-START" on the status screen. See Figure 90-3.

When VRI-Zone speed control is on on the options VRI-Zone screen "ADJ 00%" replaces "0.00 HR" (hours per revolution) on the Status screen. See Figure 90-3.

```

10:05:38 *PROGRAM* 180.7 DEG RUNNING
01/13/10 * VRI-Z * 35. .PSI FORWARD
484 VOLTS 30.0 % WATER. ON
0.42 IN*AUX1 ON* 0.83 IN SIS=359.9
    
```

```

10:05:38 *PROGRAM* 180.7 DEG RUNNING
01/13/10 * VRI-S * 35. .PSI FORWARD
484 VOLTS 30.0 % WATER. ON
80.0 HR*AUX1 ON* 0.83 IN SIS=359.9
    
```

```

10:05:38 *PROGRAM* 180.7 DEG RUNNING
01/13/10 * VRI-S * 35. .PSI FORWARD
484 VOLTS 30.0 % WATER. ON
ADJ 60%*AUX1 ON* 0.83 IN SIS=359.9
    
```

Figure 90-3

Irrigation Prescription

A prescription is created using a computer and the Prescription software. See Figure 90-4.

The prescription can have up to 30 zones, each with a resolution of 2 degrees. The Percent ON values in the sprinkler map can be set from 0 to 100 percent in five percent steps.

NOTE

- A good understanding of the overall hydraulics of the center pivot, pipeline, if any, and pump is necessary to ensure equipment is not damaged by shutting off too many zones at once, thereby decreasing flow to less than the minimum flow rate.
- Most pumps experience an increase in pressure as the flow is decreased. The minimum flow rate must be determined in order to calculate the maximum changes that can be made.
- A variable speed pump is a good option.
- Contact your Valley dealer if you have questions.

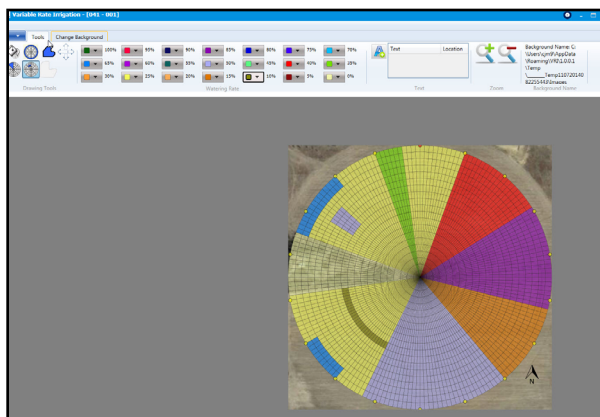

Figure 90-4 Example prescription as shown using VRI prescription software. The prescription in graphic form is not seen on the Pro2 control panel.

VRI Zone Control

View Prescription

To display the duty cycle for each sprinkler zone at a specific position on the map:

1. Press **OPTIONS**, **8**, **7**, **3** for the Map screen.

Initially the current Pivot Position is shown in both the Pivot Position field and Viewed Position field. See Figure 91-1.

Adjusting the viewed position:

- Use the **↑**, **↓** to increase/decrease the viewed position by one degree.
- Holding the arrow increments the viewed position by five degrees per second.

Viewing the duty cycles:

- Press **FORWARD** to view the next sprinkler zone duty cycle for the viewed position. See Figure 91-2.

or

- Press **REVERSE** to view the previous sprinkler zone duty cycle for the viewed position. See Figure 91-3.

2. Pressing **ESC** exits to the VRI screen.

Prescription Upload Methods

Listed below are products along with several methods for uploading prescriptions to a Pro2 control panel based on the product being used.

Hardware and Software Requirements

- BaseStation2-SM software version 8.3.4 or above (VRI)
- TrackerSP software:
 - » GPRS version 12 (Compatible with VRI software in Pro2 control panels)
 - » CDMA version 15 (Compatible with VRI software in Pro2 control panels)
- VRI Prescription Software including Prescription Loader: Upload or save a prescription created with the VRI prescription software program.
 - » Upload a prescription directly to a Pro2 control panel through a serial cable connection with a personal computer.
 - » Save a prescription to the C:\Program Files\ValleyBase\VRI folder on the computer hard drive for use with BaseStation2-SM.
- BaseStation2-SM: Access a prescription saved by Prescription Loader to the C:\Program Files\ValleyBase\VRI folder on the computer hard drive for upload to a Pro2 or Select2 control panel through a data radio or phone connection. 300 and 1200 baud radios are not recommended.
- TrackNET web site: Access a prescription created with the VRI prescription software from the C:\VRI\RTU ID folder on the computer hard drive for upload through a wireless connection to a Pro2 control panel with TrackerSP.

```
PIVOT POS (000)  VIEWED POS (000)
1:100  3:100  5:100  7:100  9:100
2:100  4:100  6:100  8:100  10:100
PRESS REV..BACK  FOR..NEXT
```

Figure 91-1

```
PIVOT POS (000)  VIEWED POS (000)
3:100  5:100  7:100  9:100  11:100
4:100  6:100  8:100  10:100  12:50
PRESS FOR..BACK  REV..NEXT
```

Figure 91-2

```
PIVOT POS (000)  VIEWED POS (000)
21:100  23:100  25:100  27:100  29:100
22:100  24:100  26:100  28:100  30:50
PRESS REVERSE..BACK  FORWARD..NEXT
```

Figure 91-3

Options

VRI-Zone Control

Add Sector

Used to add or change the sector position and duty cycle of the prescription while in the field.

1. Press **OPTIONS**, **8**, **7**, **4** for the add sector screen. See Figure 92-1.
2. Press the sprinkler zone number to add. Example: Press **3**, **0** to enter sprinkler zone 30. See Figure 92-1.
3. Press the 3-digit left angle number. Example: Press **1**, **8**, **0** for 180. See Figure 92-2.
4. Press the 3-digit right angle number. Example: Press **1**, **9**, **5** for 195. See Figure 92-3.
5. Press the duty cycle number in 10% increments only. Example: For a 50% duty cycle press **5**, **0**, **ENTER**. See Figure 92-4.
6. Press **ENTER** to SAVE or **ESC** to CANCEL and exit to the Variable App screen. See Figure 92-5.

```
0 EXIT                3 VIEW PRESCRIPTION
1 VRI ON/OFF          4 ADD SECTOR
2 VRI-Z SPD CNTRL
ENTER SPRINKLER BANK (1-30) >
```

Figure 92-1

```
0 EXIT                3 VIEW PRESCRIPTION
1 VRI ON/OFF          4 ADD SECTOR
2 VRI-Z SPD CNTRL
ENTER LEFT ANGLE >
```

Figure 92-2

```
0 EXIT                3 VIEW PRESCRIPTION
1 VRI ON/OFF          4 ADD SECTOR
2 VRI-Z SPD CNTRL
ENTER RIGHT ANGLE >
```

Figure 92-3

```
0 EXIT                3 VIEW PRESCRIPTION
1 VRI ON/OFF          4 ADD SECTOR
2 VRI-Z SPD CNTRL
ENTER DUTY CYCLE >
```

Figure 92-4

```
SPRINKLER BANK: 30
LEFT: 180      RIGHT: 196
DUTY CYCLE: 50 %
PRESS ENTER TO SAVE, ESC TO CANCEL
```

Figure 92-5

System Shutdown

The Pro2 monitors the system pressure and flow rate. If the system pressure exceeds the user-entered maximum system pressure for three seconds, the system shuts down. Likewise, if the flow rate is less than the user-entered minimum flow rate after the system operating pressure is above the low pressure limit, the system shuts down. A system fault occurs in the event of a shutdown.

Re-synchronize Valve Duty Cycle

When the valve re-synchronize pressure is reached, the duty cycles of all sprinkler zones starts over. All the odd numbered zones start on the OFF part of the cycle, and all even numbered zones start on the ON part of the cycle.

Position Values

VRI-Zone Control works with Resolver, GPS, or Runtime Positioning:

- If GPS is not activated, position values are provided by the resolver.
- If GPS is activated, position values are provided by the GPS receiver. But, when there is no GPS signal, the position resorts to using backup, either Runtime or Resolver. An E18 error is recorded.

Adjustments

Adjustments to the VRI-Zone control settings can be made at the control panel.

- Left angle, right angle and duty cycle of a sector/sprinkler zone adjustments, use: **OPTIONS / OTHER / VRI / ADD SECTOR.**
- Minimum cycle time of a valve adjustment, use: **SYSTEM / CONSTANTS / OTHER / OTHER / OTHER / VRI-ZONE / MIN CYCLE TIME.**
- Current minimum flow rate adjustment, use: **SYSTEM / CONSTANTS / OTHER / OTHER / OTHER / VRI-ZONE / MIN FLOW RATE.**
- Maximum pressure adjustment, use: **SYSTEM / CONSTANTS / OTHER / OTHER / OTHER / VRI-ZONE / MAX PRES.**
- Low pressure limit adjustment, use: **SYSTEM / CONSTANTS / LOW PRES.**
- To review flow rate information, use: **SYSTEM / DATA / FLOW/WIND/TEMP.**

VRI-Zone Control

Overview

The pages in this section provide a brief description of the Valley Variable Rate Irrigation (VRI) components and controls.

VRI Tower Box

Each VRI tower box contains an OEM PLC Modem Card (OPMC) and two solenoid valves. See Figure 93-1.

The Pro2 control panel sends messages to the OPMC that provide the current percent ON for control of each solenoid valve. VRI tower boxes are usually installed on the span pipe close to the drive unit.

Water Filter

The water filter filters water going to the solenoid valves in the tower box. See Figure 93-1.

Each water filter supplies water to both solenoids' valves on one VRI tower box.

Sprinkler Valve

One or more Aquamatic sprinkler valves are opened and closed by one solenoid valve in the VRI tower box. A plastic tube connects each Aquamatic sprinkler valve to a solenoid valve. See Figure 93-2.

The Aquamatic sprinkler valve used in the VRI application does not have a drain.

A typical plumbing configuration for regions where the temperature during the winter months drops below 40°F (4°C), and/or the growing season is six months is shown in Figure 93-2.

- The valve is mounted horizontally which allows water to drain out of the valve and plumbing reducing the possibility of damage due to freezing. See Figure 93-2.

Other plumbing configurations that might be used in regions where the temperature during the winter months stays above 40°F (4°C) are shown in Figure 93-3.

- The valve is mounted vertically which does not allow water to drain out of the valve or U-pipe. If temperatures drops below 40°F (4°C), turn the VRI option OFF and run the machine with water, this opens the valves (which can be visually inspected) to drain water and reduce the possibility of damage due to freezing. See Figure 93-3.

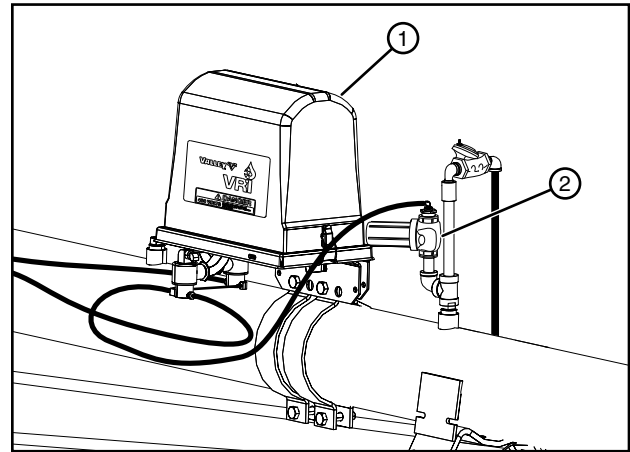

Figure 93-1 1. VRI Tower Box
2. Water Filter

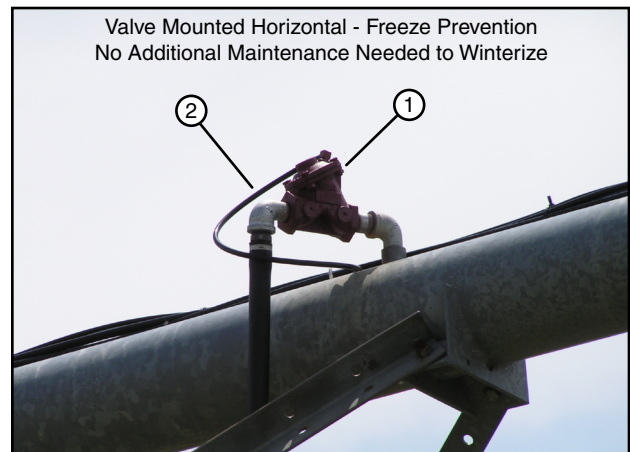

Figure 93-2 1. Aquamatic Valve
2. Plastic Tube

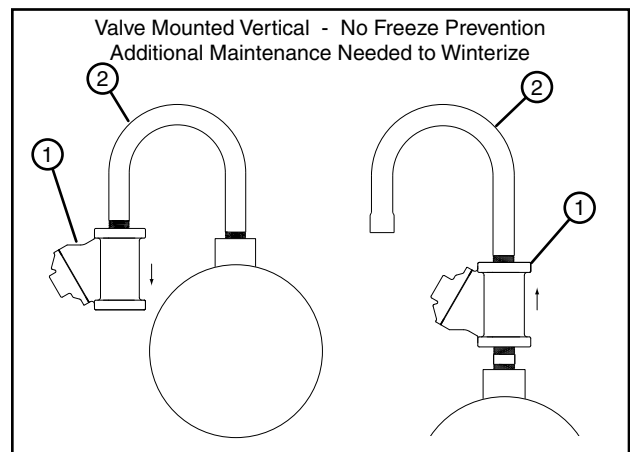

Figure 93-3 1. Aquamatic Valve
2. U-Pipe

Options

VRI-Zone

Overview

Data Port

The Data Port option can be used when uploading a VRI prescription to the Pro2 control panel from a computer running the prescription software. See Figure 94-1.

Stand Pipe Option

The Stand Pipe Option is used to reduce OFF duty cycle lag time in extreme applications where it takes more than a few seconds for sprinkler valves in a specific zone to close. See Figure 94-2.

The ball valve on the bottom of the stand pipe must be closed during operation.

In regions where the temperature during the winter months drops below 40°F (4°C), and/or the growing season is six months or less, drain the stand pipe at the end of season.

NOTE: This option is typically not used in normal applications.

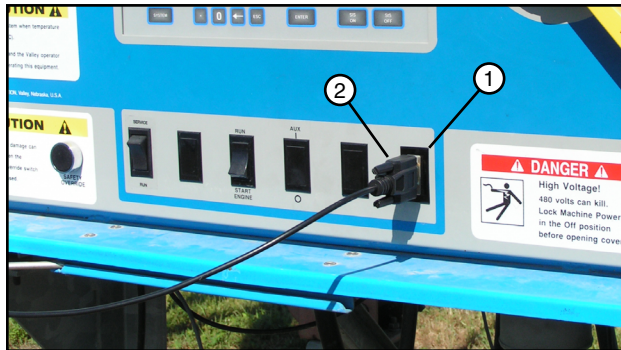

Figure 94-1 1. Data Port
2. Serial Cable

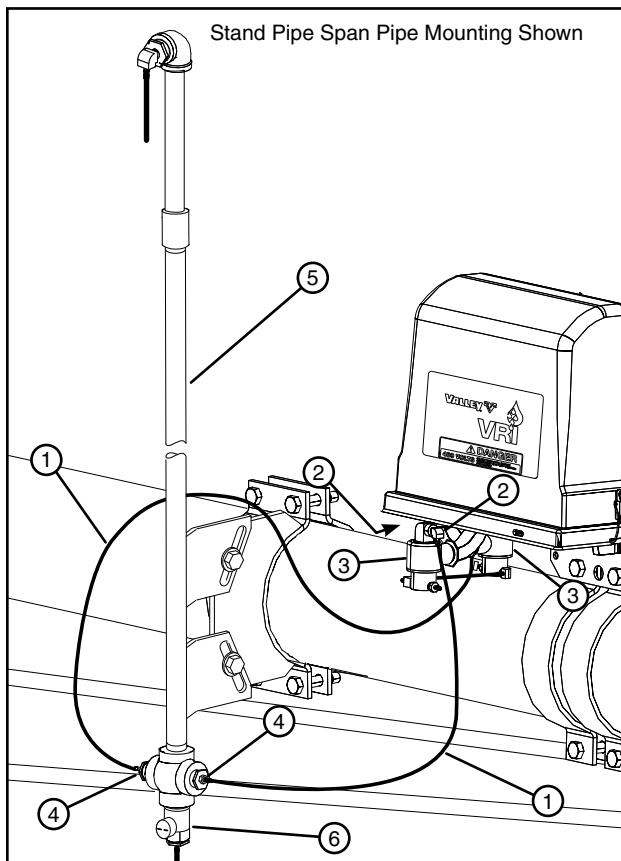



Figure 94-2 1. Plastic Tubing 2. Exhaust Port 3. Solenoid 4. Fitting 5. Stand Pipe 6. Ball Valve

Diagnostics Screen

The Diagnostics section provides an overview of the use of the diagnostic features incorporated in the control panel. Diagnostics aid in identifying machine failures, troubleshooting, and correcting problems.

0 EXIT	3 CRUISE CTL	6 NA
1 SYSTEM FAULTS	4 VRI-Z DIAG	7 NA
2 ERROR LOG	5 PLC ERRORS	
PRESS NUMBER >		

Figure 95-1

1. Press  to view the Diagnostics screen. See Figure 95-1.

System Faults

System Faults are failures that shut the machine down. Any item showing FAULT on the system faults screen has caused the machine to shut down. The faults that can be indicated on the System Fault screen are shown in Figure 95-2. Refer to the Troubleshooting section for possible causes and corrective actions.



SYSTEM POWER FAULT	Voltage has fallen below the low voltage limit for more than 15 seconds, or power was lost while the machine was running.
SYSTEM SAFETY FAULT	Caused by a break in the safety return circuit that lasted longer than three seconds.
LOW PRESSURE FAULT	The pressure fell below the low pressure limit, or the Pressure Delay is not a sufficient amount of time to build pressure in the machine after it is started.
HIGH PRESSURE FAULT	With VRI-Zone on, the pressure went above the high pressure limit for more than three seconds.
WATER TIMER FAULT	The machine shut down because it was moving too slowly, thereby applying too much water.
COMMAND FAULT	The machine was commanded to stop by one of the following: 1) The STOP key was pressed. 2) An autostop condition occurred at the end-of-field stop. 3) A programmed STOP command was executed.
STOP-IN-SLOT (SIS) FAULT	The machine was shut down by the Stop-In-Slot.
PROGRAM FAULT	The machine was shut down because a Step program stopped the system.
AUTOSTOP FAULT	An autostop condition occurred at the end-of-field stop.
BBRAM FAULT	An attempt was made to start the machine when error E01 was displayed on the status screen.
FLOW FAULT	With VRI-Z on, the flow rate has fallen below the amount set in the FLOWMETER GAL/PULSE field.
FOR/REV FAULT	Both the forward and reverse sensor relays were on for more than 15 seconds while the system was running or waiting.
TIRE PRESSURE	Tire pressure shutdown was turned on and one or more tires had low pressure.
WIND FAULT	The machine shut down because the wind speed reached the high wind limit. The wind speed indicator is an option. WIND is only displayed on the system faults screen when wind is turned ON.
TEMPERATURE FAULT	The machine shut down because the temperature fell below the low temperature limit.
RAIN FAULT	The machine shut down because the rain limit was exceeded in the rain window time period.
DAILY OPS FAULT	The daily operations program shut the machine down because it is not allowed to run between a certain time period, DAILY OPS is only displayed on the system faults screen when Daily Ops is turned ON.
NO ACK	No Acknowledge is enabled and the BaseStation did not acknowledge the message.
RELAY COM FAULT	There is a hardware or software communication problem between the Pro2 module and the electrical relay board within the control panel.
GPS COM FAULT	When GPS is selected as a protocol and the system shuts down due to no communication with GPS for a user-specified amount of time, when shut down of GPS signal loss is ON, or while the system was running or waiting.
GPS LOCK FAULT	When GPS is selected as a protocol and the System shuts down due to GPS signal loss for a user-specified amount of time, or when shut down of GPS signal loss is ON, or while the system is running or waiting.
BOUNDARY FAULT	The machine shut down because it traveled beyond the forward or reverse Position angles.

Figure 95-2

Diagnostics

Viewing System Faults

System faults are displayed on the main screen and under Diagnostics. To view the System Faults screen under Diagnostics, do the following:

1. Press ,  to display the System Faults screen. See Figure 96-1.

When a recognized fault causes the machine to shut down, FAULT is displayed next to the item responsible for the shutdown.

FAULT is automatically cleared the next time the machine is run successfully.

SYSTEM POWER	OK	SIS	OK
SYSTEM SAFETY	OK	WIND	OK
PRESSURE	OK	DAILY OPS	OK
COMMAND	OK	RELAY COM	FAULT

Figure 96-1

Status Screen Diagnostics

If a failure occurs, an error code appears on the status screen. If more than one error has occurred, the errors that have occurred will sequence between each other every second. See Figure 96-2.

NOTE: Viewing the error log screen clears the error codes from the Status screen.





03:00:00		180.0 DEG RUNNING
06/12/14		33. .PSI FORWARD
477 VOLTS	E05	50.0 % WATER. ON
48.0 HR		0.50 IN SIS= OFF

Figure 96-2 1. Error Code

Clearing an Error Code

To view and clear an error code from the status screen, do the following:

1. Press , and  to display the Error Log screen. See Figure 96-3.
2. Press  and Search backward to view an error code. Viewing an error code clears the error code from the status screen.

0	EXIT
1	SEARCH BACKWARD
2	SEARCH FORWARD
	PRESS NUMBER >

Figure 96-3

Error Codes

A list of possible error codes is shown in the table below. Refer to the Troubleshooting section for possible causes and corrective action.

ERROR CODES	DESCRIPTION
E01	BBRAM - Checksum failed at power up.
E02	EEPROM - Checksum failed at power up.
E03	UNIT RESETS - This is logged when the software resets.
E04	POWER DROP - Power dropped below low voltage limit.
E05	SYSTEM SAFETY - Possible tower misalignment, drive unit may be stuck.
E06	PUMP SAFETY - Pressure too low after pressure delay.
E07	PRESSURE SENSOR - Out of range high, check connection.
E08	PRESSURE SENSOR - Out of range low, check connection.
E09	PRESSURE SENSOR - Pressure high with pump off, check connection.
E10	PRESSURE SENSOR - Mechanical switch could be stuck.
E11	RESOLVER - Angle jumping around. Lube J pipe.
E12	E12 RESOLVER - Out of range high, check for loose or shorted wires.
E13	KEYPAD - Possible key stuck, check keypad connection.
E14	FWD/REV SENSE - Possible short, check wiring.
E15	UNDERWATER ERROR - Check for induced voltages and % timer connections.
E16	NOT AVAILABLE
E17	NOT AVAILABLE
E18	GPS communications error, check GPS connection and power.
E19	GPS SIGNAL LOSS, check for clear path above antenna.
E20	DGPS SIGNAL LOSS, check for clear path above antenna.
E21	LOW FLOW
E22	HIGH PRESSURE
E23	PLC COMMUNICATIONS ERROR. (GPS V2 Only)
E24	RESYNC valve duty cycle due to pressure.
E25	GPS COORDINATES OUT OF RANGE, check distance to GPS or for crosstalk.
E26	LOW TIRE PRESSURE
E27	TPMS COMMUNICATIONS ERROR

Diagnostics

Error Logs

For each error code there is an error log.

When an error occurs, information about the error, including the first time and date, last time and date, and total count of all times that the error occurred is recorded in the error log. See Figure 98-1.

Viewing an Error Log

To view an Error Log, do the following:

1. Press **DIAGNOSTICS**, **2**, **1** to display the E01 Error Log screen. See Figure 98-2.

NOTE: Viewing the error log screen clears the error codes from the Status screen.

2. Locate the desired error log:
 - Press **1** to search backward through the Error Logs.
 - Press **2** to search forward through the Error Logs.
3. Press **ESC** to return to the menu. Press **ESC** a second time to return to the main panel display.

Resetting an Error Log to Zero

To reset an Error Log to zero, do the following:

1. Press **DIAGNOSTICS**, **2**, **1** to display the E01 Error Log screen. See Figure 98-3.
2. Locate the desired error log screen to reset. See Figure 98-4.
 - Press **1** to search backward through the Error Logs.
 - Press **2** to search forward through the Error Logs.
3. Press **←** two times.

The count is reset to zero and the first and last occurrences are set to the current time and date. See Figure 98-5.

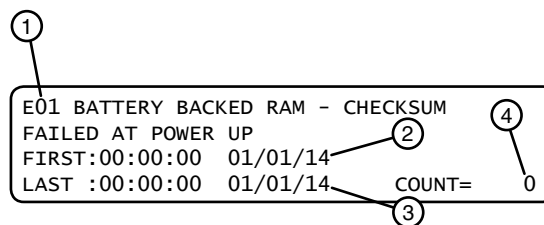

Figure 98-1 1. Error Code
2. First Occurrence Time and Date
3. Last Occurrence Time and Date
4. Total Occurrences

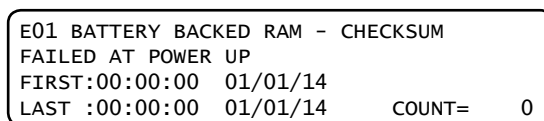

Figure 98-2

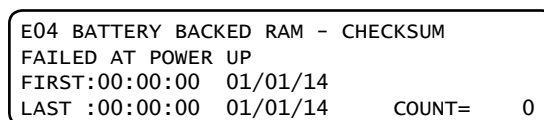

Figure 98-3

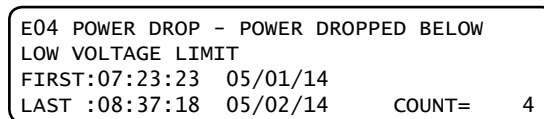

Figure 98-4 Selected Error Log

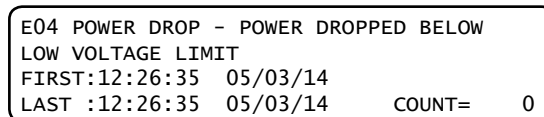



Figure 98-5

Program Screen

From the Program screen the user can choose to create, edit, store, run, review, and erase Step or Sector programs.

1. Press  to view the Program screen. See Figure 99-1.
2. Press  STEP PROGRAMS.

```
0 EXIT
1 STEP PROGRAMS
2 SECTOR PROGRAMS
PRESS NUMBER >
```

Figure 99-1

Step Programs

Use Step programs to execute one or more commands, options, or a stored Step program based on a selected programming condition. The user can program up to 17 step programs, with a maximum of 9 steps in each. The steps in a program are executed in numerical order.

Program numbers 18, 19, and 20 are used for the START\$, STOP\$, and CYCLE\$ programs.

Up to all twenty programs can be run, or can be current at the same time. If more than one program is current, the computer continuously scans all of the current programs and looks for a step with a condition which is met. If the same condition in two or more step programs is met at the same time, the step in the program that was loaded last is executed.

When the last step of a program is complete, the program is deleted from the current memory, but remains in the stored memory.

Step Program Functions

- RUN STORED - Use to load stored step programs in current memory for execution.
- CREATE NEW - Use to write new step programs.
- REVIEW CURRENT - Use to review the current step program.
- REVIEW STORED - Use to review and delete stored step programs which can be recalled for execution
- EDIT - Use to edit stored step programs.
- ERASE - Use to erase stored step programs from memory.

Programming Conditions

- TIME - Execute commands based on the date and time of day, and time of day and day of the week.
- POSITION - Execute commands based on the position of the machine.
- PRESSURE - Execute commands based on water pressure.
- DELAY - Execute commands based on a time delay of up to 60,000 seconds (16.67 hours) or 60,000 minutes (41.67 days).
- FOR/REV - Execute commands based on the direction of the machine movement.
- Other Conditions - Refer to Other Programming Conditions on the next page for more information.

Available Commands

- Percent
- Depth
- Start/Stop
- Forward/Reverse
- Water ON/OFF
- SIS ON/OFF
- End Guns Enable/Disable
- Cruise Control Enable/Disable
- VRI Enable/Disable
- Trigger a Logging Event

Available Options

- Auxiliary 1 ON/OFF
- Auxiliary 2 ON/OFF
- Start\$
- Stop\$
- Cycle\$
- Module
- Auto Reverse (when enabled)
- Auto Restart
- Adjust % Timer or Depth by a %

Stored Program

- Any stored Step program can be run from the last step of another step program. Refer to the RUN PROGRAM command in this section of this manual.
- Any stored Step program can be started from any step in the program.

Step Programs

Other Programming Conditions

Selecting OTHER from the Create New screen offers the other programming conditions listed below:

1. Press **PROGRAM**, **1**, **2**, **6** to display the other condition screens. See Figure 100-1.

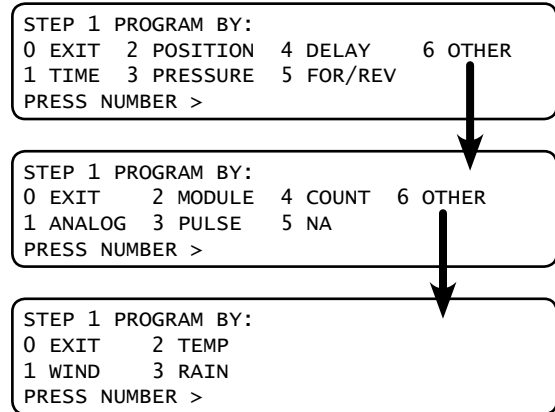

Figure 100-1

Analog

This programming condition is based on an analog voltage being higher or lower than the set value. This condition can only be used if an external device with an analog voltage output is connected to the Pro2 control panel. See Figure 100-2.

Analog Number	Description
0	Monitors Resolver Signal X
1	Monitors Resolver Signal Y
2	Not Used
3	Monitors Pressure Transducer Voltage

Analog Number	Description
4	Monitors Machine Voltage
5	Monitors Voltage to Pressure Transducer
6	Monitors Resolver Bias Reference Voltage
7 - 11	Not Used

Figure 100-2 Analog Voltage Connections

Module

This programming condition is based on the condition, either ON/Closed or OFF/Open, of a control relay in the Pro2 control panel. Listed below are the available modules/relays. See Figure 100-3.

MODULE NUMBER	RELAY NUMBER	FUNCTION DESCRIPTION	RELAY BOARD TERMINAL
0	K1	Safety Out	J5-1
1	K2	Percent Timer	J5-2
2	K7	End Gun	J13-5
3	K8	Wide Boundary	J13-6
4	K6	Pump Safety	J13-1, 2, 3
5	K9	Alarm	J6-1, 2, 3
6	K12	Auxiliary 1 Output	J7-1, 2
7	K13	Auxiliary 2 Output	J7-3, 4
8	K4	Contactor Enable	J5-5, 6
9	K3	Direction (Forward=ON, Reverse=OFF)	J5-3, 4
10	D03	Control Panel Backlight	J15-5
11	D02	TTL Output 2	J15-4

MODULE NUMBER	RELAY NUMBER	FUNCTION DESCRIPTION	RELAY BOARD TERMINAL
12	D01	TTL Output 1	J15-3
13	R01	Low Side 1	J15-1
14	R02	Low Side 2	J15-2
15		Not Used	
16		Remote Start	J6-5
17		Pressure Switch	J6-4
18	K5	3 Second timer	
19	K15	Auxiliary 2 Input	J7-7, 8
20	K14	Auxiliary 1 Input	J7-5, 6
21	K10	Reverse Sense	J5-4
22	K11	Forward Sense	J5-3
23	K5	Safety Sense	J5-7
24		PC4/Rain Sense	J16-9
25		PC5	J16-10

Figure 100-3 Available Modules/Relays

Pulse

This programming condition is based on pulse rates of a counter being higher or lower than a set value. This condition can only be used if a device with a pulse output is connected to the Pro2 control panel.

Count

This programming condition is based on pulse counts being higher than a set value. This condition can only be used if a device with a pulse output is connected to the Pro2 control panel. See Figure 101-1.

Counter Number	Description	Relay Board Labels	Relay Board Terminal
0	Monitors Flow Meter	Pulse 1	J4-11
1	Monitors Wind Meter	Pulse 2	J4-12
2	Not Currently Used	N/A	N/A
3	Rain Sensor	3 PC4	J16-9
4	Not Currently Used	4 PC5	J16-10

Figure 101-1 Devices with Pulse Outputs

Wind

This programming condition is based on the wind speed being higher or lower than a set value. The minimum is 0 mph, and the maximum is 300 mph (482.8 km). This condition can only be used if a wind speed sensor is installed.

Temperature

This programming condition is based on the temperature being higher or lower than a set level. The minimum value is 14°F (-10°C) to 176°F (80°C). This condition can only be used if a temperature sensor is installed.

Rain

This programming condition is based on the rainfall being higher or lower than a set level. This condition can only be used if a rainfall sensor is installed.

Step Programs

Run Program Command

A stored Step program can be loaded and run from the last step within the same, or another Step program. It is recommended that the RUN PROGRAM command be the last command in the last step of the program.

This programming feature can be used to run the same program over, or run programs in a sequence. For example, if there are three stored programs that need to be run in sequence, the last step of program 1 would command program 2 to run. The last step in program 2 would command program 3 to run. And then, the last step in program 3 would command program 1 to run, starting the sequence over.

To add the RUN PROGRAM command to the last step in another program, follow the instructions below.

1. Press **PROGRAM**, **1**, **1** to display the Stored Programs screen. See Figure 102-1.
2. Select the program to run.
3. Press **ENTER** to add the RUN PROGRAM command as the last command of the step. See Figure 102-2.
4. Press **ENTER** to finish the program.

```
STORED PROGRAMS 1,2,3,4,  
ENTER PROGRAM NUMBER >
```

Figure 102-1

```
STEP 1 AT 180.0 DEGREES, WATER ON,  
FORWARD,RUN PROGRAM 2,  
ENTER COMMANDS, FINISHED..PRESS ENTER
```

Figure 102-2

```
0 EXIT          3 REVIEW CURRENT  6 ERASE  
1 RUN STORED   4 REVIEW STORED  
2 CREATE NEW   5 EDIT  
PRESS NUMBER > 1
```

Figure 102-3

```
STORED PROGRAMS 1,2,3,4,5,6,  
ENTER PROGRAM NUMBER > 6
```

Figure 102-4

```
STEP 1 AT:  0.0 DEGREES, FORWARD,  
WATER ON, DEPTH  1.00,  
START AT STEP 1?  1..YES 2..NO >
```

Figure 102-5

```
STEP 2 AT: 180.0 DEGREES, REVERSE,  
WATER ON, DEPTH  1.00,  
START AT STEP 2?  1..YES 2..NO
```

Figure 102-6

```
PROGRAM 6 LOADED  
AT STEP 2  
PRESS ANY KEY >
```

Figure 102-7

```
*** END OF PROGRAM STEPS ***  
PRESS ANY KEY >
```

Figure 102-8

Start at a Step

A stored Step program can be started at any given step in the program.

This programming feature can be used to run a program based on a unique situation in the field. For example, a machine is irrigating an area between 0° and 180° in forward and reverse. It happens that the machine is stopped at 180°, and you want it to return in reverse to 0°. You can tell the program to start at step 2 (REVERSE) instead of step 1 (FORWARD).

To start this example of a stored Step program at step 2, you would follow the instructions below.

1. Press **PROGRAM**, **1**, **1** for RUN STORED. See Figure 102-3.
2. Press the number of the program containing the step, followed by **ENTER**. See Figure 102-4.
3. Press **2** to answer NO to start at step 1. See Figure 102-5.

The system asks you if you want to start at step 2. See Figure 102-6.

4. Press **1** to choose YES.

A message is displayed stating that the program is loaded at step 2. See Figure 102-7.

If you had continued to choose NO until all steps had been displayed, the message in Figure 102-8 would be displayed.

Example Step Program Design Form

The Step Program Design Form is a useful tool when you are planning your Step program. It provides you with the ability to describe the conditions, commands, and options you want included in the program. Figure 103-1 below is an example of how the steps in Step programming could each be mapped out and described.

08/08/07
 3:00 AM
 Water ON
 1.00 inches
 Forward

Step Program Number 2
 Field ID 004

CONDITIONS	STEP NUMBER								
	1	2	3	4	5	6	7	8	9
TIME	08/08/07 3:00 AM								
POSITION		180	225	0					
PRESSURE									
DELAY									
FOR / REV									
OTHER CONDITIONS									
ANALOG									
MODULE									
PULSE									
COUNT									
WIND									
TEMPERATURE									
RAIN									
COMMAND KEYS									
WATER ON	X		X						
WATER OFF		X							
PERCENT		100							
DEPTH	1.00		0.75						
FORWARD									
REVERSE									
STOP-IN-SLOT ON									
STOP-IN-SLOT OFF									
START	X								
STOP				X					
OPTIONS									
AUX 1 ON / OFF									
AUX 2 ON / OFF									
START									
STOP									
CYCLE									
MODULE									
AUTO REVERSE									
AUTO RESTART									

Figure 103-1

Step Programs

Using Create New

To write a new Step Program, fill in a copy of the Step Program Design Form with conditions and commands for each step. Refer to the sample Step Program Design Form on the previous page. Blank forms are located in the Appendix. Using a completed design form, follow the steps below:

1. Press to display the Programs Selection screen. See Figure 104-1.
2. Press to select STEP PROGRAMS.
3. Press to select CREATE NEW. See Figure 104-2.
4. Select one of the following conditions for which to program.

```
0 EXIT
1 STEP PROGRAMS
2 SECTOR PROGRAMS
PRESS NUMBER >
```

Figure 104-1

NOTE: Selecting OTHER takes you to the next Conditions screen for more choices.

```
0 EXIT          3 REVIEW CURRENT  6 ERASE
1 RUN STORED   4 REVIEW STORED
2 CREATE NEW   5 EDIT
PRESS NUMBER >
```

Figure 104-2

Conditions Screen 1	Conditions Screen 2	Conditions Screen 3
<input type="button" value="1"/> TIME	<input type="button" value="1"/> ANALOG	<input type="button" value="1"/> WIND
<input type="button" value="2"/> POSITION	<input type="button" value="2"/> MODULE	<input type="button" value="2"/> TEMPERATURE
<input type="button" value="3"/> PRESSURE	<input type="button" value="3"/> PULSE	<input type="button" value="3"/> RAIN
<input type="button" value="4"/> DELAY	<input type="button" value="4"/> COUNT	
<input type="button" value="5"/> FORWARD or REVERSE	<input type="button" value="5"/> NA	
<input type="button" value="6"/> OTHER	<input type="button" value="6"/> OTHER	

5. Enter the value for the selected programming condition and press to retain the value.
6. Select the desired command(s), option(s) or program for this program step by pressing the desired command, option or program key(s). See Figure 104-3.
7. When finished entering command(s), option(s), or program press .
8. At the next step screen, do one of the following. See Figure 104-4.
 - Press EXIT.
 - Press PROGRAM FINISHED.
 - Press NEXT STEP to add another step to the program.

```
STEP 1 AT: RAIN HIGHER THAN 1.00 IN.
STOP
ENTER COMMANDS, FINISHED..PRESS ENTER
```

Figure 104-3

```
0 EXIT
1 PROGRAM FINISHED
2 NEXT STEP
PRESS NUMBER >
```

Figure 104-4

Using Create New (continued)

9. If PROGRAM FINISHED is selected, do one of the following. See Figures 105-1 and 105-2.

- Press **1** for SAVE PROGRAM.
 - » Select program number 1-17.
 - » Press **ENTER** to save the program.
- Press **2** for SAVE PROGRAM AND RUN.
 - » Select program number 1-17.
 - » Press **ENTER** to save and run the program.
- Press **3** for CANCEL PROGRAM to cancel the program.
- Press **4** for RUN THEN DELETE to run the program once and then delete it.

```

0 EXIT          3 CANCEL PROGRAM
1 SAVE PROGRAM 4 RUN THEN DELETE
2 SAVE PROGRAM AND RUN
PRESS NUMBER >
  
```

Figure 105-1

```

STORED PROGRAMS

PRESS NUMBER FROM 1 TO 17 TO SAVE
ENTER PROGRAM NUMBER >
  
```

Figure 105-2

Using Review Current

To review current Step programs that are running or will be executed as soon as their conditions are met, follow the steps below. All steps in a program can be reviewed while the program is running. As the running program is being reviewed, an asterisk (*) located in the lower left hand corner indicates the step that contains the next step to be being executed. Step program numbers are not displayed on the review current screen.

1. Press **PROGRAM**, **1**, **3** to display the Review Current screen. See Figure 105-3.

If a program is in current memory, the first step is displayed.

2. Press any key to advance to the next step.
3. At the last step, the Review Decision screen is displayed. Do one of the following. See Figure 105-4.

- Press **ENTER** for next,
 - » If another program is in current memory, the first step of that program is displayed.
 - » If no other programs are in current memory, the End of Current Programs screen is displayed. See Figure 105-5.

```

STEP 1 AT: 06/22/07 06:30:00, WATER ON,

PRESS ANY KEY >
  
```

Figure 105-3

```

STEP 5 AT: 359.9 DEGREES, STOP,

*ENTER..NEXT 1..DELETE ESC..EXIT >
  
```

Figure 105-4

```

*** END OF CURRENT PROGRAMS ***

PRESS ANY KEY >
  
```

Figure 105-5

- Press **1** to delete the program from the current memory. (Deleting a current program does not erase it from the stored program memory.
- or
- Press **ESC** to exit review current.

Step Programs

Using Review Stored

To review a Step program stored in memory, follow the steps below. All steps in a program can be reviewed while the program is running.

1. Press **PROGRAM**, **1**, **4** to display the Stored Programs screen. See Figure 106-1.
2. Enter the desired program number from the Stored Programs list at the top of the screen.
3. Press **ENTER** to confirm the program number selection, and step 1 of the program is displayed. See Figure 106-2.
4. Press any key to advance to the next step in the program.

```
STORED PROGRAMS 1, 2,  
  
ENTER PROGRAM NUMBER >
```

Figure 106-1

```
STEP 1 AT: 06/22/07 06:30:00, WATER ON,  
  
*PRESS ANY KEY >
```

Figure 106-2

Using Edit

To edit a Step program stored in memory, follow the steps below:

1. Press **PROGRAM**, **1**, **5** to display the Stored Programs screen. See Figure 106-3.
2. Enter the desired program number from the Stored Programs list at the top of the screen.
3. Press **ENTER** to confirm the program number selection, and step 1 of the program is displayed. See Figure 106-4.
4. Edit the program step, if desired.
 - If no changes are required, press **ENTER** to accept the step and display the Next Step screen.
 - If changes are required do one or more of the following:
 - » Press **←** to move the flashing cursor back through the step to change a command or condition. The complete step can be deleted by pressing the back space key. When the cursor reaches the date, the current screen disappears.
 - » Press **-** to erase the command or condition that the cursor is highlighting. Then, a new command can be added or other appropriate programming can be done.
 - » When done, press **ENTER** to accept the step.

```
STORED PROGRAMS 1, 2,  
  
ENTER PROGRAM NUMBER > 1
```

Figure 106-3

```
STEP 1 AT: 06/22/07 06:30:00, WATER ON,  
  
ENTER..ACCEPT BS..CURSOR -..DEL >
```

Figure 106-4

Using Edit (continued)

- At the end of the step, do one of the following. See Figure 107-1.
 - Press **1** to insert a new step. Then, program the new step, selecting the programming condition and commands.
 - or
 - Press **0** to display the next step in the program.
- Repeat steps 4 and 5 of this instruction for each program step.

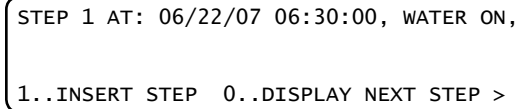

STEP 1 AT: 06/22/07 06:30:00, WATER ON,
1..INSERT STEP 0..DISPLAY NEXT STEP >

Figure 107-1

Using Erase

To erase a Step program from stored in memory, follow the steps below:

- Press **PROGRAM**, **1**, **6** to display the stored programs screen. See Figure 107-2.
- Enter the desired program number from the Stored Programs list at the top of the screen.
- Press **ENTER** to confirm and erase the stored program number. See Figure 107-3.

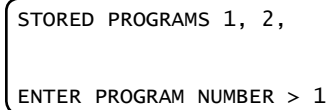

STORED PROGRAMS 1, 2,
ENTER PROGRAM NUMBER > 1

Figure 107-2

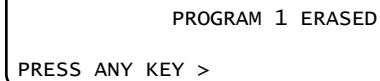

PROGRAM 1 ERASED
PRESS ANY KEY >

Figure 107-3

NOTE: To delete current programs, use the Review Current screen.

Step Programs

Designing Step Programs

A program is a list of conditions and commands which need to occur in a specified order. The completed step program design form example below illustrates how to use the form to outline the following example program. See Figure 109-1.

Example Step Program and Design Form

Current Conditions:

- Machine OFF at 0°.

Program Machine By:

- Time: ON 08/08/07, at 3:00 AM, WATER ON, Depth 1.00", FORWARD, START.
- Position: At 180°, WATER OFF, 100 percent.
- Position: At 225°, WATER ON, Depth 0.75".
- Position: At 0°, STOP.

The program design form has been filled out to reflect the example program. Follow these steps as a guide when thinking about programs you want to write.

1. Make a sketch of the field and identify what you want the irrigation machine to do.
2. Determine what must happen first. This is STEP #1. (Ex. START on 08/08/07 at 3:00 AM).
3. Identify the condition. Will STEP #1 occur at a position in the field, a date/time, a specified time delay or other conditions? (Ex. 08/08/07 at 3:00 AM).
4. Identify what commands need to occur for Step #1. (Ex: WATER ON, 1.00 inch DEPTH, FORWARD, START).
5. Determine conditions and commands for all other steps.

NOTE: All steps are executed in sequential order.

If you complete the step program design form, it makes entering the program easy.

Just follow each column down and enter the correct information.

Blank step program design forms are provided in the Appendix.

Step Program Number 2
Field ID 004

CONDITIONS	STEP NUMBER								
	1	2	3	4	5	6	7	8	9
TIME	08/08/07 3:00 AM								
POSITION		180	225	0					
PRESSURE									
DELAY									
FOR / REV									
OTHER CONDITIONS									
ANALOG									
MODULE									
PULSE									
COUNT									
WIND									
TEMPERATURE									
RAIN									
COMMAND KEYS									
WATER ON	X		X						
WATER OFF		X							
PERCENT		100							
DEPTH	1.00		0.75						
FORWARD									
REVERSE									
STOP-IN-SLOT ON									
STOP-IN-SLOT OFF									
START	X								
STOP				X					
OPTIONS									
AUX 1 ON / OFF									
AUX 2 ON / OFF									
START									
STOP									
CYCLE									
MODULE									
AUTO REVERSE									
AUTO RESTART									

Figure 109-1

Step Program Examples

Example 1. Program by Time and Position

In this program example, the machine is being programmed to start on a specific date and time, water one half of the field, turn the water off, and increase speed over set aside acres. It then turns the water on, sets the depth, and waters the remaining half of the field, stopping at 0°. See Figure 110-1.

Current Machine Condition:

- Machine is OFF at 0°.

Program Machine By:

- Time: ON 08/08/07 at 3:00 AM, WATER ON, FORWARD, Depth 1.00", START.
- Position: At 180°, WATER OFF, Percent 100.
- Position: At 225°, WATER ON, Depth 0.75".
- Position: At 0°, STOP.

Start Programming

To program Example 1, follow these steps.

1. Press **PROGRAM**, **1** for STEP PROGRAMS.
2. Press **2** for CREATE NEW.

Program STEP 1 - Example 1

3. To program the start time, press **1** for TIME.
4. Press **0** for DATE/TIME.
 - a) Enter the date **0**, **8**, **0**, **8**, **0**, **7** for August 8, 2007 and press **ENTER**. See Figure 110-2.
 - b) Enter the time **0**, **3**, **0**, **0**, **0**, **0** for 3:00 AM and press **ENTER**. See Figures 110-3 and 110-4.
5. Enter the commands to execute on 08/08/07 at 3:00 AM. Each command appears on the screen when entered. See Figure 110-5.
 - a) Press **WATER ON**.
 - b) Press **FORWARD**.
 - c) Press **DEPTH**.
 - d) Press **1** for 1.00 inch.
 - e) Press **ENTER** to retain 1.00 inch.
 - f) Press **START**.

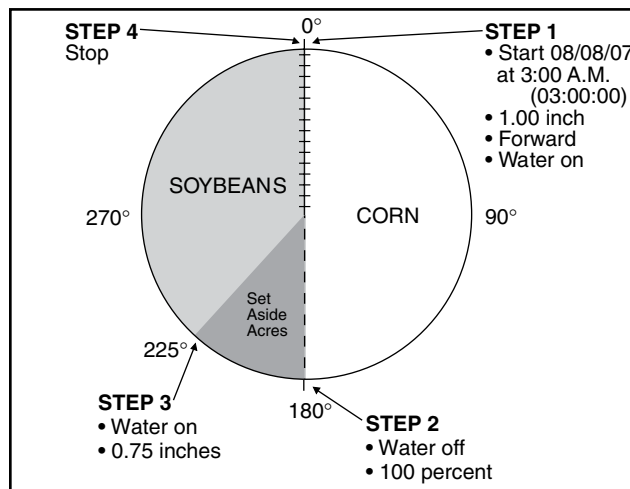

Figure 110-1

```
STEP 1 PROGRAM BY: TIME
ENTER DATE (07/27/07) > 08/08/07
```

Figure 110-2

```
STEP 1 PROGRAM BY: TIME
ENTER TIME (08:04) > 03:00:00
```

Figure 110-3

```
STEP 1 AT: 08/08/07 03:00:00,
ENTER COMMANDS, FINISHED..PRESS ENTER
```

Figure 110-4

```
STEP 1 AT: 08/08/07 03:00:00, WATER ON,
FORWARD, DEPTH 1.00, START,
ENTER COMMANDS, FINISHED..PRESS ENTER
```

Figure 110-5

Example 1. Program by Time and Position (continued)

6. Finish STEP 1 by pressing . See Figure 111-1.



7. Press  for NEXT STEP.

```
0 EXIT
1 PROGRAM FINISHED
2 NEXT STEP
PRESS NUMBER > 2
```

Figure 111-1

Program STEP 2 - Example 1

8. To program the position, press  for POSITION. See Figure 111-2.

a) Press , ,  for 180 degrees.

b) Press  to retain 180 degrees.

```
STEP 2 PROGRAM BY: POSITION



ENTER DEGREES ( 90.0) > 180
```

Figure 111-2

9. Enter the commands to be executed at this position. Each command appears on the screen when entered. See Figure 111-3.

a) Press .

b) Press .

c) Press , ,  for 100 percent.

d) Press  to retain 100 percent.

```
STEP 2 AT: 180.0 DEGREES,

ENTER COMMANDS, FINISHED..PRESS ENTER
```

Figure 111-3

```
STEP 2 AT: 180.0 DEGREES, WATER OFF,
PERCENT 100,

ENTER COMMANDS, FINISHED..PRESS ENTER
```

Figure 111-4

10. Finish STEP 2 by pressing . See Figure 111-4.



11. Press  for NEXT STEP. See Figure 111-5.

```
0 EXIT
1 PROGRAM FINISHED
2 NEXT STEP
PRESS NUMBER > 2
```

Figure 111-5

Program STEP 3 - Example 1

12. To program the next position, press  for POSITION. See Figures 111-6 and 111-7.

a) Press , ,  for 225 degrees.

b) Press  to retain 225 degrees.

```
STEP 3 PROGRAM BY: POSITION

ENTER DEGREES ( 90.0) > 225
```

Figure 111-6

13. Enter the commands to be executed at this position. Each command appears on the screen when entered. See Figure 111-8.

a) Press .

b) Press .

c) Press , ,  for 0.75 inches.

d) Press  to retain 0.75 inches.

```
STEP 3 AT: 225.0 DEGREES,

ENTER COMMANDS, FINISHED..PRESS ENTER
```

Figure 111-7

```
STEP 3 AT: 225.0 DEGREES, WATER ON,
DEPTH 0.75,

ENTER COMMANDS, FINISHED..PRESS ENTER
```

Figure 111-8

Step Program Examples

Example 1. Program by Time and Position (continued)

14. Finish STEP 3 by pressing .
15. Press for NEXT STEP. See Figure 112-1.

Program STEP 4 - Example 1

16. To program the next position, press for POSITION. See Figures 112-2 and 112-3.
- a) Press for 0 degrees.
 - b) Press to retain 0 degrees.
17. Enter the command to be executed at this position by pressing . The command appears on the screen when entered. See Figure 112-4.
18. Finish STEP 4 by pressing .

Finish Programming

19. Finish the program by pressing for PROGRAM FINISHED. See Figure 112-5.
20. Select one of the following. See Figures 112-6, 112-7, and 112-8.
- Press for SAVE PROGRAM.
 - (a) Select program number 1-17.
 - (b) Press to save the program.
 - Press for SAVE PROGRAM AND RUN.
 - (c) Select program number 1-17.
 - (d) Press to save and run the program.
 - Press for CANCEL PROGRAM to cancel the program.
 - Press for RUN THEN DELETE to run the program once and then delete it.

```
0 EXIT
1 PROGRAM FINISHED
2 NEXT STEP
PRESS NUMBER > 2
```

Figure 112-1

```
STEP 4 PROGRAM BY: POSITION

ENTER DEGREES ( 90.0) > 0
```

Figure 112-2

```
STEP 4 AT: 0.0 DEGREES,

ENTER COMMANDS, FINISHED..PRESS ENTER
```

Figure 112-3

```
STEP 4 AT: 0.0 DEGREES, STOP,

ENTER COMMANDS, FINISHED..PRESS ENTER
```

Figure 112-4

```
0 EXIT
1 PROGRAM FINISHED
2 NEXT STEP
PRESS NUMBER > 1
```

Figure 112-5

```
0 EXIT          3 CANCEL PROGRAM
1 SAVE PROGRAM  4 RUN THEN DELETE
2 SAVE PROGRAM AND RUN
PRESS NUMBER > X
```

Figure 112-6

```
STORED PROGRAMS

PRESS NUMBER FROM 1 TO 17 TO SAVE.
ENTER PROGRAM NUMBER > X
```

Figure 112-7

```
PROGRAM X SAVED

PRESS ANY KEY >
```

Figure 112-8

Step Program Examples

Example 2. Program by Day and Time

In this program example, the machine is being programmed to start on specific days and time, water one half of the field, turn the water off, and increase speed over set aside acres. It then turns the water on, sets the depth, and waters the remaining half of the field, stopping at 0°. See Figure 113-1.

Current Machine Condition:

- Machine is OFF at 0°.

Program Machine By:

- Time: ON Mondays, Wednesdays, and Fridays at 3:00 AM, WATER ON, FORWARD, Depth 1.00", START.
- Position: At 180°, WATER OFF, Percent 100.
- Position: At 225°, WATER ON, Depth 0.75".
- Position: At 0°, STOP.

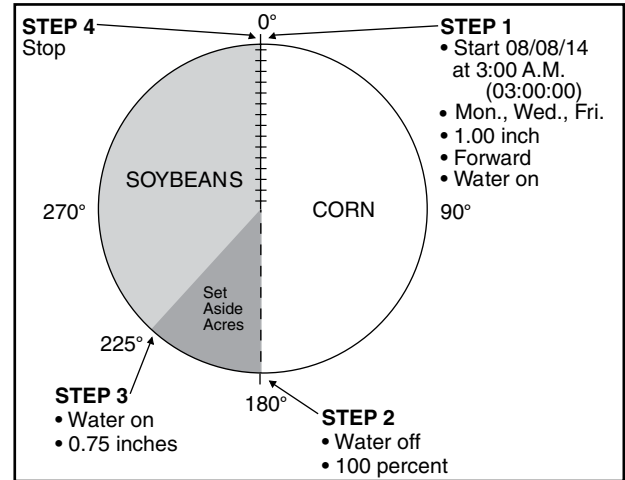

Figure 113-1

Start Programming

To program Example 2, follow these steps.

1. Press **PROGRAM**, **1** for STEP PROGRAMS.
2. Press **2** for CREATE NEW.

Program STEP 1 - Example 2

3. To program the start time, press **1** for TIME.
4. Press **1** for DAY/TIME.
 - a) Enter **2**, **4**, **6** for MONDAY, WEDNESDAY, FRIDAY and press **ENTER**. See Figure 113-2.
 - b) Enter the time **0**, **3**, **0**, **0**, **0**, **0** for 3:00 AM and press **ENTER**. See Figures 113-3 and 113-4.
5. Enter the commands to execute on Mondays, Wednesdays, and Fridays at 3:00 AM. Each command appears on the screen when entered. See Figure 113-5.
 - a) Press **WATER ON**.
 - b) Press **FORWARD**.
 - c) Press **DEPTH**.
 - d) Press **1** for 1.00 inch.
 - e) Press **ENTER** to retain 1.00 inch.
 - f) Press **START**.

```
0 EXIT      3 TUESDAY    6 FRIDAY
1 SUNDAY   4 WEDNESDAY   7 SATURDAY
2 MONDAY   5 THURSDAY
ENTER DAYS (2) > 2,4,6,
```

Figure 113-2

```
STEP 1 PROGRAM BY: TIME

ENTER TIME (06:44) > 03:00:00
```

Figure 113-3

```
STEP 1 AT: MO, WE, FR, 03:00:00,

ENTER COMMANDS, FINISHED..PRESS ENTER
```

Figure 113-4

```
STEP 1 AT: MO, WE, FR, 03:00:00,
WATER ON, FORWARD, DEPTH 1.00, STOP

ENTER COMMANDS, FINISHED..PRESS ENTER
```

Figure 113-5

Step Program Examples



Example 2. Program by Day and Time (continued)

6. Finish STEP 1 by pressing . See Figure 114-1.

7. Press  for NEXT STEP.

Program STEP 2 - Example 2

8. To program the position, press  for POSITION. See Figure 114-2.

a) Press , ,  for 180 degrees.

b) Press  to retain 180 degrees.

9. Enter the commands to be executed at this position. Each command appears on the screen when entered. See Figure 114-3.

a) Press .

b) Press .

c) Press , ,  for 100 percent.



d) Press  to retain 100 percent.

10. Finish STEP 2 by pressing . See Figure 114-4.

11. Press  for NEXT STEP. See Figure 114-5.

Program STEP 3 - Example 2

12. To program the next position, press  for POSITION. See Figures 114-6 and 114-7.



a) Press , ,  for 225 degrees.

b) Press  to retain 225 degrees.

13. Enter the commands to be executed at this position. Each command appears on the screen when entered. See Figure 114-8.

a) Press .

b) Press .

c) Press , ,  for 0.75 inches.

d) Press  to retain 0.75 inches.

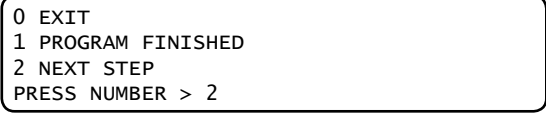

```
0 EXIT
1 PROGRAM FINISHED
2 NEXT STEP
PRESS NUMBER > 2
```

Figure 114-1

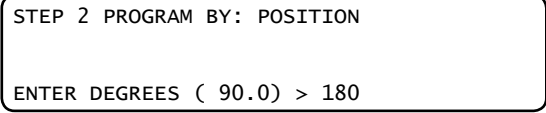

```
STEP 2 PROGRAM BY: POSITION

ENTER DEGREES ( 90.0) > 180
```

Figure 114-2

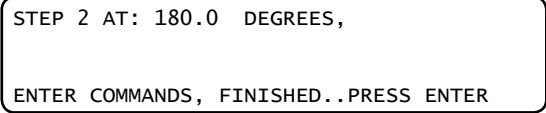

```
STEP 2 AT: 180.0 DEGREES,

ENTER COMMANDS, FINISHED..PRESS ENTER
```

Figure 114-3

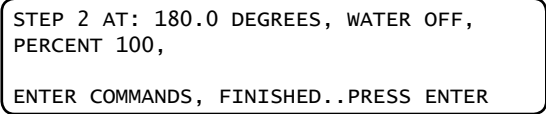

```
STEP 2 AT: 180.0 DEGREES, WATER OFF,
PERCENT 100,

ENTER COMMANDS, FINISHED..PRESS ENTER
```

Figure 114-4



```
0 EXIT
1 PROGRAM FINISHED
2 NEXT STEP
PRESS NUMBER > 2
```

Figure 114-5

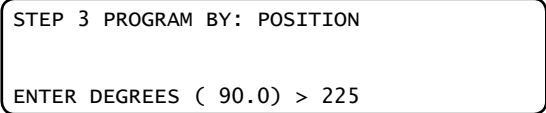

```
STEP 3 PROGRAM BY: POSITION

ENTER DEGREES ( 90.0) > 225
```

Figure 114-6

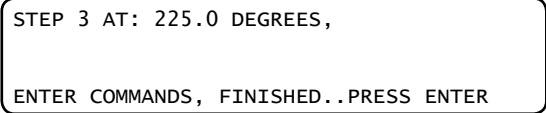

```
STEP 3 AT: 225.0 DEGREES,

ENTER COMMANDS, FINISHED..PRESS ENTER
```

Figure 114-7

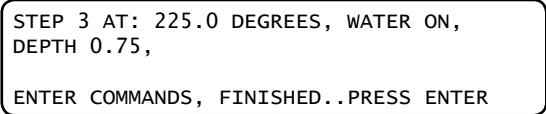

```
STEP 3 AT: 225.0 DEGREES, WATER ON,
DEPTH 0.75,

ENTER COMMANDS, FINISHED..PRESS ENTER
```

Figure 114-8

Example 2. Program by Day and Time (continued)

14. Finish STEP 3 by pressing .
15. Press for NEXT STEP. See Figure 115-1.

Program STEP 4 - Example 2

16. To program the next position, press for POSITION. See Figures 115-2 and 115-3.
 - a) Press for 0 degrees.
 - b) Press to retain 0 degrees.
17. Enter the command to be executed at this position by pressing . The command appears on the screen when entered. See Figure 115-4.
18. Finish STEP 4 by pressing .

Finish Programming

19. Finish the program by pressing for PROGRAM FINISHED. See Figure 115-5.
20. Select one of the following. See Figures 115-6, 115-7, and 115-8.
 - Press for SAVE PROGRAM.
 - (a) Select program number 1-17.
 - (b) Press to save the program.
 - Press for SAVE PROGRAM AND RUN.
 - (c) Select program number 1-17.
 - (d) Press to save and run the program.
 - Press for CANCEL PROGRAM to cancel the program.
 - Press for RUN THEN DELETE to run the program once and then delete it.

```
0 EXIT
1 PROGRAM FINISHED
2 NEXT STEP
PRESS NUMBER > 2
```

Figure 115-1

```
STEP 4 PROGRAM BY: POSITION

ENTER DEGREES ( 90.0) > 0
```

Figure 115-2

```
STEP 4 AT: 0.0 DEGREES,

ENTER COMMANDS, FINISHED..PRESS ENTER
```

Figure 115-3

```
STEP 4 AT: 0.0 DEGREES, STOP,

ENTER COMMANDS, FINISHED..PRESS ENTER
```

Figure 115-4

```
0 EXIT
1 PROGRAM FINISHED
2 NEXT STEP
PRESS NUMBER > 1
```

Figure 115-5

```
0 EXIT          3 CANCEL PROGRAM
1 SAVE PROGRAM  4 RUN THEN DELETE
2 SAVE PROGRAM AND RUN
PRESS NUMBER > X
```

Figure 115-6

```
STORED PROGRAMS

PRESS NUMBER FROM 1 TO 17 TO SAVE.
ENTER PROGRAM NUMBER > X
```

Figure 115-7

```
PROGRAM X SAVED

PRESS ANY KEY >
```

Figure 115-8

Step Program Examples

Example 3. Program by Time and Position with SIS On

In this programming example, the machine is programmed to start at a specific date and time. Water one quarter of the field, turn AUX1 ON and increase speed over one half of the field, then turn AUX1 OFF, slow down and SIS ON to water the remaining quarter of the field. The SIS is set at 90°. See Figure 116-1.

Current Conditions:

- Machine OFF at 90°.
- SIS is ON and set at 90°.

Program Machine By:

- Time: On 08/08/14 at 3:00 AM, Water ON, FORWARD, Depth 0.75", Start.
- Position: At 180°, Aux1 ON, Percent 100.
- Position: At 0°, Aux1 OFF, Depth to 0.75".

Start Programming

To program Example 3, follow these steps.

1. Press **PROGRAM**, **1** for STEP PROGRAMS.
2. Press **2** for CREATE NEW.

Program STEP 1 - Example 3

3. To program the start time, press **1** for TIME.
4. Press **0** for DATE/TIME.
 - a) Enter the date **0**, **8**, **0**, **8**, **1**, **4** for August 8, 2014 and press **ENTER**. See Figure 116-2.
 - b) Enter the time **0**, **3**, **0**, **0**, **0**, **0** for 3:00 AM and press **ENTER**. See Figures 116-3 and 116-4.
5. Enter the commands to execute on 08/08/14 at 3:00 AM. Each command appears on the screen when entered. See Figure 116-5.
 - a) Press **WATER ON**.
 - b) Press **FORWARD**.
 - c) Press **DEPTH**.
 - d) Press **.**, **7**, **5** for 0.75 inch.
 - e) Press **ENTER** to retain 0.75 inch.
 - f) Press **START**.

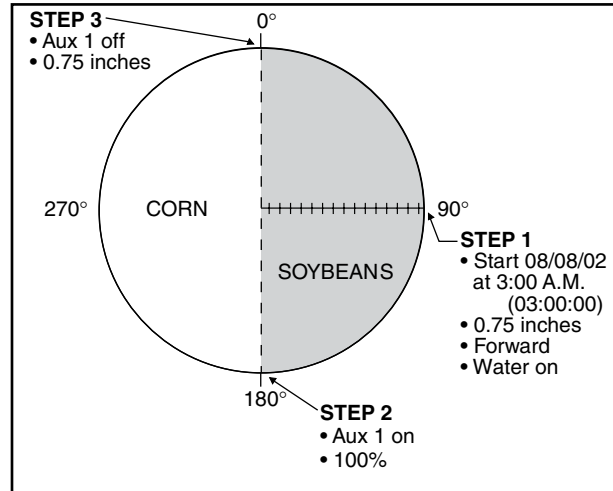

Figure 116-1

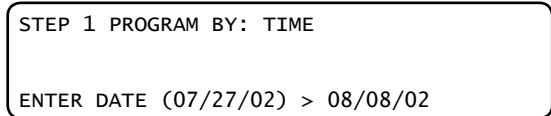

Figure 116-2

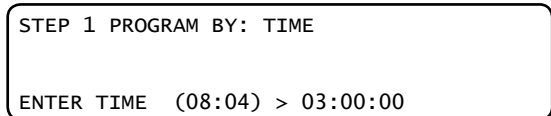

Figure 116-3

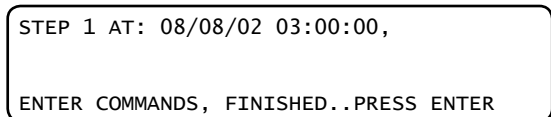

Figure 116-4

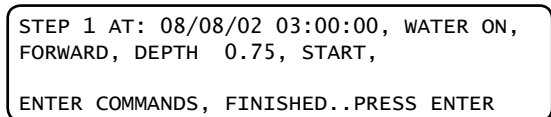

Figure 116-5

Example 3. Program by Time and Position with SIS On (continued)

6. Finish STEP 1 by pressing .
7. Press for NEXT STEP. See Figure 117-1.

Program STEP 2 - Example 3

8. To program the position, press for POSITION. See Figures 117-2 and 117-3.
 - a) Press , , for 180 degrees.
 - b) Press to retain 180 degrees.
9. Enter the commands to be executed at the position. See Figure 117-4.
 - a) Press .
 - b) Press for AUX1.
 - c) Press for AUX1 ON.
 - d) Press .
 - e) Press , , for 100 percent.
 - f) Press to retain 100 percent.
10. Finish STEP 2 by pressing .
11. Press for NEXT STEP. See Figure 117-5.

Program STEP 3 - Example 3

12. To program the next position, press for POSITION. See Figures 117-6 and 117-7.
 - a) Press for 0 degrees.
 - b) Press to retain 0 degrees.

```
0 EXIT
1 PROGRAM FINISHED
2 NEXT STEP
PRESS NUMBER > 2
```

Figure 117-1

```
STEP 2 PROGRAM BY: POSITION

ENTER DEGREES ( 90.0) > 180
```

Figure 117-2

```
STEP 2 AT: 180.0 DEGREES,

ENTER COMMANDS, FINISHED..PRESS ENTER
```

Figure 117-3

```
STEP 2 AT: 180.0 DEGREES, AUXOUT1 ON,
PERCENT 100,

ENTER COMMANDS, FINISHED..PRESS ENTER
```

Figure 117-4

```
0 EXIT
1 PROGRAM FINISHED
2 NEXT STEP
PRESS NUMBER > 2
```

Figure 117-5

```
STEP 3 PROGRAM BY: POSITION

ENTER DEGREES ( 90.0) > 0
```

Figure 117-6

```
STEP 3 AT: 0.0 DEGREES,

ENTER COMMANDS, FINISHED..PRESS ENTER
```

Figure 117-7

Step Program Examples

Example 3. Program by Time and Position with SIS On (continued)

13. Enter the commands to be executed at the position. See Figure 118-1.

- a) Press .
- b) Press for AUX1.
- c) Press for AUX1 OFF.
- d) Press .
- e) Press , , for 0.75 inch.
- f) Press to retain 0.75 inches.

14. Finish STEP 3 by pressing .

```
STEP 3 AT: 225.0 DEGREES, AUXOUT1 OFF,  
DEPTH 0.75,  
  
ENTER COMMANDS, FINISHED..PRESS ENTER
```

Figure 118-1

Finish Programming

15. Finish the program by pressing for PROGRAM FINISHED. See Figure 118-2.

16. Select one of the following. See Figures 118-3, 118-4, and 118-5.

- Press for SAVE PROGRAM.
 - a) Select program number 1-17.
 - b) Press to save the program.
- Press for SAVE PROGRAM AND RUN.
 - c) Select program number 1-17.
 - d) Press to save and run the program.
- Press for CANCEL PROGRAM to cancel the program.
- Press for RUN THEN DELETE to run the program once and then delete it.

```
0 EXIT  
1 PROGRAM FINISHED  
2 NEXT STEP  
PRESS NUMBER > 1
```

Figure 118-2

```
0 EXIT          3 CANCEL PROGRAM  
1 SAVE PROGRAM 4 RUN THEN DELETE  
2 SAVE PROGRAM AND RUN  
PRESS NUMBER > X
```

Figure 118-3

```
STORED PROGRAMS  
  
PRESS NUMBER FROM 1 TO 17 TO SAVE.  
ENTER PROGRAM NUMBER > X
```

Figure 118-4

```
PROGRAM X SAVED  
  
PRESS ANY KEY >
```

Figure 118-5

Example 4. Program by Position and Delay

In this example, the machine is being programmed to REVERSE at 270° and STOP at 90°. End-of-field stop/ auto reverse is not being used since there are no physical obstacles in the field. See Figure 119-1.

Current Conditions:

- Machine RUNNING at 90°; FORWARD; 50 percent; WATER ON.

Program Machine By:

- Position: At 180°, Percent 80.
- Position: At 270°, REVERSE, Percent 0.
- Delay: After 600 seconds (10 minutes), Percent 50. (600 second delay to improve water uniformity at reverse point).
- Position: At 180°, Percent 80.
- Position: At 90°, Percent 0
- Delay: After 600 seconds, STOP. (600 second delay to improve water uniformity at stopping point).

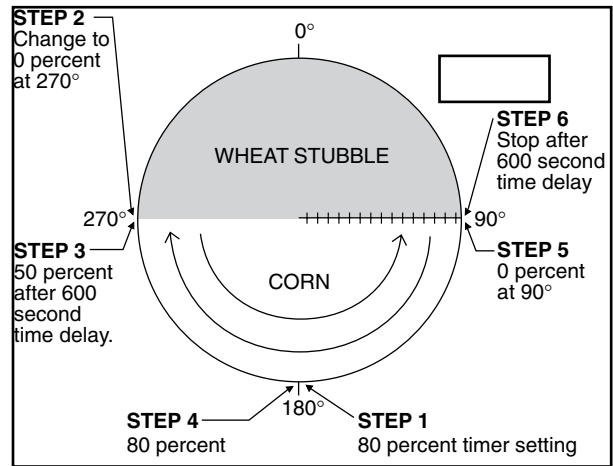

Figure 119-1

Start Programming

To program Example 4, follow these steps.

1. Press **PROGRAM**, **1** for STEP PROGRAMS.
2. Press **2** for CREATE NEW.

Program STEP 1 - Example 4

3. To program the position, press **2** for POSITION. See Figures 119-2 and 119-3.
 - a) Press **1**, **8**, **0** for 180 degrees.
 - b) Press **ENTER** to retain 180 degrees.
4. Enter the command to be executed at this position. See Figure 119-4.
 - a) Press **PERCENT**.
 - b) Press **8**, **0** for 80 percent.
 - c) Press **ENTER** to retain 80 percent.
5. Finish STEP 1 by pressing **ENTER**.
6. Press **2** for NEXT STEP. See Figure 119-5.

```
STEP 1 PROGRAM BY: POSITION
ENTER DEGREES ( 90.0) > 180
```

Figure 119-2

```
STEP 1 AT: 180.0 DEGREES,
ENTER COMMANDS, FINISHED..PRESS ENTER
```

Figure 119-3

```
STEP 1 AT: 180.0 DEGREES, PERCENT 80,
ENTER COMMANDS, FINISHED..PRESS ENTER
```

Figure 119-4

```
0 EXIT
1 PROGRAM FINISHED
2 NEXT STEP
PRESS NUMBER > 2
```

Figure 119-5

Step Program Examples

Example 4. Program by Position and Delay (continued)

7. To program the next position, press **2** for POSITION. See Figures 120-1 and 120-2.
 - a) Press **2**, **7**, **0** for 270 degrees.
 - b) Press **ENTER** to retain 270 degrees.
8. Enter the commands to be executed at this position. See Figure 120-3.
 - a) Press **REVERSE**.
 - b) Press **PERCENT**.
 - c) Press **0** for 0 percent.
 - d) Press **ENTER** to retain 0 percent.
9. Finish STEP 2 by pressing **ENTER**.
10. Press **2** for NEXT STEP. See Figure 120-4.

Program STEP 3 - Example 4

11. To program the delay time, press **4** for DELAY. See Figures 120-5, 120-6, and 120-7.
 - a) Press **0** for SECONDS.
 - b) Press **6**, **0**, **0** for 600 seconds.
 - c) Press **ENTER** to retain 600 seconds.

NOTE: A delay only counts as down time when the power is ON.
12. Enter the command to be executed at the delay. See Figure 120-8.
 - a) Press **PERCENT**.
 - b) Press **5**, **0** for 50 percent.
 - c) Press **ENTER** to retain 50 percent.
13. Finish STEP 3 by pressing **ENTER**.
14. Press **2** for NEXT STEP. See Figure 120-9

```
STEP 2 PROGRAM BY: POSITION  
  
ENTER DEGREES ( 90.0) > 270
```

Figure 120-1

```
STEP 2 AT: 270.0 DEGREES,  
  
ENTER COMMANDS, FINISHED..PRESS ENTER
```

Figure 120-2

```
STEP 2 AT: 270.0 DEGREES, REVERSE,  
PERCENT 0,  
  
ENTER COMMANDS, FINISHED..PRESS ENTER
```

Figure 120-3

```
0 EXIT  
1 PROGRAM FINISHED  
2 NEXT STEP  
PRESS NUMBER > 2
```

Figure 120-4

```
STEP 3 PROGRAM BY: DELAY  
  
DELAY 0..SECONDS 1..MINUTES > 0
```

Figure 120-5

```
STEP 3 PROGRAM BY: DELAY  
  
ENTER DELAY IN SECONDS > 600
```

Figure 120-6

```
STEP 3 AT: 600 SECONDS DELAY,  
  
ENTER COMMANDS, FINISHED..PRESS ENTER
```

Figure 120-7

```
STEP 3 AT: 600 SECONDS DELAY,  
PERCENT 50,  
  
ENTER COMMANDS, FINISHED..PRESS ENTER
```

Figure 120-8

```
0 EXIT  
1 PROGRAM FINISHED  
2 NEXT STEP  
PRESS NUMBER > 2
```

Figure 120-9

Example 4. Program by Position and Delay (continued)

Program STEP 4 - Example 4

15. To program the next position, press for POSITION.
See Figures 121-1 and 121-2.

a) Press , , for 180 degrees.

b) Press to retain 180 degrees.

16. Enter the commands to be executed at this position. See Figure 121-3.

a) Press .

b) Press , for 80 percent.

c) Press to retain 80 percent.

17. Finish STEP 4 by pressing .

18. Press for NEXT STEP. See Figure 121-4.

Program STEP 5 - Example 4

19. To program the next position, press for POSITION.
See Figures 121-5 and 121-6.

a) Press , for 90 degrees.

b) Press to retain 90 degrees.

20. Enter the commands to be executed at the position. See Figure 121-7.

a) Press .

b) Press for 0 percent.

c) Press to retain 0 percent.

21. Finish STEP 5 by pressing .

22. Press for NEXT STEP. See Figure 121-8.

```
STEP 4 PROGRAM BY: POSITION
```

```
ENTER DEGREES ( 90.0 ) > 180
```

Figure 121-1

```
STEP 4 AT: 180.0 DEGREES,
```

```
ENTER COMMANDS, FINISHED..PRESS ENTER
```

Figure 121-2

```
STEP 4 AT: 180.0 DEGREES, PERCENT 80,
```

```
ENTER COMMANDS, FINISHED..PRESS ENTER
```

Figure 121-3

```
0 EXIT  
1 PROGRAM FINISHED  
2 NEXT STEP  
PRESS NUMBER > 2
```

Figure 121-4

```
STEP 5 PROGRAM BY: POSITION
```

```
ENTER DEGREES ( 180.0 ) > 90
```

Figure 121-5

```
STEP 5 AT: 90.0 DEGREES,
```

```
ENTER COMMANDS, FINISHED..PRESS ENTER
```

Figure 121-6

```
STEP 5 AT: 90.0 DEGREES, PERCENT 0,
```

```
ENTER COMMANDS, FINISHED..PRESS ENTER
```

Figure 121-7

```
0 EXIT  
1 PROGRAM FINISHED  
2 NEXT STEP  
PRESS NUMBER > 2
```

Figure 121-8

Step Program Examples

Example 4. Program by Position and Delay (continued)

Program STEP 6 - Example 3

23. To program the delay time, press for DELAY. See Figures 122-1, 122-2, and 122-3.

- a) Press for SECONDS.
- b) Press , , for 600 seconds.
- c) Press to retain 600 seconds.

NOTE: A delay only counts as down time when the power is ON.

24. Enter the command to be executed at the delay by pressing . See Figure 122-4.

25. Finish STEP 6 by pressing .

Finish Programming

26. Finish the program by pressing for PROGRAM FINISHED. See Figure 122-5.

27. Select one of the following. See Figures 122-6, 122-7, and 122-8.

- Press for SAVE PROGRAM.
 - (a) Select program number 1-17.
 - (b) Press to save the program.
- Press for SAVE PROGRAM AND RUN.
 - (c) Select program number 1-17.
 - (d) Press to save and run the program.
- Press for CANCEL PROGRAM to cancel the program.
- Press for RUN THEN DELETE to run the program once and then delete it.

```
STEP 6 PROGRAM BY: DELAY
DELAY 0..SECONDS 1..MINUTES > 0
```

Figure 122-1

```
STEP 6 PROGRAM BY: DELAY
ENTER DELAY IN SECONDS > 600
```

Figure 122-2

```
STEP 6 AT: 600 SECONDS DELAY,
ENTER COMMANDS, FINISHED..PRESS ENTER
```

Figure 122-3

```
STEP 6 AT: 600 SECONDS DELAY, STOP,
ENTER COMMANDS, FINISHED..PRESS ENTER
```

Figure 122-4

```
0 EXIT
1 PROGRAM FINISHED
2 NEXT STEP
PRESS NUMBER >
```

Figure 122-5

```
0 EXIT          3 CANCEL PROGRAM
1 SAVE PROGRAM  4 RUN THEN DELETE
2 SAVE PROGRAM AND RUN
PRESS NUMBER >
```

Figure 122-6

```
STORED PROGRAMS
PRESS NUMBER FROM 1 TO 17 TO SAVE.
ENTER PROGRAM NUMBER > X
```

Figure 122-7

```
PROGRAM X SAVED
PRESS ANY KEY >
```

Figure 122-8

Step Program Examples

Example 5. Program by Position, Delay, and Direction

In this example, the Percent Timer is programmed to 0 when the end-of-field stop/auto reverse actuator arms are tripped at 270° and 90°. Allowing the end-of-field stop/auto-reverse hardware to reverse the machine provides more accuracy than programming a position to reverse the machine. See Figure 123-1.

Current Conditions:

- Machine RUNNING at 90°, FORWARD, 50 percent, WATER ON.
- The machine is equipped with end-of-field stop/auto reverse hardware. Barriers are located at 90° and 270° to trip the arms and change machine direction.
- AR/AS delay is set to 0.

Program Machine By:

- Position: At 180°, Percent 80.
- Position: At 270°, Percent 0, REVERSE.
- Delay: After 600 seconds (10 minutes), Percent 50. (600 second delay to improve water uniformity at reverse point).
- Position: At 180°, Percent 80. (machine is traveling in the REVERSE direction).
- Position: At 0°, Percent 0, FORWARD.
- Delay: After 600 seconds, STOP. (600 second delay to improve water uniformity at stopping point)

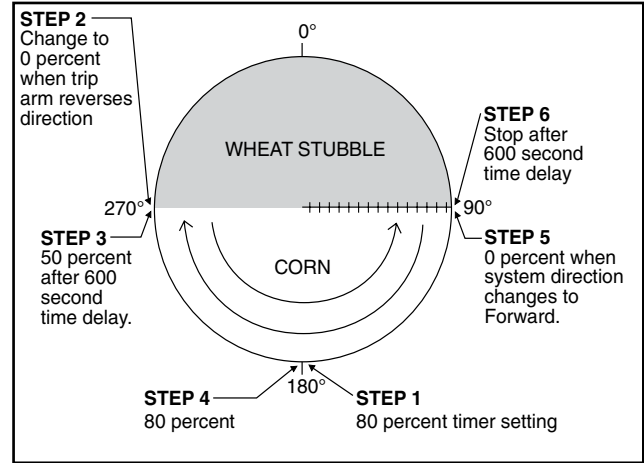

Figure 123-1

Start Programming

To program Example 5, follow these steps.

1. Press **PROGRAM**, **1** for STEP PROGRAMS.
2. Press **2** for CREATE NEW.

Program STEP 1 - Example 5

3. To program the position, press **2** for POSITION. See Figures 123-2 and 123-3.
 - a) Press **1**, **8**, **0** for 180 degrees.
 - b) Press **ENTER** to retain 180 degrees.
4. Enter the command to be executed at this position. See Figure 123-4.
 - a) Press **PERCENT**.
 - b) Press **8**, **0** for 80 percent.
 - c) Press **ENTER** to retain 80 percent.

```
STEP 1 PROGRAM BY: POSITION
ENTER DEGREES ( 90.0) > 180
```

Figure 123-2

```
STEP 1 AT: 180.0 DEGREES,
ENTER COMMANDS, FINISHED..PRESS ENTER
```

Figure 123-3

```
STEP 1 AT: 180.0 DEGREES, PERCENT 80,
ENTER COMMANDS, FINISHED..PRESS ENTER
```

Figure 123-4

Step Program Examples

Example 5. Program by Position, Delay, and Direction (continued)

5. Finish STEP 1 by pressing .
6. Press for NEXT STEP. See Figure 124-1.

Program STEP 2 - Example 5

7. To program the direction, press for FOR/REV. See Figures 124-2 and 124-3.
 - a) Press for FOR/REV.
 - b) Press for REVERSE.
8. Enter the commands to be executed when the machine changes direction from FORWARD to REVERSE. See Figure 124-4.
 - a) Press .
 - b) Press for 0 percent.
 - c) Press to retain 0 percent.
9. Finish STEP 2 by pressing .
10. Press for NEXT STEP. See Figure 124-5.

Program STEP 3 - Example 5

11. To program the delay time, press for DELAY. See Figures 124-6, 124-7, and 124-8.
 - a) Press for MINUTES.
 - b) Press , for 10 minutes.
 - c) Press to retain 10 minutes.
12. Enter the command to be executed at the delay. See Figure 124-9.
 - a) Press .
 - b) Press , for 50 percent.
 - c) Press to retain 50 percent.

```
0 EXIT
1 PROGRAM FINISHED
2 NEXT STEP
PRESS NUMBER > 2
```

Figure 124-1

```
STEP 2 PROGRAM BY: DIRECTION

DIRECTION 0..FORWARD 1..REVERSE > 1
```

Figure 124-2

```
STEP 2 AT: REVERSE,

ENTER COMMANDS, FINISHED..PRESS ENTER
```

Figure 124-3

```
STEP 2 AT: REVERSE, PERCENT 0,

ENTER COMMANDS, FINISHED..PRESS ENTER
```

Figure 124-4

```
0 EXIT
1 PROGRAM FINISHED
2 NEXT STEP
PRESS NUMBER >
```

Figure 124-5

```
STEP 3 PROGRAM BY: DELAY

DELAY 0..SECONDS 1..MINUTES >
```

Figure 124-6

```
STEP 3 PROGRAM BY: DELAY

ENTER DELAY IN MINUTES > 10
```

Figure 124-7

```
STEP 3 AT: 10 MINUTES DELAY,

ENTER COMMANDS, FINISHED..PRESS ENTER
```

Figure 124-8

```
STEP 3 AT: 10 MINUTES DELAY,
PERCENT 50,

ENTER COMMANDS, FINISHED..PRESS ENTER
```

Figure 124-9

Example 5. Program by Position, Delay, and Direction (continued)

13. Finish STEP 3 by pressing .

14. Press for NEXT STEP. See Figure 125-1.

```
0 EXIT
1 PROGRAM FINISHED
2 NEXT STEP
PRESS NUMBER > 2
```

Figure 125-1

Program STEP 4 - Example 5

15. To program the next position, press for POSITION. See Figures 125-2 and 125-3.

a) Press , , for 180 degrees.

b) Press to retain 180 degrees.

```
STEP 4 PROGRAM BY: POSITION

ENTER DEGREES ( 90.0) > 180
```

Figure 125-2

16. Enter the command to be executed at this position. See Figure 125-4.

a) Press .

b) Press , for 80 percent.

c) Press to retain 80 percent.

```
STEP 4 AT: 180.0 DEGREES,

ENTER COMMANDS, FINISHED..PRESS ENTER
```

Figure 125-3

17. Finish STEP 4 by pressing .

18. Press for NEXT STEP. See Figure 125-5.

```
STEP 4 AT: 180.0 DEGREES, PERCENT 80,

ENTER COMMANDS, FINISHED..PRESS ENTER
```

Figure 125-4

Program STEP 5 - Example 5

19. To program the direction press for FOR/REV. See Figures 125-6 and 125-7.

20. Press for FORWARD.

21. Enter the commands to be executed when the machine changes direction from REVERSE to FORWARD. See Figure 125-8.

a) Press .

b) Press for 0 percent.

c) Press to retain 0 percent.

```
0 EXIT
1 PROGRAM FINISHED
2 NEXT STEP
PRESS NUMBER >
```

Figure 125-5

```
STEP 5 PROGRAM BY: DIRECTION

DIRECTION 0..FORWARD 1..REVERSE > 0
```

Figure 125-6

```
STEP 5 AT: FORWARD,

ENTER COMMANDS, FINISHED..PRESS ENTER
```

Figure 125-7

```
STEP 5 AT: FORWARD, PERCENT 0,

ENTER COMMANDS, FINISHED..PRESS ENTER
```

Figure 125-8

Step Program Examples

Example 5. Program by Position, Delay, and Direction (continued)

22. Finish STEP 5 by pressing .

23. Press for NEXT STEP. See Figure 126-1.

Program STEP 6 - Example 5

24. To program the delay time, press for DELAY. See Figures 126-2, 126-3, and 126-4.

a) Press for MINUTES.

b) Press , for 10 minutes.

c) Press to retain 10 minutes.

25. Press as the command to be executed at the delay. See Figure 126-5.

26. Finish STEP 6 by pressing .

Finish Programming

27. Finish the program by pressing for PROGRAM FINISHED. See Figure 126-6.

28. Select one of the following. See Figures 126-7, 126-8, and 126-9.

- Press for SAVE PROGRAM.
 - (a) Select program number 1-17.
 - (b) Press to save the program.
- Press for SAVE PROGRAM AND RUN.
 - (c) Select program number 1-17.
 - (d) Press to save and run the program.
- Press for CANCEL PROGRAM to cancel the program.
- Press for RUN THEN DELETE to run the program once and then delete it.

```
0 EXIT
1 PROGRAM FINISHED
2 NEXT STEP
PRESS NUMBER > 2
```

Figure 126-1

```
STEP 6 PROGRAM BY: DELAY
```

```
DELAY 0..SECONDS 1..MINUTES > 1
```

Figure 126-2

```
STEP 6 PROGRAM BY: DELAY
```

```
ENTER DELAY IN MINUTES > 10
```

Figure 126-3

```
STEP 6 AT: 10 MINUTES DELAY,
```

```
ENTER COMMANDS, FINISHED..PRESS ENTER
```

Figure 126-4

```
STEP 6 AT: 10 MINUTES DELAY, STOP,
```

```
ENTER COMMANDS, FINISHED..PRESS ENTER
```

Figure 126-5

```
0 EXIT
1 PROGRAM FINISHED
2 NEXT STEP
PRESS NUMBER > 1
```

Figure 126-6

```
0 EXIT          3 CANCEL PROGRAM
1 SAVE PROGRAM  4 RUN THEN DELETE
2 SAVE PROGRAM AND RUN
PRESS NUMBER >
```

Figure 126-7

```
STORED PROGRAMS
```

```
PRESS NUMBER FROM 1 TO 17 TO SAVE.
ENTER PROGRAM NUMBER >
```

Figure 126-8

```
PROGRAM X SAVED
```

```
PRESS ANY KEY >
```

Figure 126-9

Example 6. Program by Pressure

In this example, the machine is programmed by pressure to compensate for reduced flow rate/low pressure due to draw-down of the well. The program must be loaded with the pressure reading on the screen greater than 25 psi, otherwise the program executes immediately as soon as it is run. The program runs only one time. If the pressure returns to 33 psi, the machine still continues to run at 44 percent. A second program can be created that looks for a pressure higher than 30 psi and sets the machine back to 50 percent.

Several variables are involved when trying to determine an adjustment to machine speed based on the operating pressure. Several of these include field elevations and the use of pressure regulators. Valmont Irrigation is not responsible for a degradation of water uniformity caused by adjusting the speed of the machine based on pressure readings at the pivot. Contact your local Valley dealer for further information regarding this subject.

Current Conditions:

- Machine is operating at 33 psi water pressure.
- After 4-5 hours, the draw-down of the well increases, causing the pressure to drop approximately 8 psi.

Program Machine By:

- Pressure: when the pressure drops below 25 psi, set the percent to 44. This may help compensate for the reduced flow rate due to a drop in pressure.

Start Programming

To program Example 6, follow these steps.

1. Press **PROGRAM**, **1** for STEP PROGRAMS.
2. Press **2** for CREATE NEW.

Program STEP 1 - Example 6

3. To program by pressure, Press **3** for PRESSURE. See Figures 127-1, 127-2, and 127-3.
 - a) Press **2**, **5** for 25 psi.
 - b) Press **ENTER** to retain 25 psi.
 - c) Press **0** for LOWER.
4. Enter the command to be executed when the water pressure drops below 25 psi. See Figure 127-4.
 - a) Press **PERCENT**.
 - b) Press **4**, **4** for 44 percent.
 - c) Press **ENTER** to retain 44 percent.
5. Finish STEP 6 by pressing **ENTER**.

```
STEP 1 PROGRAM BY: PRESSURE
ENTER PRESSURE ( 00) > 25
```

Figure 127-1

```
STEP 1 PROGRAM BY: PRESSURE
1..HIGHER 0..LOWER > 0
```

Figure 127-2

```
STEP 1 AT: PRESSURE LESS THAN 25,
ENTER COMMANDS, FINISHED..PRESS ENTER
```

Figure 127-3

```
STEP 1 AT: PRESSURE LESS THAN 25,
PERCENT 44,
ENTER COMMANDS, FINISHED..PRESS ENTER
```

Figure 127-4

Step Program Examples

Example 6. Program by Pressure (continued)

Finish Programming

6. Finish the program by pressing for PROGRAM FINISHED. See Figure 128-1.
7. Select one of the following. See Figures 128-2, 128-3, and 128-4.
 - Press for SAVE PROGRAM.
 - (a) Select program number 1-17.
 - (b) Press to save the program.
 - Press for SAVE PROGRAM AND RUN.
 - (c) Select program number 1-17.
 - (d) Press to save and run the program.
 - Press for CANCEL PROGRAM to cancel the program.
 - Press for RUN THEN DELETE to run the program once and then delete it.

```
0 EXIT
1 PROGRAM FINISHED
2 NEXT STEP
PRESS NUMBER > 1
```

Figure 128-1

```
0 EXIT          3 CANCEL PROGRAM
1 SAVE PROGRAM  4 RUN THEN DELETE
2 SAVE PROGRAM AND RUN
PRESS NUMBER >
```

Figure 128-2

```
STORED PROGRAMS

PRESS NUMBER FROM 1 TO 17 TO SAVE.
ENTER PROGRAM NUMBER >
```

Figure 128-3

```
PROGRAM X SAVED

PRESS ANY KEY >
```

Figure 128-4

Example 7. Program by Position, Delay, and Module

Module is another name for a relay. The machine is controlled by a series of relays located in the control panel. Each relay is either closed (ON) or open (OFF) as the machine is operating. The machine can be programmed to perform commands based on the condition of any one of these relays. See Figure 129-1.

Following is a list of the modules:

0 Safety Out	13 Low Side 1
1 Percent Timer	14 Low Side 2
2 End Gun	15 Not Used
3 Wide Boundary	16 Remote Start
4 Pump Safety	17 Pressure Switch
5 Alarm	18 3 Second timer
6 Auxiliary 1 Output	19 Auxiliary 2 Input
7 Auxiliary 2 Output	20 Auxiliary 1 Input
8 Contactor Enable	21 Reverse Sense
9 Direction (Fwd=ON, Rev=OFF)	22 Forward Sense
10 Control Panel Backlight	23 Safety Sense
11 TTL Output 2	24 PC4
12 TTL Output 1	25 PC5

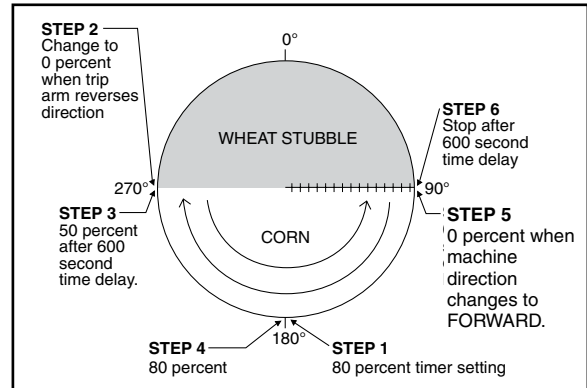

Figure 129-1

Modules #21 Reverse Sense and #22 Forward Sense are used to demonstrate how to program by module instead of forward/reverse.

Current Conditions:

- Machine RUNNING at 90°, FORWARD, 50 percent, WATER ON
- The machine is equipped with end-of-field stop/autoreverse hardware. Barriers are located at 90° and 270° to trip the arms and change machine direction.

Program Machine By:

- Position: At 180°, Percent 80.
- Position: At 270°, Percent 0 (the arm trips and reverses the machine).
- Delay: At 600 seconds, Percent 50 (10 minute delay to improve water uniformity at reverse point).
- Position: At 180°, Percent 80 (machine is travelling in the REVERSE direction).
- Position: At 90°, Percent 0.
- Delay: At 600 seconds, STOP.

Start Programming

To program Example 7, follow these steps.

1. Press **PROGRAM**, **1** for STEP PROGRAMS.
2. Press **2** for CREATE NEW.

Program STEP 1 - Example 7

1. To program the position, press **2** for POSITION. See Figures 129-2 and 129-3.
 - a) Press **1**, **8**, **0** for 180 degrees.
 - b) Press **ENTER** to retain 180 degrees.
2. Enter the command to be executed at this position. See Figure 129-4.
 - a) Press **PERCENT**.
 - b) Press **8**, **0** for 80 percent.
 - c) Press **ENTER** to retain 80 percent.

```
STEP 1 PROGRAM BY: POSITION
ENTER DEGREES ( 90.0 ) > 180
```

Figure 129-2

```
STEP 1 AT: 180.0 DEGREES,
ENTER COMMANDS, FINISHED..PRESS ENTER
```

Figure 129-3

```
STEP 1 AT: 180.0 DEGREES, PERCENT 80,
ENTER COMMANDS, FINISHED..PRESS ENTER
```

Figure 129-4

Step Program Examples

Example 7. Program by Position, Delay, and Module (continued)

3. Finish STEP 1 by pressing .
4. Press for NEXT STEP. See Figure 130-1.

Program STEP 2 - Example 7

5. To program by module, press for OTHER and for MODULE. See Figures 130-2, 130-3, and 130-4.
 - a) Press , for MODULE NUMBER (21 - Reverse Sense).
 - b) Press to retain module number.
 - c) Press for MODULE 21 ON.
6. Enter the commands to be executed when the machine contacts the barrier and changes direction from FORWARD to REVERSE and module 21 is ON. See Figure 130-5.
 - a) Press .
 - b) Press for 0 percent.
 - c) Press to retain 0 percent.
7. Finish STEP 2 by pressing .
8. Press for NEXT STEP. See Figure 130-6.

Program STEP 3 - Example 7

9. To program the delay time, press for DELAY. See Figures 130-7, 130-8, and 130-9.
 - a) Press for MINUTES.
 - b) Press , for 10 minutes.
 - c) Press to retain 10 minutes.

```
0 EXIT
1 PROGRAM FINISHED
2 NEXT STEP
PRESS NUMBER > 2
```

Figure 130-1

```
STEP 2 PROGRAM BY: MODULE

ENTER MODULE NUMBER > 21
```

Figure 130-2

```
STEP 2 PROGRAM BY: MODULE

MODULE 21 1..ON 0..OFF (OFF) >
```

Figure 130-3

```
STEP 2 AT: MODULE 21 ON,

ENTER COMMANDS, FINISHED..PRESS ENTER
```

Figure 130-4

```
STEP 2 AT: MODULE 21 ON, PERCENT 0,

ENTER COMMANDS, FINISHED..PRESS ENTER
```

Figure 130-5

```
0 EXIT
1 PROGRAM FINISHED
2 NEXT STEP
PRESS NUMBER > 2
```

Figure 130-6

```
STEP 3 PROGRAM BY: DELAY

DELAY 0..SECONDS 1..MINUTES > 1
```

Figure 130-7

```
STEP 3 PROGRAM BY: DELAY

ENTER DELAY IN MINUTES > 10
```

Figure 130-8

```
STEP 3 AT: 10 MINUTES DELAY,

ENTER COMMANDS, FINISHED..PRESS ENTER
```

Figure 130-9

Example 7. Program by Position, Delay, and Module (continued)

10. Enter the command to be executed at this position. See Figure 131-1.

- a) Press .
- b) Press , for 50 percent.
- c) Press to retain 50 percent.

11. Finish STEP 3 by pressing .

12. Press for NEXT STEP. See Figure 131-2.

```
STEP 3 AT: 10 MINUTES DELAY,  
PERCENT 50,  
  
ENTER COMMANDS, FINISHED..PRESS ENTER
```

Figure 131-1

```
0 EXIT  
1 PROGRAM FINISHED  
2 NEXT STEP  
PRESS NUMBER > 2
```

Figure 131-2

Program STEP 4 - Example 7

13. To program the next position, press for POSITION. See Figures 131-3 and 131-4.

- a) Press , , for 180 degrees.
- b) Press to retain 180 degrees.

14. Enter the commands to be executed at this position. See Figure 131-5.

- a) Press .
- b) Press , for 80 percent.
- c) Press to retain 80 percent.

15. Finish STEP 4 by pressing .

16. Press for NEXT STEP. See Figure 131-6.

```
STEP 4 PROGRAM BY: POSITION  
  
ENTER DEGREES ( 90.0) > 180
```

Figure 131-3

```
STEP 4 AT: 180.0 DEGREES,  
  
ENTER COMMANDS, FINISHED..PRESS ENTER
```

Figure 131-4

```
STEP 4 AT: 180.0 DEGREES, PERCENT 80,  
  
ENTER COMMANDS, FINISHED..PRESS ENTER
```

Figure 131-5

```
0 EXIT  
1 PROGRAM FINISHED  
2 NEXT STEP  
PRESS NUMBER > 2
```

Figure 131-6

Step Program Examples

Example 7. Program by Position, Delay, and Module (continued)

Program STEP 5 - Example 7

17. To program by module, press **6** for OTHER and **2** for MODULE. See Figures 132-1, 132-2, and 132-3.

- a) Press **2**, **2** for MODULE NUMBER (22 - Forward Sense).
- b) Press **ENTER** to retain module number.
- c) Press **1** for MODULE 22 ON.

18. Enter the commands to be executed when the machine contacts the barrier and changes direction from REVERSE to FORWARD. See Figure 132-4.

- a) Press **PERCENT**.
- b) Press **0** for 0 percent.
- c) Press **ENTER** to retain 0 percent.

19. Finish STEP 5 by pressing **ENTER**.

20. Press **2** for NEXT STEP. See Figure 132-5.

Program STEP 6 - Example 7

21. To program the delay time, press **4** for DELAY. See Figures 132-6, 132-7, and 132-8.

- a) Press **1** for MINUTES.
- b) Press **1**, **0** for 10 minutes.
- c) Press **ENTER** to retain 10 minutes.

STEP 5 PROGRAM BY: MODULE

ENTER MODULE NUMBER > 22

Figure 132-1

STEP 5 PROGRAM BY: MODULE

MODULE 22 1..ON 0..OFF (OFF) > 1

Figure 132-2

STEP 5 AT: MODULE 22 ON,

ENTER COMMANDS, FINISHED..PRESS ENTER

Figure 132-3

STEP 5 AT: MODULE 22 ON, PERCENT 0,

ENTER COMMANDS, FINISHED..PRESS ENTER

Figure 132-4

0 EXIT
1 PROGRAM FINISHED
2 NEXT STEP
PRESS NUMBER > 2

Figure 132-5

STEP 6 PROGRAM BY: DELAY

DELAY 0..SECONDS 1..MINUTES > 1

Figure 132-6

STEP 6 PROGRAM BY: DELAY

ENTER DELAY IN MINUTES > 10

Figure 132-7

STEP 6 AT: 10 MINUTES DELAY,

ENTER COMMANDS, FINISHED..PRESS ENTER

Figure 132-8

Example 7. Program by Position, Delay and Module (continued)

22. Enter the command to be executed at this position. See Figure 133-1.

a) Press .

23. Finish STEP 6 by pressing .

```
STEP 6 AT: 10 MINUTES DELAY, STOP,  
ENTER COMMANDS, FINISHED..PRESS ENTER
```

Figure 133-1

Finish Programming

24. Finish the program by pressing for PROGRAM FINISHED. See Figure 133-2.

25. Select one of the following. See Figures 133-3, 133-4, and 133-5.

- Press for SAVE PROGRAM.
 - (a) Select program number 1-17.
 - (b) Press to save the program.
- Press for SAVE PROGRAM AND RUN.
 - (c) Select program number 1-17.
 - (d) Press to save and run the program.
- Press for CANCEL PROGRAM to cancel the program.
- Press for RUN THEN DELETE to run the program once and then delete it.

```
0 EXIT  
1 PROGRAM FINISHED  
2 NEXT STEP  
PRESS NUMBER > 1
```

Figure 133-2

```
0 EXIT          3 CANCEL PROGRAM  
1 SAVE PROGRAM 4 RUN THEN DELETE  
2 SAVE PROGRAM AND RUN  
PRESS NUMBER >
```

Figure 133-3

```
STORED PROGRAMS  
PRESS NUMBER FROM 1 TO 17 TO SAVE.  
ENTER PROGRAM NUMBER >
```

Figure 133-4

```
PROGRAM X SAVED  
PRESS ANY KEY >
```

Figure 133-5

Step Program Examples

Example 8. Program with Percent-of-Percent Timer or Percent-of-Depth

In this example, the Percent Timer will be programmed to 50% of its current setting when the wind speed exceeds 20 mph. This action is not dependent on such things as direction, position, time of day, etc.

Current Conditions:

- Machine running, 60%, water on

Program Machine By:

- Wind speed equal to or greater than 20 mph - 50% of 60%

Start Programming

To program Example 8, follow these steps.

- Press **PROGRAM**, **1** for STEP PROGRAMS.
- Press **2** for CREATE NEW.

Program STEP 1 - Example 8

- To program with percent of Percent Timer or Depth, press **6**, **6**, **1**. See Figure 134-1.
 - Press **2**, **0** to enter wind speed, and press **ENTER**. See Figure 134-2.
 - Press **1** for HIGHER. See Figure 134-3.
 - Press **OPTIONS**, **8**, **2** for PERCENT. See Figure 134-4.
 - Press **0** for %-OF-% (percent of percent). See Figure 134-5.
- NOTE: As shown in Figure 134-5, you can alternately choose to specify a percent of the depth setting by pressing **1** for %-OF-DEPTH (percent of depth).**
- Press **5**, **0** for 50 percent. See Figure 134-6.

```
STEP 1 PROGRAM BY:
0 EXIT      2 TEMP
1 WIND      3 RAIN
PRESS NUMBER > 1
```

Figure 134-1

```
STEP 1 PROGRAM BY: WIND
ENTER WIND SPEED ( 1 ) > 20
```

Figure 134-2

```
STEP 1 PROGRAM BY: WIND
1..HIGHER  0..LOWER > 1
```

Figure 134-3

```
0 EXIT      3 START$  6 MODULE
1 END-GUNS  4 STOP$   7 VRI
2 PERCENT   5 CYCLE$
PRESS NUMBER > 2
```

Figure 134-4

```
0 EXIT      3 START$  6 MODULE
1 END-GUNS  4 STOP$   7 VRI
2 PERCENT   5 CYCLE$
PRESS 0..%-OF-% 1..%-OF-DEPTH
```

Figure 134-5

```
0 EXIT      3 START$  6 MODULE
1 END-GUNS  4 STOP$   7 VRI
2 PERCENT   5 CYCLE$
ENTER % OF SPEED > 50
```

Figure 134-6

Example 8. Program with Percent-of-Percent Timer or Percent-of-Depth (continued)

9. Finish by pressing . See Figure 135-1.
10. Finish the program by pressing for PROGRAM FINISHED. See Figure 135-2.
11. Select one of the following. See Figures 135-3, 135-4, and 135-5.
 - Press for SAVE PROGRAM.
 - (a) Select program number 1-17.
 - (b) Press to save the program.
 - Press for SAVE PROGRAM AND RUN.
 - (c) Select program number 1-17.
 - (d) Press to save and run the program.
 - Press for CANCEL PROGRAM to cancel the program.
 - Press for RUN THEN DELETE to run the program once and then delete it.

As a result of this program, when the wind speed hits 20 mph the Percent Timer will be adjusted from 60% to 30%. This may help reduce water loss.

```
STEP 1 AT: WIND HIGHER THAN 20 MPH  
50% OF SPEED,  
  
ENTER COMMANDS, FINISHED..PRESS ENTER
```

Figure 135-1

```
0 EXIT  
1 PROGRAM FINISHED  
2 NEXT STEP  
PRESS NUMBER > 1
```

Figure 135-2

```
0 EXIT                3 CANCEL PROGRAM  
1 SAVE PROGRAM       4 RUN THEN DELETE  
2 SAVE PROGRAM AND RUN  
PRESS NUMBER >
```

Figure 135-3

```
STORED PROGRAMS  
  
PRESS NUMBER FROM 1 TO 17 TO SAVE.  
ENTER PROGRAM NUMBER >
```

Figure 135-4

```
PROGRAM X SAVED  
  
PRESS ANY KEY >
```

Figure 135-5

Step Program Examples

Example 9. Program with Enable/Disable End Guns

In this example, the end gun will be disabled when the wind speed exceeds 20 mph. This action is not dependent on such things as direction, position, time of day, etc.

Current Conditions:



- Machine running, water on, end gun enabled.

Program Machine By:













- Wind speed equal to or greater than 20 mph - end gun disabled

Start Programming

To program Example 9, follow these steps.

1. Press ,  for STEP PROGRAMS.
2. Press  for CREATE NEW.

Program STEP 1 - Example 9

3. To program with wind speed with enable/disable End Guns, press , , . See Figure 136-1.
4. Press ,  to enter wind speed, and press . See Figure 136-2.
5. Press  for HIGHER. See Figure 136-3.
6. To program with enable/disable End Guns, press , , , for END-GUNS. See Figure 136-4.
7. Press , ,  for END-GUN and DISABLE. See Figure 136-5.

NOTE: As shown in Figure 136-2, you can alternately choose to enable/disable Wide Boundary, PLC Wide Boundary 2, or Wide Boundary 3.

8. Finish by pressing . See Figure 136-6.

```
STEP 1 PROGRAM BY:  
0 EXIT      2 TEMP  
1 WIND      3 RAIN  
PRESS NUMBER > 1
```

Figure 136-1

```
STEP 1 PROGRAM BY: WIND  
  
ENTER WIND SPEED ( 1 ) > 20
```

Figure 136-2

```
STEP 1 PROGRAM BY: WIND  
  
1..HIGHER  0..LOWER > 1
```

Figure 136-3

```
0 EXIT          3 START$    6 MODULE  
1 END-GUNS      4 STOP$      7 VRI  
2 PERCENT       5 CYCLE$  
PRESS NUMBER > 1
```

Figure 136-4

```
0 EXIT          3 PLC WIDE BND#2  
1 END-GUN       4 PLC WIDE BND#3  
2 WIDE BND  
END-GUN 1..ENABLE 0..DISABLE (0) >
```

Figure 136-5

```
STEP 1 AT: WIND HIGHER THAN 20 MPH  
50% OF SPEED,  
  
ENTER COMMANDS, FINISHED..PRESS ENTER
```

Figure 136-6

Example 9. Program with Enable/Disable End Guns (continued)

9. Finish the program by pressing **1** for PROGRAM FINISHED. See Figure 137-1.
10. Select one of the following. See Figures 137-2, 137-3, and 137-4.
 - Press **1** for SAVE PROGRAM.
 - (a) Select program number 1-17.
 - (b) Press **ENTER** to save the program.
 - Press **2** for SAVE PROGRAM AND RUN.
 - (c) Select program number 1-17.
 - (d) Press **ENTER** to save and run the program.
 - Press **3** for CANCEL PROGRAM to cancel the program.
 - Press **4** for RUN THEN DELETE to run the program once and then delete it.

```
0 EXIT
1 PROGRAM FINISHED
2 NEXT STEP
PRESS NUMBER > 1
```

Figure 137-1

```
0 EXIT          3 CANCEL PROGRAM
1 SAVE PROGRAM  4 RUN THEN DELETE
2 SAVE PROGRAM AND RUN
PRESS NUMBER >
```

Figure 137-2

```
STORED PROGRAMS

PRESS NUMBER FROM 1 TO 17 TO SAVE.
ENTER PROGRAM NUMBER >
```

Figure 137-3

```
PROGRAM X SAVED

PRESS ANY KEY >
```

Figure 137-4

Step Program Examples

Example 10. Program with Enable/Disable Cruise Control

In this example, the Cruise Control hours will be increased when the wind speed exceeds 20 mph. This action is not dependent on such things as direction, position, time of day, etc.

Current Conditions:

- Machine running, water on, Cruise Control set at 48 hours.

Program Machine By:

- Wind speed equal to or greater than 20 mph - Cruise Control set at 72 hours

NOTE: When Cruise Control is enabled, VRI-Speed is automatically turned off.

Start Programming

To program Example 10, follow these steps.

1. Press **PROGRAM**, **1** for STEP PROGRAMS.
2. Press **2** for CREATE NEW.

Program STEP 1 - Example 10

3. To program wind speed with enable/disable Cruise Control, press **6**, **6**, **1**. See Figure 138-1.

4. Press **2**, **0** to enter wind speed, and press **ENTER**. See Figure 138-2.

5. Press **1** for HIGHER. See Figure 138-3.

6. Press **OPTIONS**, **5** for CRUISE CONTROL. See Figure 138-4.

7. Press **1** for ENABLE, and press **ENTER**. See Figure 138-5.

NOTE: Press **0** if you want to DISABLE Cruise Control.

8. Press **7**, **2** to increase the number of hours from 48 to 72. See Figure 138-6.

```
STEP 1 PROGRAM BY:  
0 EXIT 2 TEMP  
1 WIND 3 RAIN  
PRESS NUMBER > 1
```

Figure 138-1

```
STEP 1 PROGRAM BY: WIND  
  
ENTER WIND SPEED ( 1 ) > 20
```

Figure 138-2

```
STEP 1 PROGRAM BY: WIND  
  
1..HIGHER 0..LOWER > 1
```

Figure 138-3

```
0 EXIT 3 LOGGING EVENT 6 AR/AS  
1 AUX1 4 NA 7 AUTORESTART  
2 AUX2 5 CRUISE CONTROL 8 OTHER  
PRESS NUMBER > 5
```

Figure 138-4









```
0 EXIT 3 LOGGING EVENT 6 AR/AS  
1 AUX1 4 NA 7 AUTORESTART  
2 AUX2 5 CRUISE CONTROL 8 OTHER  
CRUISE 1..ENABLE 0..DISABLE (1) > 1
```

Figure 138-5

```
0 EXIT 3 LOGGING EVENT 6 AR/AS  
1 AUX1 4 NA 7 AUTORESTART  
2 AUX2 5 CRUISE CONTROL 8 OTHER  
ENTER HOURS ( 48.0 ) > 72
```

Figure 138-6

Example 10. Program with Enable/Disable Cruise Control (continued)

9. Finish by pressing . See Figure 139-1.
NOTE: If you choose to disable Cruise Control in Step 7, the display will appear as it does in Figure 139-2.
10. Finish the program by pressing  for PROGRAM FINISHED. See Figure 139-3.
11. Select one of the following. See Figures 139-4, 139-5, and 139-6.
- Press  for SAVE PROGRAM.
 - (a) Select program number 1-17.
 - (b) Press  to save the program.
 - Press  for SAVE PROGRAM AND RUN.
 - (c) Select program number 1-17.
 - (d) Press  to save and run the program.
 - Press  for CANCEL PROGRAM to cancel the program.
 - Press  for RUN THEN DELETE to run the program once and then delete it.

```
STEP 1 AT: WIND HIGHER THAN 20 MPH  
CRUISE 72.0 HRS,  
  
ENTER COMMANDS, FINISHED..PRESS ENTER
```

Figure 139-1

```
STEP 1 AT: WIND HIGHER THAN 20 MPH  
CRUISE DISABLED,  
  
ENTER COMMANDS, FINISHED..PRESS ENTER
```

Figure 139-2

```
0 EXIT  
1 PROGRAM FINISHED  
2 NEXT STEP  
PRESS NUMBER > 1
```

Figure 139-3

```
0 EXIT                3 CANCEL PROGRAM  
1 SAVE PROGRAM       4 RUN THEN DELETE  
2 SAVE PROGRAM AND RUN  
PRESS NUMBER >
```

Figure 139-4

```
STORED PROGRAMS  
  
PRESS NUMBER FROM 1 TO 17 TO SAVE.  
ENTER PROGRAM NUMBER >
```

Figure 139-5

```
PROGRAM X SAVED  
  
PRESS ANY KEY >
```

Figure 139-6

Step Program Examples

Example 11. Program with VRI ON/OFF

In this example, VRI will be disabled when the wind speed exceeds 20 mph. At that point, Cruise Control will be enabled and set at 72 hours. This action is not dependent on such things as direction, position, time of day, etc.

Current Conditions:

- Machine running, water on, VRI enabled

Program Machine By:

- Wind speed equal to or greater than 20 mph - VRI off, Cruise Control enabled and set at 72 hours

NOTE: When VRI is enabled, Cruise Control is automatically turned off.

Start Programming

To program Example 11, follow these steps.

1. Press **PROGRAM**, **1** for STEP PROGRAMS.
2. Press **2** for CREATE NEW.

Program STEP 1 - Example 11

3. To program wind speed with enable/disable Cruise Control and VRI off, press **6**, **6**, **1**. See Figure 140-1.
4. Press **2**, **0** to enter wind speed, and press **ENTER**. See Figure 140-2.
5. Press **1** for HIGHER. See Figure 140-3.
6. Press **OPTIONS**, **8**, **7** for VRI. See Figure 140-4.
7. Press **0** for VRI OFF. See Figure 140-5.
8. Press **OPTIONS**, **5**, **1** for Cruise Control ENABLE. See Figure 140-6.

```
STEP 1 PROGRAM BY:  
0 EXIT      2 TEMP  
1 WIND      3 RAIN  
PRESS NUMBER > 1
```

Figure 140-1

```
STEP 1 PROGRAM BY: WIND  
  
ENTER WIND SPEED ( 1 ) > 20
```

Figure 140-2

```
STEP 1 PROGRAM BY: WIND  
  
1..HIGHER  0..LOWER > 1
```

Figure 140-3

```
0 EXIT      3 START$  6 MODULE  
1 END-GUNS  4 STOP$   7 VRI  
2 PERCENT  5 CYCLE$  
PRESS NUMBER > 7
```

Figure 140-4

```
0 EXIT      3 START$  6 MODULE  
1 END-GUNS  4 STOP$   7 VRI  
2 PERCENT  5 CYCLE$  
VRI ( ON) 1..ON  0..OFF > 0
```

Figure 140-5

```
0 EXIT  3 LOGGING EVENT  6 AR/AS  
1 AUX1  4 NA              7 AUTORESTART  
2 AUX2  5 CRUISE CONTROL  8 OTHER  
CRUISE 1..ENABLE 0..DISABLE (1) > 1
```

Figure 140-6

Step Program Examples

Example 11. Program with VRI ON/OFF (continued)

9. Press **7**, **2** to increase the number of hours from 48 to 72. See Figure 141-1.
10. Finish by pressing **ENTER**. See Figure 141-2.
11. Finish the program by pressing **1** for PROGRAM FINISHED. See Figure 141-3.
12. Select one of the following. See Figures 141-4, 141-5, and 141-6.
 - Press **1** for SAVE PROGRAM.
 - (a) Select program number 1-17.
 - (b) Press **ENTER** to save the program.
 - Press **2** for SAVE PROGRAM AND RUN.
 - (c) Select program number 1-17.
 - (d) Press **ENTER** to save and run the program.
 - Press **3** for CANCEL PROGRAM to cancel the program.
 - Press **4** for RUN THEN DELETE to run the program once and then delete it.

```
0 EXIT 3 LOGGING EVENT 6 AR/AS
1 AUX1 4 NA 7 AUTORESTART
2 AUX2 5 CRUISE CONTROL 8 OTHER
ENTER HOURS ( 48.0) > 72
```

Figure 141-1

```
STEP 1 AT: WIND HIGHER THAN 20 MPH
VRI OFF, CRUISE 72.0 HRS,
ENTER COMMANDS, FINISHED..PRESS ENTER
```

Figure 141-2

```
0 EXIT
1 PROGRAM FINISHED
2 NEXT STEP
PRESS NUMBER > 1
```

Figure 141-3

```
0 EXIT 3 CANCEL PROGRAM
1 SAVE PROGRAM 4 RUN THEN DELETE
2 SAVE PROGRAM AND RUN
PRESS NUMBER >
```

Figure 141-4

```
STORED PROGRAMS
PRESS NUMBER FROM 1 TO 17 TO SAVE.
ENTER PROGRAM NUMBER >
```

Figure 141-5

```
PROGRAM X SAVED
PRESS ANY KEY >
```

Figure 141-6

Step Program Examples

Example 12. Program for a Logging Event

In this example, every time the wind speed exceeds 25 mph, an entry will be made in the event log and displayed on the History Review screens.

Current Conditions:

- Machine running, water on, depth 0.75

Program Machine By:

- Wind speed equal to or greater than 25 mph

Start Programming

To program Example 12, follow these steps.

1. Press **PROGRAM**, **1** for STEP PROGRAMS.
2. Press **2** for CREATE NEW.

Program STEP 1 - Example 12

3. To program wind speed, press **6**, **6**, **1**. See Figure 142-1.
4. Press **2**, **5** to enter wind speed, and press **ENTER**. See Figure 142-2.
5. Press **1** for HIGHER. See Figure 142-3.
6. Press **OPTIONS**, **3** for LOGGING EVENT. See Figure 142-4.
7. Finish by pressing **ENTER**. See Figure 142-5.
8. Finish the program by pressing **1** for PROGRAM FINISHED. See Figure 142-6.

```
STEP 1 PROGRAM BY:  
0 EXIT      2 TEMP  
1 WIND      3 RAIN  
PRESS NUMBER > 1
```

Figure 142-1

```
STEP 1 PROGRAM BY: WIND  
  
ENTER WIND SPEED ( 1 ) > 25
```

Figure 142-2

```
STEP 1 PROGRAM BY: WIND  
  
1..HIGHER  0..LOWER > 1
```

Figure 142-3

```
0 EXIT  3 LOGGING EVENT  6 AR/AS  
1 AUX1  4 NA              7 AUTORESTART  
2 AUX2  5 CRUISE CONTROL  8 OTHER  
PRESS NUMBER >
```

Figure 142-4

```
STEP 1 AT: WIND HIGHER THAN 25 MPH  
LOG EVENT,  
  
ENTER COMMANDS, FINISHED..PRESS ENTER
```

Figure 142-5

```
0 EXIT  
1 PROGRAM FINISHED  
2 NEXT STEP  
PRESS NUMBER > 1
```

Figure 142-6

Example 12. Program for a Logging Event (continued)

9. Select one of the following. See Figures 143-1, 143-2, and 143-3.

- Press **1** for SAVE PROGRAM.
 - (a) Select program number 1-17.
 - (b) Press **ENTER** to save the program.
- Press **2** for SAVE PROGRAM AND RUN.
 - (c) Select program number 1-17.
 - (d) Press **ENTER** to save and run the program.
- Press **3** for CANCEL PROGRAM to cancel the program.
- Press **4** for RUN THEN DELETE to run the program once and then delete it.

```
0 EXIT          3 CANCEL PROGRAM
1 SAVE PROGRAM  4 RUN THEN DELETE
2 SAVE PROGRAM AND RUN
PRESS NUMBER >
```

Figure 143-1

```
STORED PROGRAMS

PRESS NUMBER FROM 1 TO 17 TO SAVE.
ENTER PROGRAM NUMBER >
```

Figure 143-2

```
PROGRAM X SAVED

PRESS ANY KEY >
```

Figure 143-3

Step Program Examples

Example 13. Using the Run Program Command

A stored program can be called upon to run from within other programs. For example, program #2 could be run in the last step of program #1, program #3 could be run from program #2, etc. In this example program #1 runs program #2 to repeat the irrigation cycle and then stop at the SIS location. See Figure 144-1.

Current Conditions:

- Machine RUNNING at 0°, FORWARD, WATER ON, Depth 1.00", stop-in-slot is OFF and set at 0°.

Program Machine By:

Program 1

- Position: At 180°, WATER OFF, Percent 100.
- Position: At 225°, WATER ON, Depth 0.75", Run program #2. (Program #2 was already written and stored).

To program Example 13, follow these steps.

1. Start a new program.
1. Press **PROGRAM**, **1** for STEP PROGRAMS.
2. Press **2** for CREATE NEW.

Program STEP 1 - Example 13

3. To program the position, press **2** for POSITION. See Figures 144-2 and 144-3.
 - a) Press **1**, **8**, **0** for 180 degrees.
 - b) Press **ENTER** to retain 180 degrees.
4. Enter the commands to be executed at the position. See Figure 144-4.
 - a) Press **WATER OFF**.
 - b) Press **PERCENT**.
 - c) Press **1**, **0**, **0** for 100 percent.
 - d) Press **ENTER** to retain 100 percent.
5. Finish STEP 1 by pressing **ENTER**.
6. Press **2** for NEXT STEP. See Figure 144-5.

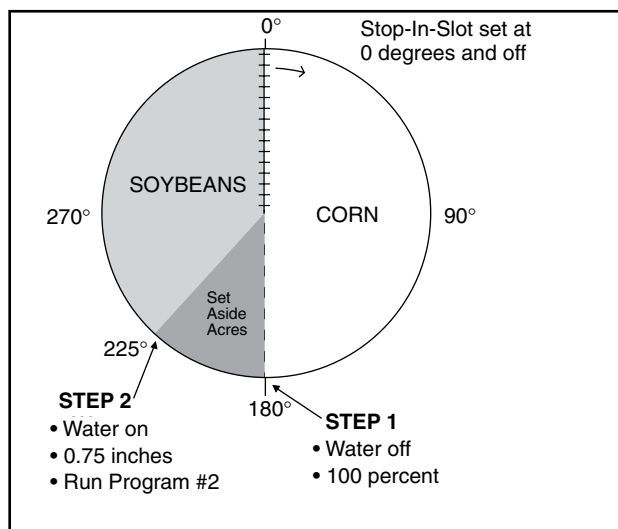

Figure 144-1

```
STEP 1 PROGRAM BY: POSITION
ENTER DEGREES ( 90.0 ) > 180
```

Figure 144-2

```
STEP 1 AT: 180.0 DEGREES,
ENTER COMMANDS, FINISHED..PRESS ENTER
```

Figure 144-3

```
STEP 1 AT: 180.0 DEGREES, WATER OFF
PERCENT 100,
ENTER COMMANDS, FINISHED..PRESS ENTER
```

Figure 144-4

```
0 EXIT
1 PROGRAM FINISHED
2 NEXT STEP
PRESS NUMBER > 2
```

Figure 144-5

Example 13. Using the Run Program Command (continued)

Program STEP 2 - Example 13

7. To program the next position, press for POSITION. See Figures 145-1 and 145-2.
 - a) Press , , for 225 degrees.
 - b) Press to retain 225 degrees.
8. Enter the commands to be executed at this position. See Figure 145-3.
 - a) Press .
 - b) Press .
 - c) Press , , for 0.75 inches.
 - d) Press to retain 0.75 inches.
 - e) Press .
 - f) Press for program 2.
 - g) Press to retain program 2.
9. Finish STEP 2 by pressing .

```
STEP 2 PROGRAM BY: POSITION
```

```
ENTER DEGREES ( 90.0) > 225
```

Figure 145-1

```
STEP 2 AT: 225.0 DEGREES,
```

```
ENTER COMMANDS, FINISHED..PRESS ENTER
```

Figure 145-2

```
STEP 2 AT: 225.0 DEGREES, WATER ON,  
DEPTH 0.75, RUN PROGRAM 2,
```

```
ENTER COMMANDS, FINISHED..PRESS ENTER
```

Figure 145-3

Finish Programming

10. Finish the program by pressing for PROGRAM FINISHED. See Figure 145-4.
11. Select one of the following. See Figures 145-5, 145-6, and 145-7.
 - Press for SAVE PROGRAM.
 - (a) Select program number 1-17.
 - (b) Press to save the program.
 - Press for SAVE PROGRAM AND RUN.
 - (c) Select program number 1-17.
 - (d) Press to save and run the program.
 - Press for CANCEL PROGRAM to cancel the program.
 - Press for RUN THEN DELETE to run the program once and then delete it.

```
0 EXIT  
1 PROGRAM FINISHED  
2 NEXT STEP  
PRESS NUMBER > 1
```

Figure 145-4

```
0 EXIT          3 CANCEL PROGRAM  
1 SAVE PROGRAM  4 RUN THEN DELETE  
2 SAVE PROGRAM AND RUN  
PRESS NUMBER >
```

Figure 145-5

```
STORED PROGRAMS 2  
  
PRESS NUMBER FROM 1 TO 17 TO SAVE.  
ENTER PROGRAM NUMBER > X
```

Figure 145-6

```
PROGRAM X SAVED  
  
PRESS ANY KEY >
```

Figure 145-7

Step Program Examples

Example 13. Using the Run Program Command (continued)

Program Execution

The programs are executed as outlined below:

Program 1

STEP 1: At 180° the machine changes the percentage timer setting to 100 percent, and the water is shut off.

STEP 2: At 225° the water is turned back on and applied at a depth of 0.75" on the soybeans. Program #2 is then loaded and run.

Program 2 (stored program)

STEP 1: At 0° with water already on the depth is set to 1.00".

STEP 2: At 180° turn auxiliary relay #1 off, turn the water off, and turn the stop-in-slot ON at 180°.

STEP 3: At 225° turn water on, set depth to 0.75", and turn stop-in-slot ON.

The machine runs forward with water on applied at a depth of 0.75", then shuts off at 0° which is the stop-in-slot location.

Repeating Irrigation Cycles

Example 1. Continuous Auto REVERSE Cycles

In this example, a machine is programmed to continuously auto reverse between positions. See Figure 147-1.

⚠ CAUTION

• THIS PROGRAM SHOULD ONLY BE USED FOR AUTO-REVERSING IN OPEN FIELD CONDITIONS WITH NO OBSTACLES PRESENT. IF THE MACHINE NEEDS TO REVERSE AROUND AN OBSTACLE SUCH AS A TREE LINE, BUILDING, OR FENCE, THEN A DRIVE UNIT MOUNTED END-OF-FIELD STOP/AUTO-REVERSE MUST BE INSTALLED WITH PHYSICAL BARRICADES AS A SAFETY BACK-UP.

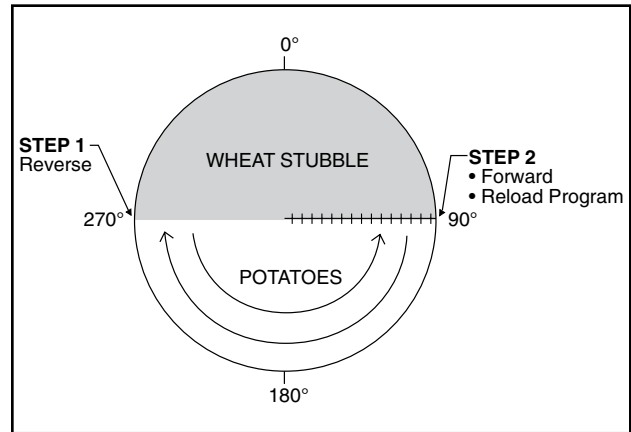

Figure 147-1

Current Conditions:

- Operator manually starts the machine, WATER ON, FORWARD, Depth 1.00".

Program Machine By:

- Position: At 270°, REVERSE.
- Position: At 90°, FORWARD, reload program so the machine reverses again at 270°.

Start Programming

To program Example 1, follow these steps.

1. Press **PROGRAM**, **1** for STEP PROGRAMS.
2. Press **2** for CREATE NEW.

Program STEP 1 - Example 1

3. To program the position, press **2** for POSITION. See Figures 147-2 and 147-3.
 - a) Press **1**, **8**, **0** for 270 degrees.
 - b) Press **ENTER** to retain 270 degrees.
4. Enter the command to be executed at this position. See Figure 147-4.
 - a) Press **REVERSE**.
5. Finish STEP 1 by pressing **ENTER**.
6. Press **2** for NEXT STEP. See Figure 147-5.

STEP 1 PROGRAM BY: POSITION

ENTER DEGREES (90.0) > 270

Figure 147-2

STEP 1 AT: 270.0 DEGREES,

ENTER COMMANDS, FINISHED..PRESS ENTER

Figure 147-3

STEP 1 AT: 270.0 DEGREES, REVERSE,

ENTER COMMANDS, FINISHED..PRESS ENTER

Figure 147-4

0 EXIT

1 PROGRAM FINISHED

2 NEXT STEP

PRESS NUMBER > 2

Figure 147-5

Step Program Examples

Repeating Irrigation Cycles

Example 1. Continuous Auto REVERSE Cycles (continued)

Program STEP 2 - Example 1

7. To program the next position, press **2** for POSITION. See Figures 148-1 and 148-2.

a) Press **9**, **0** for 90 degrees.

b) Press **ENTER** to retain 90 degrees.

8. Enter the commands to be executed at this position. See Figure 148-3.

a) Press **FORWARD**.

b) Press **PROGRAM**.

c) Select the stored program number to run. For this example use stored program 1.

d) Press **1** for stored program 1.

9. Finish STEP 2 by pressing **ENTER**.

```
STEP 2 PROGRAM BY: POSITION
ENTER DEGREES (270.0) > 90
```

Figure 148-1

```
STEP 2 AT: 90.0 DEGREES,
ENTER COMMANDS, FINISHED..PRESS ENTER
```

Figure 148-2

```
STEP 2 AT: 90.0 DEGREES, FORWARD,
RUN PROGRAM 1,
ENTER COMMANDS, FINISHED..PRESS ENTER
```

Figure 148-3

Finish Programming

10. Finish the program by pressing **1** for PROGRAM FINISHED. See Figure 148-4.

11. Select one of the following. See Figures 148-5, 148-6, and 148-7.

• Press **1** for SAVE PROGRAM.

(a) Select program number 1-17.

(b) Press **ENTER** to save the program.

• Press **2** for SAVE PROGRAM AND RUN.

(c) Select program number 1-17.

(d) Press **ENTER** to save and run the program.

• Press **3** for CANCEL PROGRAM to cancel the program.

• Press **4** for RUN THEN DELETE to run the program once and then delete it.

```
0 EXIT
1 PROGRAM FINISHED
2 NEXT STEP
PRESS NUMBER > 1
```

Figure 148-4

```
0 EXIT          3 CANCEL PROGRAM
1 SAVE PROGRAM  4 RUN THEN DELETE
2 SAVE PROGRAM AND RUN
PRESS NUMBER >
```

Figure 148-5

```
STORED PROGRAMS
PRESS NUMBER FROM 1 TO 17 TO SAVE.
ENTER PROGRAM NUMBER >
```

Figure 148-6

```
PROGRAM 1 SAVED
PRESS ANY KEY >
```

Figure 148-7

Repeating Irrigation Cycles

Example 1. Continuous Auto REVERSE Cycles (continued)

Running The Program

To run the program use run stored or save and run program. Either of these methods make the program current.

When the machine is started, the program runs and the machine continues to operate until the program is deleted from current programs, Stop-In Slot or another program stops the machine, or STOP is pressed.

The only purpose of this program is to change machine direction at 90° and 270°.

This program can run simultaneously with other programs that may start or stop the machine, or change water application depth.

⚠ CAUTION

•PROGRAM STEPS ARE EXECUTED IN NUMERIC ORDER. IN THIS EXAMPLE, THE MACHINE MUST TRAVEL TOWARD 270° FIRST AND THEN TOWARD 90°. IF THE DIRECTION OF THE MACHINE IS MANUALLY REVERSED AND THE MACHINE HAS NOT EXECUTED THE CURRENT STEP, THE MACHINE WILL NOT REVERSE PROPERLY.

If the direction of the machine is manually changed from FORWARD to REVERSE before STEP #1 is executed, the following happens.

- The machine travels past 90° in the REVERSE direction to 270°, which is not desired. See Figure 149-1.
- Step #1 is executed but the direction of the machine does not change because it is already travelling in the REVERSE direction.
- Step #2 is executed normally at 90°, the direction of the machine changes to FORWARD, and the program is reloaded.

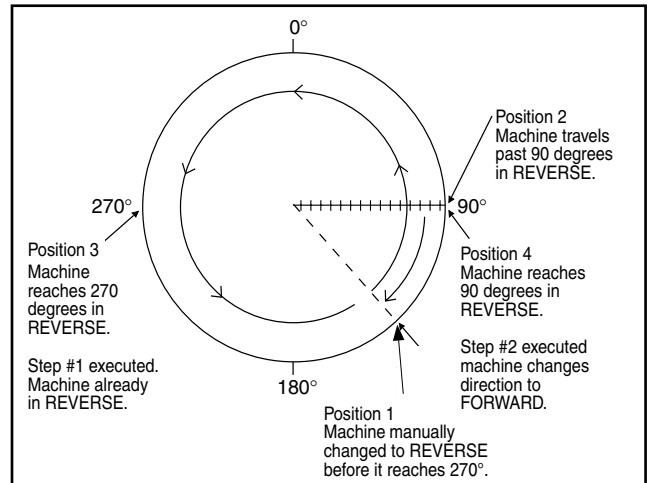

Figure 149-1

Step Program Examples

Repeating Irrigation Cycles

Example 2. Continuous Wet Area Water OFF Cycles

This example illustrates how to turn the water off and change percentage setting, and then turn the water back on and change percentage setting again. This program allows the machine to travel without water at 100 percent over a wet area. Reloading this program in the last step causes this program to be repeated continuously. See Figure 150-1.

Current Conditions:

- Operator manually starts the machine, WATER ON, FORWARD, 50 percent.

Program Machine By:

- Position: At 90°, WATER OFF, Percent 100.
- Position: At 105°, WATER ON, Percent 50, Reload this program.

Start Programming

To program Example 2, follow these steps.

1. Press **PROGRAM**, **1** for STEP PROGRAMS.
2. Press **2** for CREATE NEW.

Program STEP 1 - Example 2

3. To program the position, press **2** for POSITION. See Figures 150-2 and 150-3.
 - a) Press **9**, **0** for 90 degrees.
 - b) Press **ENTER** to retain 90 degrees.
4. Enter the commands to be executed at this position. See Figure 150-4.
 - a) Press **WATER OFF**.
 - b) Press **PERCENT**.
 - c) Press **1**, **0**, **0** for 100 percent.
 - d) Press **ENTER** to retain 100 percent.
5. Finish STEP 1 by pressing **ENTER**.
6. Press **2** for NEXT STEP. See Figure 150-5.

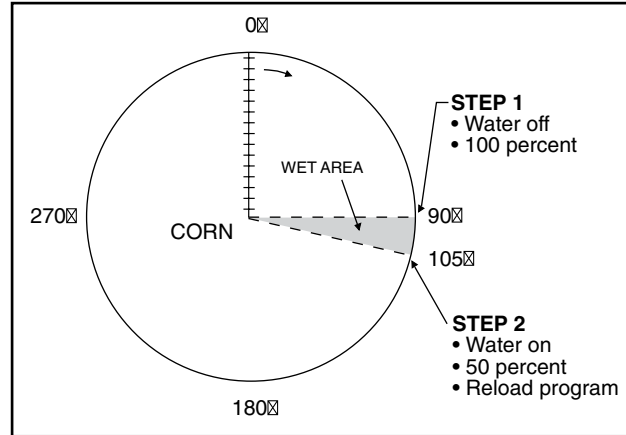

Figure 150-1

```
STEP 1 PROGRAM BY: POSITION
ENTER DEGREES ( 180.0 ) > 90
```

Figure 150-2

```
STEP 1 AT: 90.0 DEGREES,
ENTER COMMANDS, FINISHED..PRESS ENTER
```

Figure 150-3

```
STEP 1 AT: 90.0 DEGREES, WATER OFF,
PERCENT 100,
ENTER COMMANDS, FINISHED..PRESS ENTER
```

Figure 150-4

```
0 EXIT
1 PROGRAM FINISHED
2 NEXT STEP
PRESS NUMBER > 2
```

Figure 150-5

Repeating Irrigation Cycles

Example 2. Continuous Wet Area Water OFF Cycles (continued)

Program STEP 2 - Example 2

7. To program the next position, press **2** for POSITION. See Figures 151-1 and 151-2.
 - a) Press **1**, **0**, **5** for 105 degrees.
 - b) Press **ENTER** to retain 105 degrees.
8. Enter the commands to be executed at this position. See Figure 151-3.
 - a) Press **WATER ON**.
 - b) Press **PERCENT**.
 - c) Press **5**, **0** for 50 percent.
 - d) Press **ENTER** to retain 50 percent.
 - e) Press **PROGRAM**.
 - f) Select the stored program number to run. For this example, press **2** for stored program 2.
9. Finish STEP 2 by pressing **ENTER**.

```
STEP 2 PROGRAM BY: POSITION
ENTER DEGREES ( 180.0) > 105
```

Figure 151-1

```
STEP 2 AT: 105.0 DEGREES,
ENTER COMMANDS, FINISHED..PRESS ENTER
```

Figure 151-2

```
STEP 2 AT: 105.0 DEGREES, WATER ON,
PERCENT 50, RUN PROGRAM 2,
ENTER COMMANDS, FINISHED..PRESS ENTER
```

Figure 151-3

Finish Programming

10. Finish the program by pressing **1** for PROGRAM FINISHED. See Figure 151-4.
11. Select one of the following. See Figures 151-5, 151-6, and 151-7.
 - Press **1** for SAVE PROGRAM.
 - (a) Select program number 1-17.
 - (b) Press **ENTER** to save the program.
 - Press **2** for SAVE PROGRAM AND RUN.
 - (c) Select program number 1-17.
 - (d) Press **ENTER** to save and run the program.
 - Press **3** for CANCEL PROGRAM to cancel the program.
 - Press **4** for RUN THEN DELETE to run the program once and then delete it.

```
0 EXIT
1 PROGRAM FINISHED
2 NEXT STEP
PRESS NUMBER > 1
```

Figure 151-4

```
0 EXIT          3 CANCEL PROGRAM
1 SAVE PROGRAM  4 RUN THEN DELETE
2 SAVE PROGRAM AND RUN
PRESS NUMBER >
```

Figure 151-5

```
STORED PROGRAMS
PRESS NUMBER FROM 1 TO 17 TO SAVE.
ENTER PROGRAM NUMBER >
```

Figure 151-6

```
PROGRAM X SAVED
PRESS ANY KEY >
```

Figure 151-7

Step Program Examples

Repeating Irrigation Cycles

Example 3. Using Run Program Command

In this example, the machine needs to complete two identical irrigation cycles and stop at 0°. To accomplish this, two programs are written. See Figure 152-1.

Program #1 starts the machine at 3:00 am on 08/08/02, change the depth to 0.50" At 180°, change the depth to 1.00" At 0°, and load program two to complete the first cycle.

Program #2 changes the depth to 0.50" At 180° and stop the machine at 0° to complete the second cycle.

Program One

Expected Conditions - First Program:

- Machine OFF at 0°.

Program Machine By:

- Time: On 08/08/02 at 3:00:00 AM, FORWARD, Water On, Depth 1.00", Start.
- Position: At 180°, Depth 0.50".
- Position: At 0°, Depth 1.00", Run Program 2.

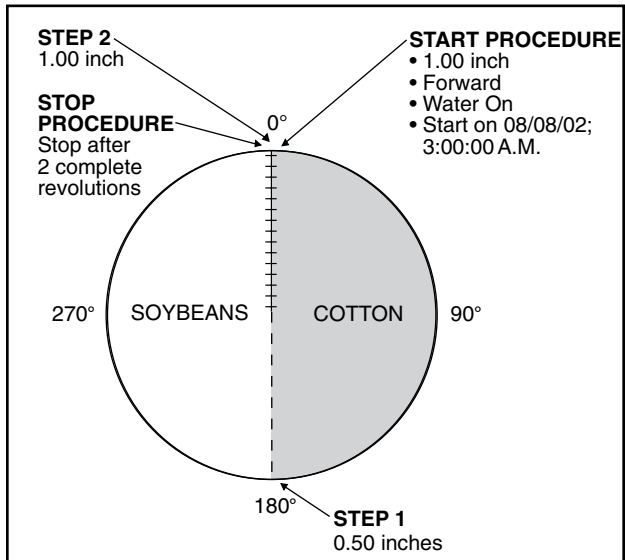

Figure 152-1

Start Programming

To write program one of Example 3, follow these steps.

1. Press **PROGRAM**, **1** for STEP PROGRAMS.
2. Press **2** for CREATE NEW.

Program STEP 1 - Example 3 - Program One

3. To program the date and time, press **1** for TIME.
4. Press **0** for DATE/TIME.
5. Press **0**, **8**, **0**, **8**, **0**, **2** for the date.
6. Press **ENTER**. See Figure 152-2.
7. Press **0**, **3**, **0**, **0**, **0**, **0** for 3:00 AM.
8. Press **ENTER**. See Figures 152-3 and 152-4.

```
STEP 1 PROGRAM BY: TIME
ENTER DATE (07/27/02) > 08/08/02
```

Figure 152-2

```
STEP 1 PROGRAM BY: TIME
ENTER TIME (08:04) > 03:00:00
```

Figure 152-3

```
STEP 1 AT: 08/08/02 03:00:00,
ENTER COMMANDS, FINISHED..PRESS ENTER
```

Figure 152-4

Repeating Irrigation Cycles

Example 3. Using Run Program Command (continued)

9. Enter the commands to be executed at that time. See Figure 153-1.

- a) Press .
- b) Press for 1.00 inch.
- c) Press to retain 1.00 inch.
- d) Press .
- e) Press .
- f) Press .

```
STEP 1 AT: 08/08/02 03:00:00
DEPTH 1.00, FORWARD, WATER ON, START,
ENTER COMMANDS, FINISHED..PRESS ENTER
```

Figure 153-1

10. Finish STEP 1 by pressing .

11. Press for NEXT STEP. See Figure 153-2.

Program STEP 2 - Example 3 - Program One

12. To program the position, press for POSITION. See Figure 153-3.

- a) Press , , for 180 degrees.
- b) Press to retain 180 degrees.

```
0 EXIT
1 PROGRAM FINISHED
2 NEXT STEP
PRESS NUMBER > 2
```

Figure 153-2

13. Enter the commands to be executed at this position. See Figure 153-4.

- a) Press .
- b) Press , , for 0.50 inch.
- c) Press to retain 0.50 inch.

```
STEP 2 PROGRAM BY: POSITION
ENTER DEGREES ( 90.0) > 180
```

Figure 153-3

14. Finish STEP 2 by pressing .

- a) Press for NEXT STEP. See Figure 153-5.

```
STEP 2 AT: 180.0 DEGREES, DEPTH 0.50,
ENTER COMMANDS, FINISHED..PRESS ENTER
```

Figure 153-4

```
0 EXIT
1 PROGRAM FINISHED
2 NEXT STEP
PRESS NUMBER > 2
```

Figure 153-5

Step Program Examples

Repeating Irrigation Cycles

Example 3. Using Run Program Command (continued)

Program STEP 3 - Example 3 - Program One

15. To program the next position, press for POSITION. See Figures 154-1 and 154-2.

- a) Press for 0 degrees.
- b) Press to retain 0 degrees.

16. Enter the commands to be executed at this position. See Figure 154-3.

- a) Press .
- b) Press for 1 inch.
- c) Press to retain 1.00 inch.
- d) Press .
- e) Select the stored program number to run. For this example, press for stored program 2.

17. Finish STEP 3 by pressing .

Finish Programming

18. Finish the program by pressing for PROGRAM FINISHED. See Figure 154-4.

19. Select one of the following. See Figures 154-5, 154-6, and 154-7.

- Press for SAVE PROGRAM.
 - (a) Select program number 1-17.
 - (b) Press to save the program.
- Press for SAVE PROGRAM AND RUN.
 - (c) Select program number 1-17.
 - (d) Press to save and run the program.
- Press for CANCEL PROGRAM to cancel the program.
- Press for RUN THEN DELETE to run the program once and then delete it.

```
STEP 3 PROGRAM BY: POSITION
ENTER DEGREES ( 180.0) > 0
```

Figure 154-1

```
STEP 3 AT: 0.0 DEGREES,
ENTER COMMANDS, FINISHED..PRESS ENTER
```

Figure 154-2

```
STEP 3 AT: 0.0 DEGREES, DEPTH 1.00,
RUN PROGRAM 2,
ENTER COMMANDS, FINISHED..PRESS ENTER
```

Figure 154-3

```
0 EXIT
1 PROGRAM FINISHED
2 NEXT STEP
PRESS NUMBER > 1
```

Figure 154-4

```
0 EXIT          3 CANCEL PROGRAM
1 SAVE PROGRAM  4 RUN THEN DELETE
2 SAVE PROGRAM AND RUN
PRESS NUMBER >
```

Figure 154-5

```
STORED PROGRAMS
PRESS NUMBER FROM 1 TO 17 TO SAVE.
ENTER PROGRAM NUMBER > 1
```

Figure 154-6

```
PROGRAM 1 SAVED
PRESS ANY KEY >
```

Figure 154-7

Repeating Irrigation Cycles

Example 3. Using Run Program Command (continued)

Create program two with two steps. Step 1 changes the water application to 0.50" at 180°, and STEP 2 stops the machine at 0°. See Figure 155-1.

Program Two

Expected Conditions - Program Two:

- Machine RUNNING at 0°.

Program Machine By:

- Position: At 180°, Depth 0.50".
- Position: At 0°, STOP.

Start Programming

To write the program two of Example 3, follow these steps.

1. Press **PROGRAM**, **1** for STEP PROGRAMS.
2. Press **2** for CREATE NEW.

Program STEP 1 - Example 3 - Program Two

3. To program the position, press **2** for POSITION.
 - a) Press **1**, **8**, **0** for 180 degrees. See Figure 155-2.
 - b) Press **ENTER** to retain 180 degrees.
4. Enter the commands to be executed at this position. See Figures 155-3 and 155-4.
 - a) Press **DEPTH**.
 - b) Press **.**, **5**, **0** for 0.50 inch.
 - c) Press **ENTER** to retain 0.50 inch.
5. Finish STEP 1 by pressing **ENTER**.
6. Press **2** for NEXT STEP. See Figure 155-5.

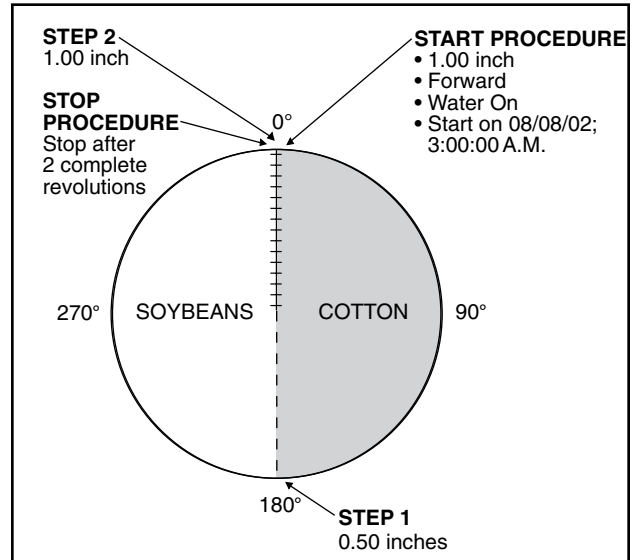

Figure 155-1

```
STEP 1 PROGRAM BY: POSITION
ENTER DEGREES ( 90.0 ) > 180
```

Figure 155-2

```
STEP 1 AT: 180.0 DEGREES,
ENTER COMMANDS, FINISHED..PRESS ENTER
```

Figure 155-3

```
STEP 1 AT: 180.0 DEGREES, DEPTH 0.50,
ENTER COMMANDS, FINISHED..PRESS ENTER
```

Figure 155-4

```
0 EXIT
1 PROGRAM FINISHED
2 NEXT STEP
PRESS NUMBER > 2
```

Figure 155-5

Step Program Examples

Repeating Irrigation Cycles

Example 3. Using Run Program Command (continued)

Program STEP 2 - Example 3 - Program Two

7. To program the next position, press **2** for POSITION. See Figures 156-1 and 156-2.

a) Press **0** for 0 degrees.

b) Press **ENTER** to retain 0 degrees.

8. Enter the command to be executed at this position. See Figure 156-3.

a) Press **STOP**.

9. Finish STEP 2 by pressing **ENTER**.

Finish Programming

10. Finish the program by pressing **1** for PROGRAM FINISHED. See Figure 156-4.

11. Select one of the following. See Figures 156-5, 156-6, and 156-7.

• Press **1** for SAVE PROGRAM.

(a) Select program number 1-17.

(b) Press **ENTER** to save the program.

• Press **2** for SAVE PROGRAM AND RUN.

(c) Select program number 1-17.

(d) Press **ENTER** to save and run the program.

• Press **3** for CANCEL PROGRAM to cancel the program.

• Press **4** for RUN THEN DELETE to run the program once and then delete it.

Program Operation

The programming for Example 3 is complete.

The machine starts on 08/08/02 at 3:00 AM, changes water application to 0.50" at 180°, changes water application to 1.00" at 0°, and then loads program #4. Program #4 changes the water application to 0.50" at 180° and stops the machine at 0°.

This sequence of events could have been programmed all in one program by adding steps 4 and 5 to the first program. However, this example was used to illustrate how one program could load another, and how it can be applied.

There could be 17 stored programs, with each one performing a different sequence of events. These could be run one right after the other by using the program command described in this example.

```
STEP 2 PROGRAM BY: POSITION  
  
ENTER DEGREES ( 90.0 ) > 0
```

Figure 156-1

```
STEP 2 AT: 0.0 DEGREES,  
  
ENTER COMMANDS, FINISHED..PRESS ENTER
```

Figure 156-2

```
STEP 2 AT: 0.0 DEGREES, STOP,  
  
ENTER COMMANDS, FINISHED..PRESS ENTER
```

Figure 156-3

```
0 EXIT  
1 PROGRAM FINISHED  
2 NEXT STEP  
PRESS NUMBER > 1
```

Figure 156-4

```
0 EXIT          3 CANCEL PROGRAM  
1 SAVE PROGRAM 4 RUN THEN DELETE  
2 SAVE PROGRAM AND RUN  
PRESS NUMBER >
```

Figure 156-5

```
STORED PROGRAMS 1,  
  
PRESS NUMBER FROM 1 TO 17 TO SAVE.  
ENTER PROGRAM NUMBER >
```

Figure 156-6

```
PROGRAM X SAVED  
  
PRESS ANY KEY >
```

Figure 156-7

Step Program Examples

Scheduled Irrigation Cycles

Example 1. Time Delay with Run Program Command

This example illustrates one way to write a series of step programs, one program per irrigation cycle with time delays between each program. Execute the series of programs by running program one, program two, and program three automatically as they are called upon. See Figure 157-1.

Current Conditions:

- Machine OFF at 0°.

Program Machine To:

- START on 08/08/02, at 3:00 AM, FORWARD, WATER On, Depth 1.00".
- Depth 0.75" at 180°.
- STOP machine at 0° after 3 complete irrigation cycles with a 2 day (2880 minute) delay in between each cycle.

Program One

STEP 1: At 3:00 AM on 08/08/02, WATER ON, Depth 1.00", FORWARD, START.

STEP 2: At 180°, Depth 0.75".

STEP 3: At 0°, STOP.

STEP 4: At 2880 Minutes Delay, WATER ON, Depth 1.00", FORWARD, START, Run Program #2.

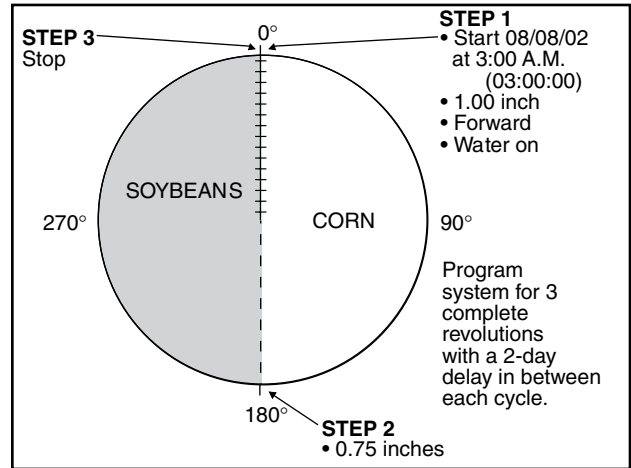

Figure 157-1

Start Programming

To write the first program of Example 1, follow these steps.

1. Press **PROGRAM**, **1** for STEP PROGRAMS.
2. Press **2** for CREATE NEW.

Program STEP 1 - Example 1 - Program One

3. To program the date and time, press **1** for TIME.
4. Press **0** for DATE/TIME.
5. Press **0**, **8**, **0**, **8**, **0**, **2** to enter the date.
6. Press **ENTER**. See Figure 157-2.
7. Press **0**, **3**, **0**, **0**, **0**, **0** for 3:00 AM.
8. Press **ENTER**. See Figures 157-3 and 157-4.
9. Enter the commands to be executed at that time. See Figure 157-5.
 - a) Press **WATER ON**.
 - b) Press **DEPTH**.
 - c) Press **1** for 1.00 inch.
 - d) Press **ENTER** to retain 1.00 inch.
 - e) Press **FORWARD**.
 - f) Press **START**.

```
STEP 1 PROGRAM BY: TIME
ENTER DATE (00/00/00) > 08/08/02
```

Figure 157-2

```
STEP 1 PROGRAM BY: TIME
ENTER TIME (00:00) > 03:00:00
```

Figure 157-3

```
STEP 1 AT: 08/08/02 03:00:00
ENTER COMMANDS, FINISHED..PRESS ENTER
```

Figure 157-4

```
STEP 1 AT: 08/08/02 03:00:00, WATER ON,
DEPTH 1.00,
FORWARD, START,
ENTER COMMANDS, FINISHED..PRESS ENTER
```

Figure 157-5

Step Program Examples

Scheduled Irrigation Cycles

Example 1. Time Delay with Run Program Command (continued)

10. Finish STEP 1 by pressing .

11. Press for NEXT STEP. See Figure 158-1.

Program STEP 2 - Example 1 - Program One

12. To program the position, press for POSITION. See Figures 158-2 and 158-3.

a) Press , , for 270 degrees.

b) Press to retain 270 degrees.

13. Enter the command to be executed at this position. See Figure 158-4.

a) Press .

b) Press , , for 0.75 inches.

c) Press to retain 0.75 inches.

14. Finish STEP 2 by pressing .

15. Press for NEXT STEP. See Figure 158-5.

Program STEP 3 - Example 1 - Program One

16. To program the next position, press for POSITION. See Figures 158-6 and 158-7.

a) Press for 0 degrees.

b) Press to retain 0 degrees.

```
0 EXIT
1 PROGRAM FINISHED
2 NEXT STEP
PRESS NUMBER > 2
```

Figure 158-1

```
STEP 2 PROGRAM BY: POSITION

ENTER DEGREES ( 90.0) > 180
```

Figure 158-2

```
STEP 2 AT: 180.0 DEGREES,

ENTER COMMANDS, FINISHED..PRESS ENTER
```

Figure 158-3

```
STEP 2 AT: 180.0 DEGREES, DEPTH 0.75,

ENTER COMMANDS, FINISHED..PRESS ENTER
```

Figure 158-4

```
0 EXIT
1 PROGRAM FINISHED
2 NEXT STEP
PRESS NUMBER > 2
```

Figure 158-5

```
STEP 3 PROGRAM BY: POSITION

ENTER DEGREES ( 90.0) > 0
```

Figure 158-6

```
STEP 3 AT: 0.0 DEGREES,

ENTER COMMANDS, FINISHED..PRESS ENTER
```

Figure 158-7

Scheduled Irrigation Cycles

Example 1. Time Delay with Run Program Command (continued)

17. Enter the command to be executed at this position. See Figure 159-1.

a) Press .

18. Finish STEP 3 by pressing .

19. Press for NEXT STEP. See Figure 159-2.

```
STEP 3 AT: 0.0 DEGREES, STOP,
ENTER COMMANDS, FINISHED..PRESS ENTER
```

Figure 159-1

Program STEP 4 - Example 1 - Program One

20. To program the delay time, press for DELAY. See Figures 159-3, 159-4, and 159-5.

a) Press for MINUTES.

b) Press , , , for 2880 minutes.

c) Press to retain 2880 minutes.

```
0 EXIT
1 PROGRAM FINISHED
2 NEXT STEP
PRESS NUMBER > 2
```

Figure 159-2

NOTE: A delay only counts as down time when the power is ON.

21. Enter the commands to be executed after the delay. See Figure 159-6.

a) Press .

b) Press .

c) Press for 1.00 inch.

d) Press to retain 1.00 inch.

e) Press .

f) Press .

g) Press .

h) Press for program 2.

i) Press to retain program 2.

```
STEP 4 PROGRAM BY: DELAY
DELAY 0..SECONDS 1..MINUTES > 1
```

Figure 159-3

```
STEP 4 PROGRAM BY: DELAY
ENTER DELAY IN MINUTES > 2880
```

Figure 159-4

```
STEP 4 AT: 2880 MINUTES DELAY,
ENTER COMMANDS, FINISHED..PRESS ENTER
```

Figure 159-5

```
STEP 4 AT: 2880 MINUTES DELAY,
WATER ON, DEPTH 1.00, FORWARD, START,
RUN PROGRAM 2,
ENTER COMMANDS, FINISHED..PRESS ENTER
```

Figure 159-6

22. Finish STEP 4 by pressing .

Step Program Examples

Scheduled Irrigation Cycles

Example 1. Time Delay with Run Program Command (continued)

Finish Programming

23. Finish program 1 by pressing for PROGRAM FINISHED. See Figure 160-1.
24. Press SAVE PROGRAM. See Figures 160-2, 160-3, and 160-4.
25. Press to select program number 1.
26. Press to save the program.

Program Two

- STEP 1: At 180°, Depth 0.75".
STEP 2: At 0°, STOP.
STEP 3: At 2880 Minutes Delay, WATER ON, Depth 1.00", FORWARD, START, run Program 3.

Start Programming

To write the second program of Example 1, follow these steps.

1. Press , for STEP PROGRAMS.
2. Press for CREATE NEW.

Program STEP 1 - Example 1 - Program Two

3. To program the position, press for POSITION. See Figures 160-5 and 160-6.
 - a) Press , , for 180 degrees.
 - b) Press to retain 180 degrees.
4. Enter the command to be executed at this position. See Figure 160-7.
 - a) Press .
 - b) Press , , for 0.75 inches.
 - c) Press to retain 0.75 inches.
5. Finish STEP 1 by pressing .
6. Press for NEXT STEP. See Figure 160-8.

```
0 EXIT
1 PROGRAM FINISHED
2 NEXT STEP
PRESS NUMBER > 1
```

Figure 160-1

```
0 EXIT          3 CANCEL PROGRAM
1 SAVE PROGRAM  4 RUN THEN DELETE
2 SAVE PROGRAM AND RUN
PRESS NUMBER > 1
```

Figure 160-2

```
STORED PROGRAMS

PRESS NUMBER FROM 1 TO 17 TO SAVE.
ENTER PROGRAM NUMBER > 1
```

Figure 160-3

```
PROGRAM 1 SAVED

PRESS ANY KEY >
```

Figure 160-4

```
STEP 1 PROGRAM BY: POSITION

ENTER DEGREES ( 90.0) > 180
```

Figure 160-5

```
STEP 1 AT: 180.0 DEGREES,

ENTER COMMANDS, FINISHED..PRESS ENTER
```

Figure 160-6

```
STEP 1 AT: 180.0 DEGREES, DEPTH 0.75,

ENTER COMMANDS, FINISHED..PRESS ENTER
```

Figure 160-7

```
0 EXIT
1 PROGRAM FINISHED
2 NEXT STEP
PRESS NUMBER > 2
```

Figure 160-8

Scheduled Irrigation Cycles

Example 1. Time Delay with Run Program Command (continued)

Program STEP 2 - Example 1 - Program Two

7. To program the position, press for POSITION. See Figures 161-1 and 161-2.
 - a) Press for 0 degrees.
 - b) Press to retain 0 degrees.
8. Enter the command to be executed at this position. See Figure 161-3.
9. Press .
10. Finish STEP 2 by pressing .
11. Press for NEXT STEP. See Figure 161-4.

Program STEP 3 - Example 1 - Program Two

12. To program the delay time, press for DELAY. See Figures 161-5, 161-6, and 161-7.
 - a) Press for MINUTES.
 - b) Press , , , for 2880 minutes.
 - c) Press to retain 2880 minutes.

NOTE: A delay only counts as down time when the power is ON.
13. Enter the commands to be executed after the delay. See Figure 161-8.
 - a) Press .
 - b) Press .
 - c) Press for 1.00 inch.
 - d) Press to retain 1.00 inch.
 - e) Press .
 - f) Press .
 - g) Press .
 - h) Press for program 3.
 - i) Press to retain program 3.
14. Finish STEP 3 by pressing .

```
STEP 2 PROGRAM BY: POSITION
ENTER DEGREES ( 90.0) > 0
```

Figure 161-1

```
STEP 2 AT: 0.0 DEGREES,
ENTER COMMANDS, FINISHED..PRESS ENTER
```

Figure 161-2

```
STEP 2 AT: 0.0 DEGREES, STOP,
ENTER COMMANDS, FINISHED..PRESS ENTER
```

Figure 161-3

```
0 EXIT
1 PROGRAM FINISHED
2 NEXT STEP
PRESS NUMBER > 2
```

Figure 161-4

```
STEP 3 PROGRAM BY: DELAY
DELAY 0..SECONDS 1..MINUTES > 1
```

Figure 161-5

```
STEP 3 PROGRAM BY: DELAY
ENTER DELAY IN MINUTES > 2880
```

Figure 161-6

```
STEP 3 AT: 2880 MINUTES DELAY,
ENTER COMMANDS, FINISHED..PRESS ENTER
```

Figure 161-7

```
STEP 3 AT: 2880 MINUTES DELAY,
WATER ON, DEPTH 1.00, FORWARD, START,
RUN PROGRAM 3,
ENTER COMMANDS, FINISHED..PRESS ENTER
```

Figure 161-8

Step Program Examples

Scheduled Irrigation Cycles

Example 1. Time Delay with Run Program Command (continued)

Finish Programming

15. Finish program 2 by pressing for PROGRAM FINISHED. See Figure 162-1.
16. Press SAVE PROGRAM. See Figures 162-2, 162-3, and 162-4.
17. Press to select program number 2.
18. Press to save the program.

Program Three

STEP 1: At 180°, Depth 0.75”.

STEP 2: At 0°, STOP.

Start Programming

To write the third program of example 1, follow these steps.

1. Press , for STEP PROGRAMS.
2. Press for CREATE NEW.

Program STEP 1 - Example 1 - Program Three

3. To program the position, press for POSITION. See Figures 162-5 and 162-6.
 - a) Press , , for 180 degrees.
 - b) Press to retain 180 degrees.
4. Enter the command to be executed at this position. See Figure 162-7.
 - a) Press .
 - b) Press , , for 0.75 inches.
 - c) Press to retain 0.75 inches.

```
0 EXIT
1 PROGRAM FINISHED
2 NEXT STEP
PRESS NUMBER > 1
```

Figure 162-1

```
0 EXIT          3 CANCEL PROGRAM
1 SAVE PROGRAM  4 RUN THEN DELETE
2 SAVE PROGRAM AND RUN
PRESS NUMBER > 1
```

Figure 162-2

```
STORED PROGRAMS 1
PRESS NUMBER FROM 1 TO 17 TO SAVE.
ENTER PROGRAM NUMBER > 2
```

Figure 162-3

```
PROGRAM 2 SAVED
PRESS ANY KEY >
```

Figure 162-4

```
STEP 1 PROGRAM BY: POSITION
ENTER DEGREES ( 90.0) > 180
```

Figure 162-5

```
STEP 1 AT: 180.0 DEGREES,
ENTER COMMANDS, FINISHED..PRESS ENTER
```

Figure 162-6

```
STEP 1 AT: 180.0 DEGREES, DEPTH 0.75,
ENTER COMMANDS, FINISHED..PRESS ENTER
```

Figure 162-7

Scheduled Irrigation Cycles

Example 1. Time Delay with Run Program Command (continued)

5. Finish STEP 1 by pressing .
6. Press for NEXT STEP. See Figure 163-1.

Program STEP 2 - Example 1 - Program Three

7. To program the position, press for POSITION. See Figures 163-2 and 163-3.
 - a) Press for 0 degrees.
 - b) Press to retain 0 degrees.
8. Enter the command to be executed at this position. See Figure 163-4.
 - a) Press .
9. Finish STEP 2 by pressing .

Finish Programming

10. Finish program 3 by pressing for PROGRAM FINISHED. See Figure 163-5.
11. Press SAVE PROGRAM. See Figures 163-6, 163-7, and 163-8.
12. Press to select program number 3.
13. Press to save the program.

```
0 EXIT
1 PROGRAM FINISHED
2 NEXT STEP
PRESS NUMBER > 2
```

Figure 163-1

```
STEP 2 PROGRAM BY: POSITION

ENTER DEGREES ( 90.0) > 0
```

Figure 163-2

```
STEP 2 AT: 0.0 DEGREES,

ENTER COMMANDS, FINISHED..PRESS ENTER
```

Figure 163-3

```
STEP 2 AT: 0.0 DEGREES, STOP,

ENTER COMMANDS, FINISHED..PRESS ENTER
```

Figure 163-4

```
0 EXIT
1 PROGRAM FINISHED
2 NEXT STEP
PRESS NUMBER > 1
```

Figure 163-5

```
0 EXIT          3 CANCEL PROGRAM
1 SAVE PROGRAM  4 RUN THEN DELETE
2 SAVE PROGRAM AND RUN
PRESS NUMBER > 1
```

Figure 163-6

```
STORED PROGRAMS 1,2,

PRESS NUMBER FROM 1 TO 17 TO SAVE.
ENTER PROGRAM NUMBER > 3
```

Figure 163-7

```
PROGRAM 3 SAVED

PRESS ANY KEY >
```

Figure 163-8

Step Program Examples

START\$ Program Examples

To use the power restart feature, a START\$ program must be written and Auto Restart must be ON. Without a START\$ program, power restart will not operate correctly even though Auto Restart is ON. Refer to Example 1 - Delayed Start, and Example 2 - Immediate Start.

Example 1. Delayed Start

In this power restart example, the machine is started three minutes or 180 seconds after regaining power. Use a delayed power restart to reduce the possibility of damage to an electric pump if power is lost and regained in a short period of time. The time delay for safe restart of your pump/machine may be different. When the machine starts, the DIRECTION, PERCENT, DEPTH and WATER ON or WATER OFF settings remain the same as when the machine was last shut down. That is, unless the CYCLE\$ program or Daily OPS, along with a STEP program, commands other conditions.

Start Programming

To program Example 1, follow these steps.

1. To open the START\$ program write screen, press , . See Figure 164-1.
2. Press for START\$.
3. Press for WRITE.

```
START$,  
0 EXIT    2 WRITE  
1 REVIEW  3 EXECUTE  
PRESS NUMBER >
```

Figure 164-1

Program STEP 1 - Example 1

When WRITE is selected, the program screen automatically starts with Program By Delay.

4. Press for seconds. See Figures 164-2.
5. Press , , for 180 seconds. See Figure 164-3.
6. Press to retain 180 seconds. See Figure 164-4.
7. Press to enter it as the command to be executed after the delay. See Figure 164-5.

```
STEP 1 PROGRAM BY: DELAY  
  
DELAY 0..SECONDS 1..MINUTES > 0
```

Figure 164-2

```
STEP 1 PROGRAM BY: DELAY  
  
ENTER DELAY IN SECONDS > 180
```

Figure 164-3

```
STEP 1 AT: 180 SECONDS DELAY,  
  
ENTER COMMANDS, FINISHED..PRESS ENTER
```

Figure 164-4

```
STEP 1 AT: 180 SECONDS DELAY, START,  
  
ENTER COMMANDS, FINISHED..PRESS ENTER
```

Figure 164-5

NOTE: The START\$ program MUST contain the START command.

8. Finish STEP 1 by pressing . See Figure 164-5.

Finish Programming

9. Finish the START\$ program by pressing for PROGRAM FINISHED. See Figure 164-6.

The START\$ program is saved.

```
0 EXIT  
1 PROGRAM FINISHED  
2 NEXT STEP  
PRESS NUMBER > 1
```

Figure 164-6

START\$ Program Examples

Example 2. Immediate Start

In this power restart example, after a power failure occurs and power is regained, the machine is started immediately after the control panel's built in 10 second delay.

NOTE: Continue to use the delay time recommended by the manufacturer of your pumping system.





When the machine starts, the DIRECTION, PERCENT, DEPTH and WATER ON or WATER OFF remains the same as when the machine was last shut down. That is, unless the CYCLE\$ program or Daily OPS, along with a step program, commands other conditions.

CAUTION

• A DELAYED START IS RECOMMENDED TO REDUCE THE POSSIBILITY OF DAMAGE TO AN ELECTRIC PUMP IF POWER IS LOST AND REGAINED IN A SHORT PERIOD OF TIME.

Start Programming

To program Example 2, follow these steps.





- To open the START\$ program write screen, press , . See Figure 165-1.
- Press  for START\$.
- Press  for WRITE.

```
START$,
0 EXIT      2 WRITE
1 REVIEW   3 EXECUTE
PRESS NUMBER >
```

Figure 165-1

Program STEP 1 - Example 2

When WRITE is selected, the program screen automatically starts with Program By Delay.

- Press  for seconds. See Figures 165-2.
- Press  for 0 seconds. See Figure 165-3.
- Press  to retain 0 seconds. See Figure 165-4.
- Press  to enter it as the command to be executed immediately after the 10 second delay. See Figure 165-5.

```
STEP 1 PROGRAM BY: DELAY

DELAY 0..SECONDS 1..MINUTES > 0
```

Figure 165-2

```
STEP 1 PROGRAM BY: DELAY

ENTER DELAY IN SECONDS > 0
```

Figure 165-3

```
STEP 1 AT:      0 SECONDS DELAY,

ENTER COMMANDS, FINISHED..PRESS ENTER
```

Figure 165-4

NOTE: The START\$ program MUST contain the START command.

- Finish STEP 1 by pressing . See Figure 165-5.

```
STEP 1 AT:      0 SECONDS DELAY, START,

ENTER COMMANDS, FINISHED..PRESS ENTER
```

Figure 165-5

Finish Programming

- Finish the START\$ program by pressing  for PROGRAM FINISHED. See Figure 165-6.

The START\$ program is saved.

```
0 EXIT
1 PROGRAM FINISHED
2 NEXT STEP
PRESS NUMBER > 1
```

Figure 165-6

Step Program Examples

STOP\$ Program Example

Example 1. Immediate Stop



The STOP\$ program is used by daily OPS and the CYCLE\$ program to stop the machine. It is not necessary to write the STOP\$ program unless the user wants the machine to do something in addition to the stop command. The STOP\$ program, by default, stops the machine and pump (if wired to do so) unless programmed to do otherwise. The STOP command is not required to be in the STOP\$ program.

WARNING

•TO REDUCE THE POSSIBILITY OF SEVERE INJURY, DEATH AND/OR MAJOR EQUIPMENT OR PROPERTY DAMAGE, NEVER USE THE START COMMAND IN THE STOP\$ PROGRAM.

Start Programming

To write the STOP\$ program for Example 1, follow these steps.

1. To open the STOP\$ program write screen, press , . See Figure 166-1.

2. Press  for STOP\$.

3. Press  for WRITE.

4. Press  as the command to be executed. See Figure 166-2.

NOTE: The STOP command is not required to be in the STOP\$ program.

5. Finish STEP 1 by pressing . See Figure 166-3.

Finish Programming

6. Finish STEP 1 by pressing . See Figure 166-4.

```
STOP$,  
0 EXIT      2 WRITE  
1 REVIEW   3 EXECUTE  
PRESS NUMBER >
```

Figure 166-1

```
WRITE STOP$  
  
ENTER COMMANDS, FINISHED..PRESS ENTER
```

Figure 166-2

```
WRITE STOP$, STOP,  
  
ENTER COMMANDS, FINISHED..PRESS ENTER
```

Figure 166-3

```
0 EXIT  
1 PROGRAM FINISHED  
2 NEXT STEP  
PRESS NUMBER > 1
```

Figure 166-4

CYCLE\$ Program Examples - Repeating Cycles

Example 1. Using CYCLE\$ Program

In this example, the START\$, STOP\$, and CYCLE\$ programs is used to start the machine, complete two identical irrigation cycles, and stop the machine at 0°. See Figure 167-1.

Expected Conditions:

- Delayed START\$ program is written.
- STOP\$ program is written.
- Machine OFF at 0°.
- SIS position set for 0°.
- SIS is OFF.

Program Machine By:

- CYCLE\$ program.
- Position: At 0°, FORWARD, Depth 1.00".
- Position: At 180°, Depth 0.50".

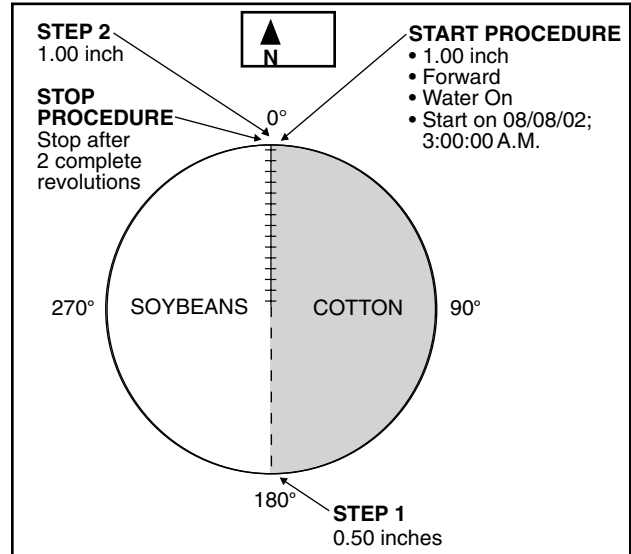

Figure 167-1

NOTE

- The stop-in-slot is used as a counter by the computer to signal when a cycle has been completed. During each cycle, the machine MUST pass the stop-in-slot position in order to execute the CYCLE\$ program again.

Start Programming

To write the CYCLE\$ program for Example 1, follow these steps.

1. To open the CYCLE\$ program Write screen, press **OPTIONS**, **8**. See Figure 167-2.
2. Press **5** for CYCLE\$.
3. Press **2** for WRITE.

```
CYCLE$,
0 EXIT      2 WRITE
1 REVIEW   3 EXECUTE
PRESS NUMBER
```

Figure 167-2

Program STEP 1 Example 1

4. Enter the commands to be executed. See Figure 167-3.
 - a) Press **FORWARD**.
 - b) Press **DEPTH**.
 - c) Press **1** for 1.00 inch.
 - d) Press **ENTER** to retain 1.00 inch.
5. Finish STEP 1 by pressing **ENTER**.
6. Press **2** for NEXT STEP. See Figure 167-4.

```
WRITE CYCLE$, FORWARD, DEPTH 1.00,
ENTER COMMANDS, FINISHED..PRESS ENTER
```

Figure 167-3

```
0 EXIT
1 PROGRAM FINISHED
2 NEXT STEP
PRESS NUMBER > 2
```

Figure 167-4

Step Program Examples

CYCLE\$ Program Examples - Repeating Cycles

Example 1. Using CYCLE\$ Program (continued)

Program STEP 2 - Example 1

7. To program the next position, press **2** for POSITION. See Figures 168-1 and 168-2.
 - a) Press **1**, **8**, **0** for 180 degrees.
 - b) Press **ENTER** to retain 180 degrees.
8. Enter the commands to be executed at the position. See Figure 168-3.
 - a) Press **DEPTH**.
 - b) Press **.**, **5** for 0.50 inch.
 - c) Press **ENTER** to retain 0.50 inch.
9. Finish STEP 2 by pressing **ENTER**.

```
STEP 2 PROGRAM BY: POSITION
ENTER DEGREES ( 90.0) > 180
```

Figure 168-1

```
STEP 2 AT: 180.0 DEGREES,
ENTER COMMANDS, FINISHED..PRESS ENTER
```

Figure 168-2

```
STEP 2 AT: 180.0 DEGREES, DEPTH 0.50,
ENTER COMMANDS, FINISHED..PRESS ENTER
```

Figure 168-3

Finish Programming

10. Finish the program by pressing **1** for PROGRAM FINISHED. See Figure 168-4.

```
0 EXIT
1 PROGRAM FINISHED
2 NEXT STEP
PRESS NUMBER > 1
```

Figure 168-4

Executing CYCLE\$

The CYCLE\$ program can be executed immediately (Option 1) from the OPTIONS / CYCLE\$ / EXECUTE screen, or the CYCLE\$ program can be executed by time (Option 2) through a step program.

Option 1 - Execute CYCLE\$ Immediately

To immediately execute the CYCLE\$ program, follow these steps.

1. To open the CYCLE\$ program Execute screen, press **OPTIONS**, **8**, **5**. See Figure 168-5.
2. Press **3** for EXECUTE.
3. Enter the number of cycles to complete. For this example use 2. See Figure 168-6.
 - a) Press **2** for 2 cycles.
 - b) Press **ENTER** to retain 2 cycles and execute the CYCLE\$ program.

```
CYCLE$,
0 EXIT 2 WRITE
1 REVIEW 3 EXECUTE
PRESS NUMBER
```

Figure 168-5

```
CYCLE$
0 EXIT 2 WRITE
1 REVIEW 3 EXECUTE
ENTER NUMBER OF CYCLES (0) > 2
```

Figure 168-6

NOTE: The machine starts immediately after pressing ENTER, and executes two complete cycles before stopping.

CYCLE\$ Program Examples - Repeating Cycles

Example 1. Using CYCLE\$ Program (continued)

Option 2 - Execute CYCLE\$ By Time

To execute the CYCLE\$ program due to a condition, follow these steps.

1. Press **PROGRAM**, **1** for STEP PROGRAMS.
2. Press **2** for CREATE NEW.
3. To program the start time, press **1** for TIME.
4. Press **0** for DATE/TIME.
 - a) Enter the date **0**, **8**, **0**, **8**, **0**, **2** for August 8, 2002 and press **ENTER**. See Figure 169-1.
 - b) Enter the time **0**, **3**, **0**, **0**, **0**, **0** for 3:00 AM and press **ENTER**. See Figures 169-2 and 169-3.
5. Enter the commands to be executed at that time. See Figure 169-4.
 - a) Press **OPTIONS**, **8**.
 - b) Press **5** for CYCLE\$.
 - c) Press **3** for EXECUTE
 - d) Press **2** for two cycles.
 - e) Press **ENTER** to retain two cycles.

Finish Programming

6. Finish the program by pressing **1** for PROGRAM FINISHED. See Figure 169-5.
7. Select one of the following. See Figures 169-6, 169-7, and 169-8.
 - Press **1** for SAVE PROGRAM.
 - (a) Select program number 1-17.
 - (b) Press **ENTER** to save the program.
 - Press **2** for SAVE PROGRAM AND RUN.
 - (c) Select program number 1-17.
 - (d) Press **ENTER** to save and run the program.
 - Press **3** for CANCEL PROGRAM to cancel the program.
 - Press **4** for RUN THEN DELETE to run the program once and then delete it.

```
STEP 1 PROGRAM BY: TIME
ENTER DATE (00/00/00) > 08/08/02
```

Figure 169-1

```
STEP 1 PROGRAM BY: TIME
ENTER TIME (00:00) > 03:00:00
```

Figure 169-2

```
STEP 1 AT: 08/08/02 03:00:00,
ENTER COMMANDS, FINISHED..PRESS ENTER
```

Figure 169-3

```
STEP 1 AT: 08/08/02 03:00:00,
SET CYCLE 2,
ENTER COMMANDS, FINISHED..PRESS ENTER
```

Figure 169-4

```
0 EXIT
1 PROGRAM FINISHED
2 NEXT STEP
PRESS NUMBER > 1
```

Figure 169-5

```
0 EXIT          3 CANCEL PROGRAM
1 SAVE PROGRAM  4 RUN THEN DELETE
2 SAVE PROGRAM AND RUN
PRESS NUMBER >
```

Figure 169-6

```
STORED PROGRAMS
PRESS NUMBER FROM 1 TO 17 TO SAVE.
ENTER PROGRAM NUMBER >
```

Figure 169-7

```
PROGRAM X SAVED
PRESS ANY KEY >
```

Figure 169-8

Step Program Examples

Daily OPS Examples - Scheduled Irrigation Hours

Example 1. Seven Days a Week

This example requires that DAILY OPS be active every day of the week. With this example, when the machine is running, the machine DIRECTION, PERCENT/DEPTH and WATER ON or WATER OFF settings remains the same as when the machine was last shut down.

Expected Conditions:

- Delayed START\$ program is written.
- Desired STOP\$ program is written.
- Machine is stopped at SIS position.

Program Machine To:

- STOP at 10:00 AM and START at 6:00 PM seven days a week.

The machine operates in the following way depending on mode.

Daily Operations Mode																																																																																
Sun	▶	Run	▶	Stopped - Run NOT Allowed	▶	Run	▶	Mon	▶	Run	▶	Stopped - Run NOT Allowed	▶	Run	▶	Tue	▶	Run	▶	Stopped - Run NOT Allowed	▶	Run	▶	Wed	▶	Run	▶	Stopped - Run NOT Allowed	▶	Run	▶	Thu	▶	Run	▶	Stopped - Run NOT Allowed	▶	Run	▶	Fri	▶	Run	▶	Stopped - Run NOT Allowed	▶	Run	▶	Sat	▶	Run	▶	Stopped - Run NOT Allowed	▶	Run	▶	HOURS	1	2	3	4	5	6	7	8	9	10	11	12	13	14	15	16	17	18	19	20	21	22	23	24
HOURS	1	2	3	4	5	6	7	8	9	10	11	12	13	14	15	16	17	18	19	20	21	22	23	24																																																								

Load Management Mode																																																																																
Sun	▶	Run	▶	Stopped - Run IS Allowed	▶	Run	▶	Mon	▶	Run	▶	Stopped - Run IS Allowed	▶	Run	▶	Tue	▶	Run	▶	Stopped - Run IS Allowed	▶	Run	▶	Wed	▶	Run	▶	Stopped - Run IS Allowed	▶	Run	▶	Thu	▶	Run	▶	Stopped - Run IS Allowed	▶	Run	▶	Fri	▶	Run	▶	Stopped - Run IS Allowed	▶	Run	▶	Sat	▶	Run	▶	Stopped - Run IS Allowed	▶	Run	▶	HOURS	1	2	3	4	5	6	7	8	9	10	11	12	13	14	15	16	17	18	19	20	21	22	23	24
HOURS	1	2	3	4	5	6	7	8	9	10	11	12	13	14	15	16	17	18	19	20	21	22	23	24																																																								

To program Example 1, follow these steps.

1. Press **SYSTEM**, **1**, **8**, **7**, **1** to display the Daily On/Off screen. See Figure 170-1.
2. Press **1** for DAILY OPS ON.
3. Press **1** to select and activate the Daily Operations mode. See Figure 170-2.
or
4. Press **2**, **1** to select and activate the Load Management mode. See Figures 170-2 and 170-3.
5. Press **2** for DAILY START/STOP to set the Daily OPS start and stop times.
 - a) Enter the start time **1**, **8**, **0**, **0**, **0**, **0** for 6:00 PM, and press **ENTER**. See Figure 170-4.
 - b) Enter the stop time **1**, **0**, **0**, **0**, **0**, **0** for 10:00 AM, and press **ENTER**. See Figure 170-5.
6. Select the day(s) of the week that Daily OPS will be active. Select every day of the week by pressing **1**, **2**, **3**, **4**, **5**, **6**, **7**, followed by **ENTER**. See Figure 170-6.

```
0 EXIT                3 CYCLE ON/OFF
1 DAILY ON/OFF       4 CYCLE INTERVAL
2 DAILY START/STOP  5 CYCLE START TIME
DAILY OPS (OFF) 1..ON 0..OFF >
```

Figure 170-1

```
0 EXIT                3 CYCLE ON/OFF
1 DAILY ON/OFF       4 CYCLE INTERVAL
2 DAILY START/STOP  5 CYCLE START TIME
MODE (1) 1..DAILY OPS 2..LOAD MNG. >
```

Figure 170-2

```
0 EXIT                3 CYCLE ON/OFF
1 DAILY ON/OFF       4 CYCLE INTERVAL
2 DAILY START/STOP  5 CYCLE START TIME
ACTIVATE (0) 1..YES 0..NO >
```

Figure 170-3

```
0 EXIT                3 CYCLE ON/OFF
1 DAILY ON/OFF       4 CYCLE INTERVAL
2 DAILY START/STOP  5 CYCLE START TIME
ENTER TIME TO START (00:00) > 18:00:00
```

Figure 170-4

```
0 EXIT                3 CYCLE ON/OFF
1 DAILY ON/OFF       4 CYCLE INTERVAL
2 DAILY START/STOP  5 CYCLE START TIME
ENTER TIME TO STOP (00:00) > 10:00:00
```

Figure 170-5

```
0 EXIT    3 TUESDAY    6 FRIDAY
1 SUNDAY  4 WEDNESDAY 7 SATURDAY
2 MONDAY  5 THURSDAY
ENTER DAYS (1,2,) > 1,2,3,4,5,6,7,
```

Figure 170-6

Step Program Examples

Daily OPS Examples - Scheduled Irrigation Hours

Example 2. Selected Days with Stop before Start

This example requires that DAILY OPS option be active only on Monday through Thursday. With this example, when the machine is running, the machine DIRECTION, PERCENT/DEPTH and WATER ON or WATER OFF settings remains the same as when the machine was last shut down.

Expected Conditions:

- Delayed START\$ program is written.
- Desired STOP\$ program is written.
- Machine is stopped at SIS position.

Program Machine To:

- STOP at 9:00 AM and START at 7:00 PM on Monday through Friday.

The machine operates in the following way depending on mode.

Daily Operations Mode	
Sun	Stopped - Run NOT Allowed
Mon	Stopped - Run NOT Allowed Run ▶
Tue	▶ Run Stopped - Run NOT Allowed Run ▶
Wed	▶ Run Stopped - Run NOT Allowed Run ▶
Thu	▶ Run Stopped - Run NOT Allowed Run ▶
Fri	▶ Run Stopped - Run NOT Allowed Run ▶
Sat	▶ Run Stopped - Run NOT Allowed Run ▶
HOURS	1 2 3 4 5 6 7 8 9 10 11 12 13 14 15 16 17 18 19 20 21 22 23 24

Load Management Mode			
Sun	Run	Run	Run
Mon	▶ Run Stopped - Run IS Allowed Run ▶		
Tue	▶ Run Stopped - Run IS Allowed Run ▶		
Wed	▶ Run Stopped - Run IS Allowed Run ▶		
Thu	▶ Run Stopped - Run IS Allowed Run ▶		
Fri	▶ Run Stopped - Run IS Allowed Run ▶		
Sat	▶ Run Run	▶ Run	▶ Run
HOURS	1 2 3 4 5 6 7 8 9 10 11 12 13 14 15 16 17 18 19 20 21 22 23 24		

To program Example 2, follow these steps.

1. Press **SYSTEM**, **1**, **8**, **7**, **1** to display the Daily On/Off screen. See Figure 171-1.
2. Press **1** for DAILY OPS ON.
3. Press **1** to select and activate the Daily Operations mode. See Figure 171-2.
or
4. Press **2**, **1** to select and activate the Load Management mode. See Figures 171-2 and 171-3.
5. Press **2** for DAILY START/STOP to set the Daily OPS start and stop times.
 - a) Enter the start time **1**, **9**, **0**, **0**, **0**, **0** for 7:00 PM, and press **ENTER**. See Figure 171-4.
 - b) Enter the stop time **0**, **9**, **0**, **0**, **0**, **0** for 9:00 AM, and press **ENTER**. See Figure 171-5.
6. Select the day(s) of the week that Daily OPS will be active. Select every day of the week by pressing **2**, **3**, **4**, **5**, followed by **ENTER**. See Figure 171-6.

```
0 EXIT                3 CYCLE ON/OFF
1 DAILY ON/OFF       4 CYCLE INTERVAL
2 DAILY START/STOP   5 CYCLE START TIME
DAILY OPS (OFF) 1..ON 0..OFF >
```

Figure 171-1

```
0 EXIT                3 CYCLE ON/OFF
1 DAILY ON/OFF       4 CYCLE INTERVAL
2 DAILY START/STOP   5 CYCLE START TIME
MODE (1) 1..DAILY OPS 2..LOAD MNG. >
```

Figure 171-2

```
0 EXIT                3 CYCLE ON/OFF
1 DAILY ON/OFF       4 CYCLE INTERVAL
2 DAILY START/STOP   5 CYCLE START TIME
ACTIVATE (0) 1..YES 0..NO >
```

Figure 171-3

```
0 EXIT                3 CYCLE ON/OFF
1 DAILY ON/OFF       4 CYCLE INTERVAL
2 DAILY START/STOP   5 CYCLE START TIME
ENTER TIME TO START (00:00) > 19:00:00
```

Figure 171-4

```
0 EXIT                3 CYCLE ON/OFF
1 DAILY ON/OFF       4 CYCLE INTERVAL
2 DAILY START/STOP   5 CYCLE START TIME
ENTER TIME TO STOP (00:00) > 09:00:00
```

Figure 171-5

```
0 EXIT    3 TUESDAY    6 FRIDAY
1 SUNDAY  4 WEDNESDAY 7 SATURDAY
2 MONDAY  5 THURSDAY
ENTER DAYS (1, 2, ) > 2, 3, 4, 5,
```

Figure 171-6

Step Program Examples

Daily OPS Examples - Scheduled Irrigation Hours

Example 3. Selected Days with Start before Stop

This example requires that DAILY OPS be active only on Monday through Thursday. With this example, when the machine is running, the machine DIRECTION, PERCENT/DEPTH and WATER ON or WATER OFF remains the same as when the machine was last shut down.

Expected Conditions:

- Delayed START\$ program is written.
- Desired STOP\$ program is written.
- Machine is stopped at SIS position.

Program Machine To:

- START at 1:00 AM and STOP at 9:00 AM on Monday through Thursday.

The machine operates in the following way, depending on mode.

Daily Operations Mode	
Sun	Stopped - Run NOT Allowed
Mon	Run
Tue	Run
Wed	Run
Thu	Run
Fri	Stopped - Run NOT Allowed
Sat	Stopped - Run NOT Allowed
HOURS	1 2 3 4 5 6 7 8 9 10 11 12 13 14 15 16 17 18 19 20 21 22 23 24

Load Management Mode	
Sun	Stopped - Run IS Allowed
Mon	Run
Tue	Run
Wed	Run
Thu	Run
Fri	Stopped - Run IS Allowed
Sat	Stopped - Run IS Allowed
HOURS	1 2 3 4 5 6 7 8 9 10 11 12 13 14 15 16 17 18 19 20 21 22 23 24

To program Example 3, follow these steps.

1. Press **SYSTEM**, **1**, **8**, **7**, **1** to display the Daily On/Off screen. See Figure 172-1.
2. Press **1** for DAILY OPS ON.
3. Press **1** to select and activate the Daily Operations mode. See Figure 172-2.
or
4. Press **2**, **1** to select and activate the Load Management mode. See Figures 172-2 and 172-3.
5. Press **2** for DAILY START/STOP to set the Daily OPS start and stop times.
 - a) Enter the start time **0**, **1**, **0**, **0**, **0**, **0** for 1:00 AM, and press **ENTER**. See Figure 172-4.
 - b) Enter the stop time **0**, **9**, **0**, **0**, **0**, **0** for 9:00 AM, and press **ENTER**. See Figure 172-5.
6. Select the day(s) of the week that Daily OPS will be active. Select every day of the week by pressing **2**, **3**, **4**, **5**, followed by **ENTER**. See Figure 172-6.

```
0 EXIT                3 CYCLE ON/OFF
1 DAILY ON/OFF       4 CYCLE INTERVAL
2 DAILY START/STOP  5 CYCLE START TIME
DAILY OPS (OFF) 1..ON 0..OFF >
```

Figure 172-1

```
0 EXIT                3 CYCLE ON/OFF
1 DAILY ON/OFF       4 CYCLE INTERVAL
2 DAILY START/STOP  5 CYCLE START TIME
MODE (1) 1..DAILY OPS 2..LOAD MNG. >
```

Figure 172-2

```
0 EXIT                3 CYCLE ON/OFF
1 DAILY ON/OFF       4 CYCLE INTERVAL
2 DAILY START/STOP  5 CYCLE START TIME
ACTIVATE (0) 1..YES 0..NO >
```

Figure 172-3

```
0 EXIT                3 CYCLE ON/OFF
1 DAILY ON/OFF       4 CYCLE INTERVAL
2 DAILY START/STOP  5 CYCLE START TIME
ENTER TIME TO START (00:00) > 01:00:00
```

Figure 172-4

```
0 EXIT                3 CYCLE ON/OFF
1 DAILY ON/OFF       4 CYCLE INTERVAL
2 DAILY START/STOP  5 CYCLE START TIME
ENTER TIME TO STOP (00:00) > 09:00:00
```

Figure 172-5

```
0 EXIT                3 TUESDAY        6 FRIDAY
1 SUNDAY              4 WEDNESDAY    7 SATURDAY
2 MONDAY              5 THURSDAY
ENTER DAYS (1, 2, ) > 2, 3, 4, 5,
```

Figure 172-6

Daily OPS Examples - Scheduled Irrigation Cycles

Example 4. Daily OPS Cycle - Interval in Days

Daily OPS cycle allows the operator to run complete irrigation cycles at specified intervals in days. For example, the operator may want to irrigate every 3 days or 5 days. This feature uses the START\$, STOP\$, and CYCLE\$ programs. See Figure 173-1.

Expected Conditions:

- Delayed START\$ program is written.
- STOP\$ program is written.
- Machine off at 0°.
- Stop-In-Slot is set to 0°.
- Stop-In-Slot is OFF.

Program Machine To:

- Start on 08/08/02, at 10:00 AM
- Water On.
- FORWARD, Depth 1.00".
- Depth 0.50" at 180°.
- Execute one complete revolution every three days.

NOTE

•The stop-in-slot is used as a counter by the computer to signal when a cycle has been completed. During each cycle, the machine MUST pass the stop-in-slot position in order to execute the CYCLE\$ program again.

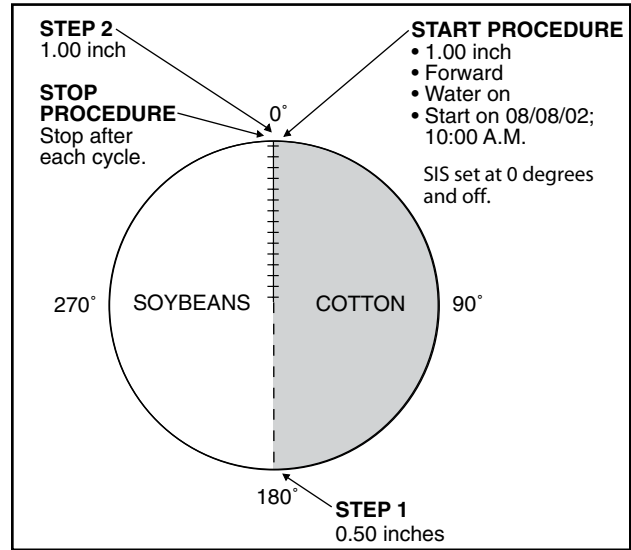

Figure 173-1

Setup Cycle Interval

To set up the Cycle Interval for Example 4, do the following.

1. Press **SYSTEM**, **1**, **8**, **7** to display the Daily OPS screen. See Figure 173-2.
2. Press **3** to display the Cycle On/Off screen. See Figure 173-3.
3. Press **1** to turn REPEAT CYCLE ON.
4. Press **4** to display the Cycle Interval screen. See Figure 173-4.
5. Press **3** to repeat the cycle every three days.
6. Press **ENTER** to retain three days.
7. Press **5** to display the Cycle Start Time screen. See Figure 173-5.
8. Press **1**, **0**, **0**, **0**, **0**, **0** for the 10:00 AM start time, and press **ENTER**.

```
0 EXIT                3 CYCLE ON/OFF
1 DAILY ON/OFF       4 CYCLE INTERVAL
2 DAILY START/STOP   5 CYCLE START TIME
PRESS NUMBER > 3
```

Figure 173-2

```
0 EXIT                3 CYCLE ON/OFF
1 DAILY ON/OFF       4 CYCLE INTERVAL
2 DAILY START/STOP   5 CYCLE START TIME
REPEAT CYCLE (OFF) 1..ON 0..OFF > 1
```

Figure 173-3

```
0 EXIT                3 CYCLE ON/OFF
1 DAILY ON/OFF       4 CYCLE INTERVAL
2 DAILY START/STOP   5 CYCLE START TIME
CYCLE INTERVAL ( 7 DAYS) > 3
```

Figure 173-4

```
0 EXIT                3 CYCLE ON/OFF
1 DAILY ON/OFF       4 CYCLE INTERVAL
2 DAILY START/STOP   5 CYCLE START TIME
ENTER TIME TO START (00:00) > 10:00:00
```

Figure 173-5

Step Program Examples

Daily OPS Examples - Scheduled Irrigation Cycles

Example 4. Daily OPS Cycle - Interval in Days (continued)

Write CYCLE\$ Program

To write the CYCLE\$ program for Example 4, follow these steps.

Program STEP 1 - Example 4

1. Press **OPTIONS**, **8**, **5**, **2** to display the CYCLE\$ Write screen. See Figure 174-1.
2. Enter the commands to be executed. See Figure 174-2.
 - a) Press **FORWARD**.
 - b) Press **DEPTH**.
 - c) Press **1** for 1.00 inch.
 - d) Press **ENTER** to retain 1.00 inch.
3. Finish STEP 1 by pressing **ENTER**. See Figure 174-3.
4. Press **2** for NEXT STEP.

```
WRITE CYCLE$  
  
ENTER COMMANDS, FINISHED..PRESS ENTER
```

Figure 174-1

```
WRITE CYCLE$, FORWARD, DEPTH 1.00,  
  
ENTER COMMANDS, FINISHED..PRESS ENTER
```

Figure 174-2

```
0 EXIT  
1 PROGRAM FINISHED  
2 NEXT STEP  
PRESS NUMBER > 2
```

Figure 174-3

Program STEP 2 - Example 4

5. To program the position, press **2** for POSITION. See Figure 174-4.
 - a) Press **1**, **8**, **0** for 180 degrees.
 - b) Press **ENTER** to retain 180 degrees.
6. Enter the command to be executed at this position. See Figures 174-5 and 174-6.
 - a) Press **DEPTH**.
 - b) Press **.**, **5** for 0.50 inches.
 - c) Press **ENTER** to retain 0.50 inches.
7. Finish STEP 2 by pressing **ENTER**.
8. Finish the program by pressing **1** for PROGRAM FINISHED. See Figure 174-7.

```
STEP 2 PROGRAM BY: POSITION  
  
ENTER DEGREES ( 90.0) > 180
```

Figure 174-4

```
STEP 2 AT: 180.0 DEGREES,  
  
ENTER COMMANDS, FINISHED..PRESS ENTER
```

Figure 174-5

```
STEP 2 AT: 180.0 DEGREES, DEPTH 0.50,  
  
ENTER COMMANDS, FINISHED..PRESS ENTER
```



Figure 174-6

```
0 EXIT  
1 PROGRAM FINISHED  
2 NEXT STEP  
PRESS NUMBER > 1
```

Figure 174-7

Program Screen

From the Program screen the user can choose to run, create, review/edit, store, and erase Sector programs.

1. Press  to view the Program screen. See Figure 175-1.
2. Press  for SECTOR PROGRAMS.

```
0 EXIT
1 STEP PROGRAMS
2 SECTOR PROGRAMS
PRESS NUMBER >
```

Figure 175-1

Sector Programs

Sector programming allows you to specify commands and options to be executed in unique regions, or sectors, of the field. When the machine enters the region, the Sector program overrides the normal machine operation with temporary settings. When the machine leaves the region, all settings are returned to the original settings.

Up to 20 Sector programs can be written for one field, with a maximum of 9 commands and options in each. The commands and options in a program are executed in the order in which they appear in the program.

Two Sector programs with overlapping regions, running in the same direction, cannot be run at the same time. If you attempt to run a stored program that overlaps with a running program, and runs in the same direction, the system displays a message telling you it cannot be loaded. See Figure 175-2. You can then modify the left or right angles of one or the other programs to allow them both to be run.

```
WARNING SECTOR PROGRAM 2 NOT LOADED
OVERLAP WITH RUNNING SECTOR PROGRAM 1

PRESS ANY KEY >
```

Figure 175-2

NOTE: Two Sector programs with overlapping regions, running in opposite directions, can be run at the same time.

When the program is completed, the program is deleted from the current memory, but remains in the stored memory.

Step Program Functions

- RUN STORED - Use to load stored sector programs in current memory for execution.
- CREATE NEW - Use to write new sector programs.
- REVIEW CURRENT - Use to review the current sector program.
- REVIEW STORED - Use to review, edit, and delete stored sector programs which can be recalled for execution
- ERASE - Use to erase stored sector programs from memory.

Available Options

- Auxiliary 1 ON/OFF
- Auxiliary 2 ON/OFF
- Modules 10-14 ON/OFF
- End Gun Enable/Disable
- Wide Boundary Enable/Disable
- Wide Boundary 2 Enable/Disable
- Wide Boundary 3 Enable/Disable
- Cruise Control with Hours Enable/Disable
- VRI Enable/Disable
- Percent of Percent
- Percent of Depth
- History Logging Event

Available Commands

- Percent
- Depth
- Stop
- Water ON
- Water OFF

Sector Programs

Using Run Stored

A stored Sector program can easily be run from the Pro2 control panel.

1. Press **PROGRAM**, **2** for SECTOR PROGRAMS.
1. Press **1** to select RUN STORED. See Figure 176-1.
2. Press the number of the program you want to run, and press **ENTER**. See Figure 176-2.

The screen displays a confirmation message. See Figure 176-3.

The program will begin running when the machine reaches the region specified.

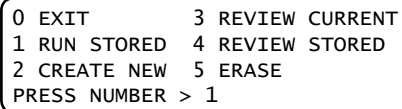

0 EXIT 3 REVIEW CURRENT
1 RUN STORED 4 REVIEW STORED
2 CREATE NEW 5 ERASE
PRESS NUMBER > 1

Figure 176-1

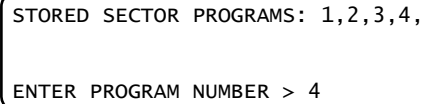

STORED SECTOR PROGRAMS: 1,2,3,4,
ENTER PROGRAM NUMBER > 4

Figure 176-2

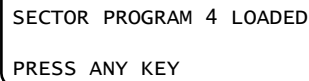

SECTOR PROGRAM 4 LOADED
PRESS ANY KEY

Figure 176-3

Sample Sector Program Design Form

The Sector Program Design Form is a useful tool when you are planning your Sector program. It provides you with the ability to describe the left and right angles, direction, and actions you want included in the program. Figure 177-1 below is an example of how the sectors could each be mapped out and described.

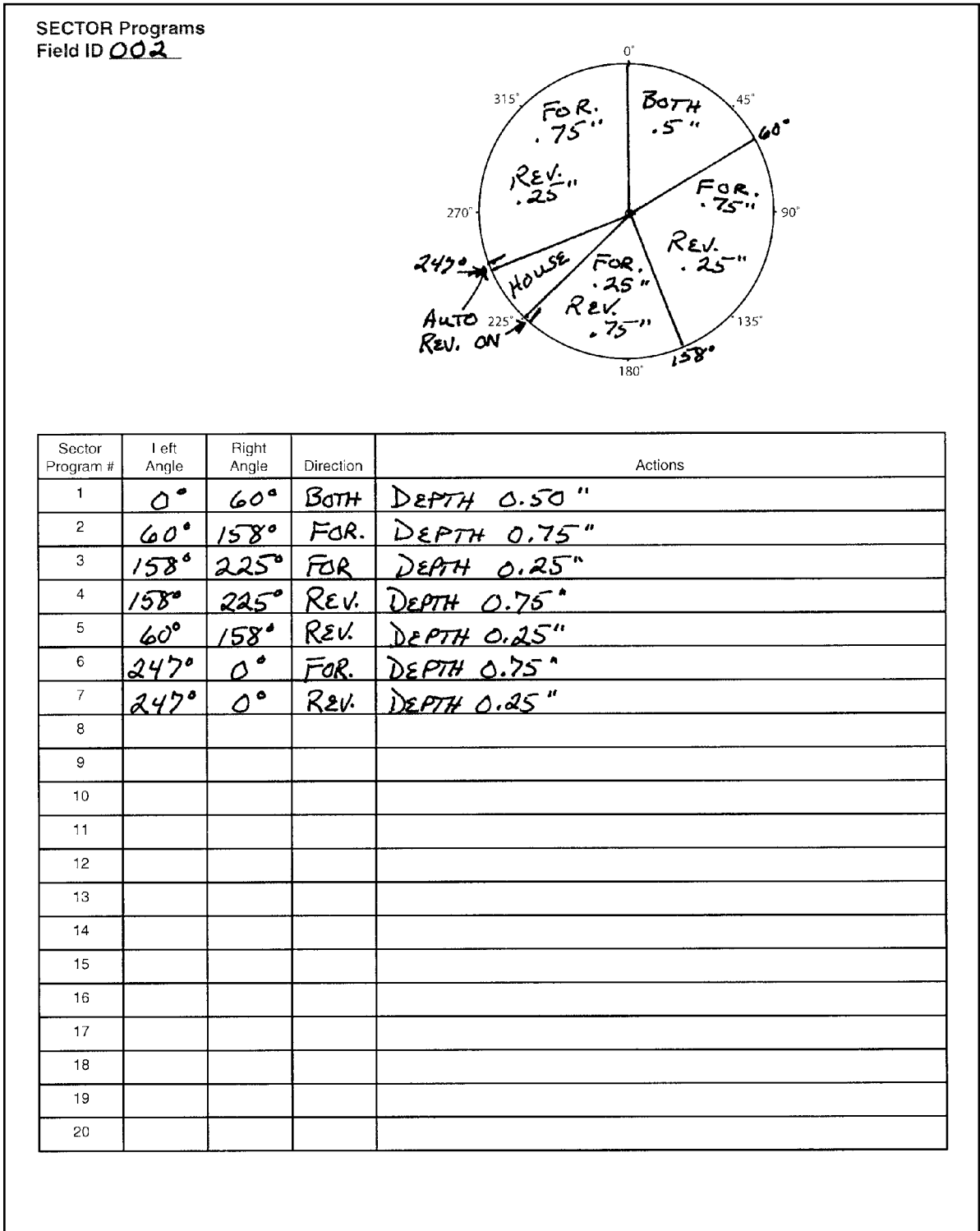

Figure 177-1

Sector Programs

Using Create New

To write a new Sector program, fill in a copy of the Sector Program Design Form with commands for each step. Refer to the sample Sector Program Design Form on the previous page. Blank forms are located in the Appendix. Using a completed design form, follow the steps below:

1. Press to display the Programs Selection screen. See Figure 178-1.
2. Press to select SECTOR PROGRAMS.
3. Press to select CREATE NEW. See Figure 178-2.
4. Enter the left angle of the new sector, and press . See Figure 178-3.
5. Enter the right angle of the new sector, and press . See Figure 178-4.
6. Select the direction in which the machine will be moving when this sector program begins. See Figure 178-5. The choices are:
 - BOTH - The program will begin when the machine is moving either forward or in reverse.
 - FOR - The program will begin only when the machine is moving forward.
 - REV - The program will begin only when the machine is moving in reverse.
7. Enter the commands and options for this sector. See Figures 178-6 and 178-7.
Example: , , , ,
8. When finished entering commands and options, press .

```
0 EXIT
1 STEP PROGRAMS
2 SECTOR PROGRAMS
PRESS NUMBER >
```

Figure 178-1

```
0 EXIT          3 REVIEW CURRENT
1 RUN STORED   4 REVIEW STORED
2 CREATE NEW   5 ERASE
PRESS NUMBER > 2
```

Figure 178-2

```
IF SECTOR, AND DIR: THEN COMMANDS

ENTER LEFT ANGLE (264.3) > 108
```

Figure 178-3

```
IF SECTOR, AND DIR: THEN COMMANDS
IF 108.0-

ENTER RIGHT ANGLE (310.0) > 150
```

Figure 178-4

```
IF SECTOR, AND DIR: THEN COMMANDS
IF 108.0-150.0,

DIR 0..BOTH 1..FOR 2..REV > 0
```

Figure 178-5

```
IF SECTOR, AND DIR: THEN COMMANDS
IF 108.0-150.0, BOTH: THEN

ENTER COMMANDS, FINISHED..PRESS ENTER
```

Figure 178-6

```
IF SECTOR, AND DIR: THEN COMMANDS
IF 108.0-150.0, BOTH: THEN
WATER ON, END-GUN ENABLED,

ENTER COMMANDS, FINISHED..PRESS ENTER
```

Figure 178-7

Using Create New (continued)

9. Finish the program by selecting one of the following. See Figures 179-1, 179-2, and 179-3.

- Press **1** for SAVE PROGRAM.
 - » Select program number 1-20.
 - » Press **ENTER** to save the program.
- Press **2** for SAVE PROGRAM AND RUN.
 - » Select program number 1-20.
 - » Press **ENTER** to save and run the program.
- Press **3** for CANCEL PROGRAM to cancel the program.
- Press **4** for RUN THEN DELETE to run the program once and then delete it.

```
0 EXIT          3 CANCEL PROGRAM
1 SAVE PROGRAM  4 RUN THEN DELETE
2 SAVE PROGRAM AND RUN
PRESS NUMBER > 1
```

Figure 179-1

```
STORED SECTOR PROGRAMS

PRESS NUMBER FROM 1 TO 20 TO SAVE
ENTER PROGRAM NUMBER > 2
```

Figure 179-2

```
SECTOR PROGRAM 2 SAVED

PRESS ANY KEY >
```

Figure 179-3

Using Review Current

To review current Sector program(s) that are running or will be executed as soon as their boundaries are reached, follow the steps below.

1. Press **PROGRAM**, **2**, **3** to display the Review Current screen. See Figure 179-4.
 2. Do one of the following. See Figure 179-5.
 - Press **ENTER** for next program.
 - » If another program is in current memory, it is displayed.
 - » If no other programs are in current memory, the End of Current Programs screen is displayed. See Figure 179-6.
 - Press **1** to delete the program from the current memory. Deleting a current program does not erase it from the stored program memory.
- or
- Press **ESC** to exit Review Current.

```
0 EXIT          3 REVIEW CURRENT
1 RUN STORED   4 REVIEW STORED
2 CREATE NEW   5 ERASE
PRESS NUMBER > 3
```

Figure 179-4

```
IF SECTOR, AND DIR: THEN COMMANDS
IF 108.0-150.0, BOTH: THEN
WATER ON, END-GUN ENABLED,
ENTER..NEXT 1..DELETE ESC..EXIT >
```

Figure 179-5

```
*** END OF CURRENT PROGRAMS ***

PRESS ANY KEY >
```

Figure 179-6

Sector Programs

Using Review (Edit) Stored

To review and/or edit Sector programs stored in memory, follow the steps below. All programs can be reviewed while the programs are running.

1. Press **PROGRAM**, **2**, **4** to display the Stored Programs screen. See Figures 180-1 and 180-2.
2. Enter the desired program number from the Stored Sector Programs list at the top of the screen.
3. Press **ENTER** to confirm the program number selection. The contents of the program are displayed. See Figure 180-3
4. You can now edit the program, if you want.

- If no changes are required, press **ENTER** to accept the program.
- If changes are required, do one or more of the following:

- » Press **←** (BS - Back Space) to move the flashing cursor back through the program to change a command or condition. The complete program can be deleted by pressing the back space key. When the cursor moves through all commands and conditions, the current screen will disappear.
- » Press **-** to erase the command or condition that the cursor is highlighting. Then, a new command or condition can be added.
- » When done, press **ENTER** to accept the program.

```
0 EXIT          3 REVIEW CURRENT
1 RUN STORED   4 REVIEW STORED
2 CREATE NEW   5 ERASE
PRESS NUMBER > 3
```

Figure 180-1

```
STORED SECTOR PROGRAMS 1,2,3,4,
ENTER PROGRAM NUMBER > 2
```

Figure 180-2

```
IF SECTOR, AND DIR: THEN COMMANDS
IF 108.0-150.0, BOTH: THEN
WATER ON, END-GUN ENABLED,
ENTER..ACCEPT BS..CURSOR -..DEL
```

Figure 180-3

Using Erase

To erase a Sector program that is stored in memory, follow the steps below:

1. Press **PROGRAM**, **2**, **5** to display the Stored Sector Programs screen. See Figure 180-4.
2. Enter the desired program number from the list at the top of the screen.
3. Press **ENTER** to confirm and erase the stored program number. See Figure 180-5.

NOTE: To delete any current programs, use the Review Current screen.

```
STORED SECTOR PROGRAMS 1,2,3,4,
ENTER PROGRAM NUMBER > 4
```

Figure 180-4

```
SECTOR PROGRAM 4 ERASED
PRESS ANY KEY >
```

Figure 180-5

Sector Program Examples

Designing Sector Programs

A sector program is a list of commands which need to occur in a specified order. The completed Sector Program Design Form example below illustrates how to use the form to outline the following example program. See Figure 181-1.

Example Sector Program and Design Form

Current Conditions:

- Machine ON at 0°.

Program Machine By:

- Position: At 45°, Water On, End-Gun Disabled, Depth 0.75 Inches
- Position: At 135°, Return to original settings
- Position: At 180°, Water Off, Percent 100
- Position: At 225°, Return to original settings

The program design form has been filled out to reflect the example program. Follow these steps as a guide when thinking about programs you want to write.

1. Make a sketch of the field and identify what you want the irrigation machine to do.
2. Determine what must happen first. This will be Sector Program #1.
3. Identify the left and right angles of the sector. (Ex: 45° and 135°)
4. Identify the direction in which the machine will be moving when the program is run (Forward, Reverse, or Both). (Ex: Both)
5. Identify what commands need to occur for Sector Program #1. (Ex: WATER ON, END-GUN DISABLED, 1.00 inch DEPTH)
6. Determine conditions and commands for all other steps.

NOTE: All steps are executed in sequential order.

If you complete the Sector Program Design Form, it makes entering the program easy.

Just follow each row across and enter the correct information.

A blank Sector Program Design Forms are provided in the Appendix.

SECTOR Programs
Field ID 002

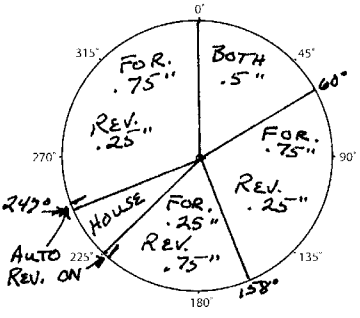

Sector Program #	Left Angle	Right Angle	Direction	Actions
1	0°	60°	BOTH	DEPTH 0.50"
2	60°	158°	FOR.	DEPTH 0.75"
3	158°	225°	FOR.	DEPTH 0.25"
4	158°	225°	REV.	DEPTH 0.75"
5	60°	158°	REV.	DEPTH 0.25"
6	247°	0°	FOR.	DEPTH 0.75"
7	247°	0°	REV.	DEPTH 0.25"
8				
9				
10				
11				
12				
13				
14				
15				
16				
17				
18				
19				
20				

Figure 181-1

Sector Program Examples

Using the STOP Command

In this program example, the machine is being programmed to stop in the event that it is not stopped by a barrier before crashing into a ditch. The grower will have to manually restart the machine to change its direction. There will be two sectors in this program to accommodate both forward and reverse directions. See Figure 182-1.

Normal System Operation:

- Machine: On at 0°
- Water: On
- Direction: Both
- Depth: 0.75 Inches

Program Sector:

- Left Angle: 189°
- Right Angle: 225°
- Direction: Both
- Command(s): Stop

Programming the Sector

To program first sector for STOP in the forward direction, follow these steps.

1. Press **PROGRAM**, **2** for SECTOR PROGRAMS.
2. Press **2** for CREATE NEW.
3. Press **1**, **8**, **9** for the left angle, and press **ENTER**.
See Figure 182-2.
4. Press **2**, **2**, **5** for the right angle and press **ENTER**.
See Figure 182-3.
5. Select **0** for the BOTH direction. See Figure 182-4.
6. Press **STOP** to enter the STOP command. See Figure 182-5.
7. Press **ENTER** for FINISHED. See Figure 182-6.

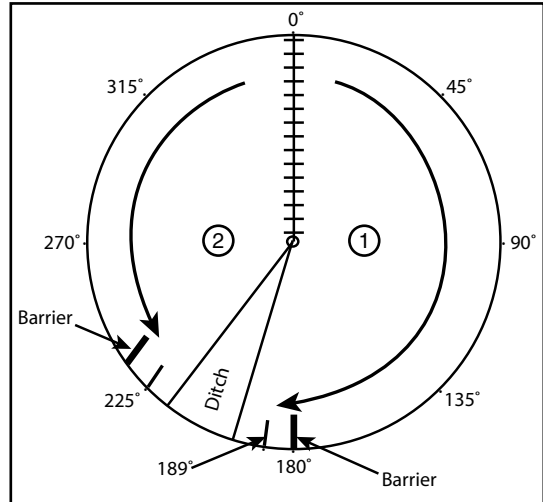

Figure 182-1 1. Sector 1 -Forward
2. Sector 2 - Reverse

```
IF SECTOR, AND DIR: THEN COMMANDS
ENTER LEFT ANGLE (000.0) > 189
```

Figure 182-2

```
IF SECTOR, AND DIR: THEN COMMANDS
IF 189.0-
ENTER RIGHT ANGLE (000.0) > 225
```

Figure 182-3

```
IF SECTOR, AND DIR: THEN COMMANDS
IF 189.0-225.0
DIR 0..BOTH 1..FOR 2..REV
```

Figure 182-4

```
IF SECTOR, AND DIR: THEN COMMANDS
IF 189.0-225.0, BOTH: THEN
ENTER COMMANDS, FINISHED..PRESS ENTER
```

Figure 182-5

```
IF SECTOR, AND DIR: THEN COMMANDS
IF 189.0-225.0, FOR: THEN
STOP,
ENTER COMMANDS, FINISHED..PRESS ENTER
```

Figure 182-6

Using the STOP Command

Programming the Sector (continued)

8. Press 1 for SAVE PROGRAM. See Figure 183-1.
9. Enter an available, non-stored program number. See Figure 183-2.

A message is displayed indicating that the Sector program has been saved. See Figure 183-3.

```
0 EXIT          3 CANCEL PROGRAM
1 SAVE PROGRAM  4 RUN THEN DELETE
2 SAVE PROGRAM AND RUN
PRESS NUMBER >
```

Figure 183-1

```
STORED SECTOR PROGRAMS: 1.2.3.4.
PRESS NUMBER FROM 1 TO 20 TO SAVE.
PRESS PROGRAM NUMBER >
```

Figure 183-2

```
SECTOR PROGRAM X SAVED
PRESS ANY KEY >
```

Figure 183-3

Sector Program Examples

Using the Depth and Percent Commands

In this programming example, the machine is programmed to override the normal system operation at a wet area of the field, resume normal operation, override the normal system operation at a dry area of the field, and resume normal operation. See Figure 184-1

Normal System Operation:

- Machine: On at 0°
- Water: On
- Direction: Forward
- Depth: 0.75 Inches

Program First Sector:

- Left Angle: 72°
- Right Angle: 90°
- Command(s): Water Off, Percent 100

Program Second Sector:

- Left Angle: 180°
- Right Angle: 225°
- Command(s): Depth 1.00 Inch

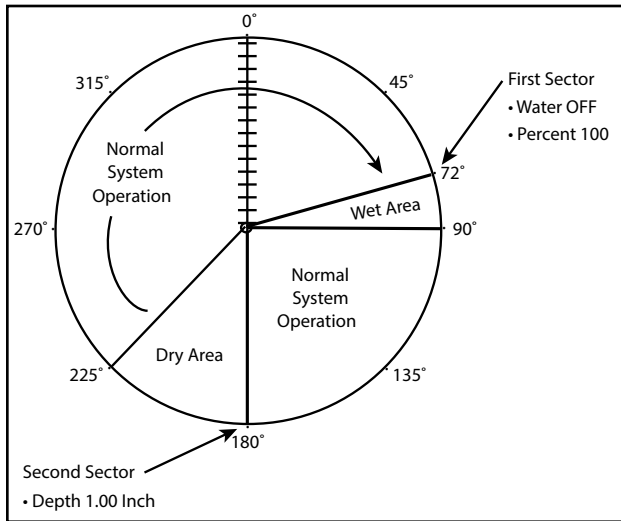

Figure 184-1

Programming the First Sector

To program the first sector for PERCENT, follow these steps.

1. Press **PROGRAM**, **2** for SECTOR PROGRAMS.
2. Press **2** for CREATE NEW.
3. Press **7**, **2** for the left angle and press **ENTER**. See Figure 184-2.
4. Press **9**, **0** for the right angle and press **ENTER**. See Figure 184-3.
5. Select **1** for the FORWARD direction. See Figure 184-4.
6. Press **WATER OFF** to enter the WATER OFF command.
7. Press **PERCENT**, and enter 100 to enter the PERCENT 100 command. See Figure 184-5.
8. Press **ENTER** for FINISHED. See Figure 184-6.

```
IF SECTOR, AND DIR: THEN COMMANDS
```

```
ENTER LEFT ANGLE (000.0) > 72
```

Figure 184-2

```
IF SECTOR, AND DIR: THEN COMMANDS
IF 72.0-
```

```
ENTER RIGHT ANGLE (000.0) > 90
```

Figure 184-3

```
IF SECTOR, AND DIR: THEN COMMANDS
IF 72.0- 90.0,
```

```
DIR 0..BOTH 1..FOR 2..REV
```

Figure 184-4

```
IF SECTOR, AND DIR: THEN COMMANDS
IF 72.0- 90.0, FOR: THEN
```

```
ENTER COMMANDS, FINISHED..PRESS ENTER
```

Figure 184-5

```
IF SECTOR, AND DIR: THEN COMMANDS
IF 72.0- 90.0, FOR: THEN
```

```
WATER OFF, PERCENT 100.0,
ENTER COMMANDS, FINISHED..PRESS ENTER
```

Figure 184-6

Using the Depth and Percent Commands Programming the Second Sector

To program the second sector for DEPTH, follow these steps.

1. Press for CREATE NEW.
2. Press , , for the left angle and press .
See Figure 185-1.
3. Press , , for the right angle and press .
. See Figure 185-2.
4. Select for the FORWARD direction. See Figure 185-3.
5. Press and enter 1.00 to enter the DEPTH command. See Figure 185-4.
6. Press for FINISHED.
7. Press for SAVE PROGRAM. See Figure 185-5.
8. Enter an available, non-stored program number. See Figure 185-6.

A message is displayed indicating that the Sector program has been saved. See Figure 185-7.

```
IF SECTOR, AND DIR: THEN COMMANDS
ENTER LEFT ANGLE (000.0) > 180
```

Figure 185-1

```
IF SECTOR, AND DIR: THEN COMMANDS
IF 180.0-
ENTER RIGHT ANGLE (000.0) > 225
```

Figure 185-2

```
IF SECTOR, AND DIR: THEN COMMANDS
IF 180.0-225,0
DIR 0..BOTH 1..FOR 2..REV
```

Figure 185-3

```
IF SECTOR, AND DIR: THEN COMMANDS
IF 180.0-225.0, FOR: THEN
DEPTH 1.00,
ENTER COMMANDS, FINISHED..PRESS ENTER
```

Figure 185-4

```
0 EXIT          3 CANCEL PROGRAM
1 SAVE PROGRAM  4 RUN THEN DELETE
2 SAVE PROGRAM AND RUN
PRESS NUMBER >
```

Figure 185-5

```
STORED SECTOR PROGRAMS: 1.2.3.4.
PRESS NUMBER FROM 1 TO 20 TO SAVE.
PRESS PROGRAM NUMBER >
```

Figure 185-6

```
SECTOR PROGRAM X SAVED
PRESS ANY KEY >
```

Figure 185-7

Sector Program Examples

Using the End Gun and VRI Enable/Disable Commands

In this programming example, the wind in the area has become high, and is expected to stay that way for several days. The grower has decided to turn off the end-gun. Additionally, a portion of the field that is normally wet, has dried out, and the grower wants to apply water in that area. See Figure 186-1.

Normal System Operation:

- Machine: On at 0°
- Water: On
- Direction: Forward
- Depth: 0.50
- End Gun: On
- VRI Zone: On

Program First Sector:

- Left Angle: 0°
- Right Angle: 359.9°
- Command(s): End Gun Disabled

Program Second Sector:

- Left Angle: 260°
- Right Angle: 270°
- Command(s): VRI Zone Disabled, Depth 1.00

Programming the First Sector

To program the first sector for WATER OFF, follow these steps.

1. Press **PROGRAM**, **2** for SECTOR PROGRAMS.
2. Press **2** for CREATE NEW.
3. Press **0** for the left angle and press **ENTER**. See Figure 186-2.
4. Press **3**, **5**, **9**, **.**, **9** for the right angle and press **ENTER**. See Figure 186-3.
5. Select **1** for the FORWARD direction. See Figure 186-4.
6. Press **OPTIONS**, **8**, **1**, **1**, **0** to enter the END-GUN DISABLED command. See Figures 186-5 and 186-6.
7. Press **ENTER** for FINISHED. See Figure 186-7.

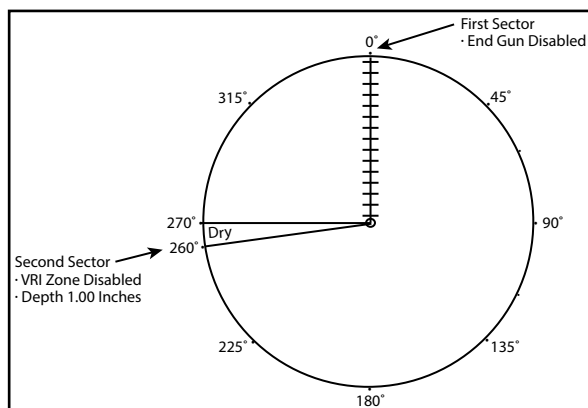

Figure 186-1

```
IF SECTOR, AND DIR: THEN COMMANDS
ENTER LEFT ANGLE (000.0) > 0
```

Figure 186-2

```
IF SECTOR, AND DIR: THEN COMMANDS
IF 0.0-
ENTER RIGHT ANGLE (000.0) > 359.9
```

Figure 186-3

```
IF SECTOR, AND DIR: THEN COMMANDS
IF 0.0-359.9,
DIR 0..BOTH 1..FOR 2..REV
```

Figure 186-4

```
IF SECTOR, AND DIR: THEN COMMANDS
IF 0.0-359.9, FOR: THEN
ENTER COMMANDS, FINISHED..PRESS ENTER
```

Figure 186-5

```
0 EXIT          PLC WIDE BND#2
1 END-GUN      4PLC WIDE BND#3
WIDE BND
END-GUN 1..ENABLE 0..DISABLE (1) > 0
```

Figure 186-6

```
IF SECTOR, AND DIR: THEN COMMANDS
IF 0.0-359.9, FOR: THEN
END-GUN-DISABLED,
ENTER COMMANDS, FINISHED..PRESS ENTER
```

Figure 186-7

Using the End Gun and VRI Enable/Disable Commands

Programming the First Sector (continued)

8. Press for SAVE PROGRAM. See Figure 187-1.
9. Enter an available, non-stored program number. See Figure 187-2.

A message is displayed indicating that the Sector program has been saved. See Figure 187-3.

Programming the Second Sector

To program the second sector for VRI ZONE DISABLE, follow these steps.

1. Press for CREATE NEW.
2. Press , , for the left angle and press . See Figure 187-4.
3. Press , , for the right angle and press . See Figure 187-5.
4. Select for the FORWARD direction. See Figure 187-6.
5. Press , , , to disable VRI.
6. Press enter 1.00 for the APPLICATION. See Figures 187-7 and 187-8.
7. Press for FINISHED. See Figure 187-8.

```
0 EXIT          3 CANCEL PROGRAM
1 SAVE PROGRAM 4 RUN THEN DELETE
2 SAVE PROGRAM AND RUN
PRESS NUMBER > 1
```

Figure 187-1

```
STORED SECTOR PROGRAMS: 1.2.3.4.
PRESS NUMBER FROM 1 TO 20 TO SAVE.
PRESS PROGRAM NUMBER >
```

Figure 187-2

```
SECTOR PROGRAM X SAVED
PRESS ANY KEY >
```

Figure 187-3

```
IF SECTOR, AND DIR: THEN COMMANDS
ENTER LEFT ANGLE (000.0) > 260
```

Figure 187-4

```
IF SECTOR, AND DIR: THEN COMMANDS
IF 260.0-
ENTER RIGHT ANGLE (000.0) > 270
```

Figure 187-5

```
IF SECTOR, AND DIR: THEN COMMANDS
IF 260.0-270.0,
DIR 0..BOTH 1..FOR 2..REV
```

Figure 187-6

```
IF SECTOR, AND DIR: THEN COMMANDS
IF 260.0-270.0, FOR: THEN
ENTER COMMANDS, FINISHED..PRESS ENTER
```

Figure 187-7

```
IF SECTOR, AND DIR: THEN COMMANDS
IF 260.0-270.0, FOR: THEN
VRI OFF, DEPTH 1.00,
ENTER COMMANDS, FINISHED..PRESS ENTER
```

Figure 187-8

Sector Program Examples

Using the End Gun and VRI Enable/Disable Commands

Programming the Second Sector (continued)

8. Press **1** for SAVE PROGRAM. See Figure 188-1.
9. Enter an available, non-stored program number. See Figure 188-2.

A message is displayed indicating that the Sector program has been saved. See Figure 188-3.

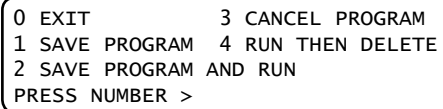

```
0 EXIT          3 CANCEL PROGRAM
1 SAVE PROGRAM  4 RUN THEN DELETE
2 SAVE PROGRAM AND RUN
PRESS NUMBER >
```

Figure 188-1

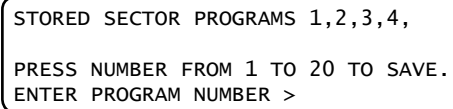

```
STORED SECTOR PROGRAMS 1,2,3,4,
PRESS NUMBER FROM 1 TO 20 TO SAVE.
ENTER PROGRAM NUMBER >
```

Figure 188-2

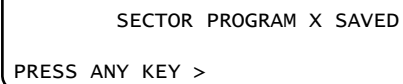

```
SECTOR PROGRAM X SAVED
PRESS ANY KEY >
```

Figure 188-3

Sector Program Examples

Using the Percent-of-Percent or Percent-of-Depth Command

In this program example, the region has recently experienced a lot of rain, and a low area of the soybean field has become wetter than usual. The machine is currently running at 60%, but you want to cut that in half for this area of the field. See Figure 189-1.

Normal System Operation:

- Machine: On at 0°
- Water: On
- Direction: Both
- Percent: 60

Program First Sector:

- Left Angle: 45°
- Right Angle: 80°
- Direction: Both
- Command: Percent of Depth = 50

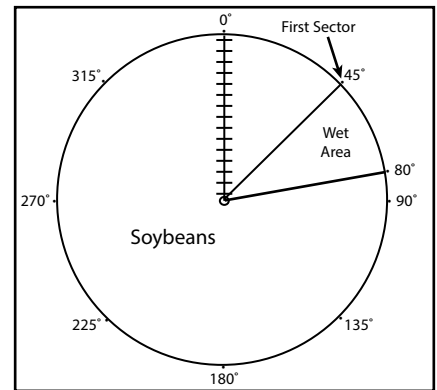

Figure 189-1

Programming the First Sector

To program the first sector for %-OF-%, follow these steps.

1. Press **PROGRAM**, **2** for SECTOR PROGRAMS.
2. Press **2** for CREATE NEW.
3. Press **4**, **5** for the left angle, and press **ENTER**. See Figure 189-2.
4. Press **8**, **0** for the right angle, and press **ENTER**. See Figure 189-3.
5. Press **0** for BOTH directions. See Figure 189-4.
6. Press **OPTIONS**, **8**, **2** for PERCENT. See Figures 189-5 and 189-6.

```
IF SECTOR, AND DIR: THEN COMMANDS
```

```
ENTER LEFT ANGLE (265.0) > 45
```

Figure 189-2

```
IF SECTOR, AND DIR: THEN COMMANDS
```

```
IF 45.0-
```

```
ENTER RIGHT ANGLE (265.0) > 80
```

Figure 189-3

```
IF SECTOR, AND DIR: THEN COMMANDS
```

```
IF 45.0- 80.0,
```

```
DIR 0..BOTH 1..FOR 2..REV > 0
```

Figure 189-4

```
IF SECTOR, AND DIR: THEN COMMANDS
```

```
IF 45.0- 80.0, BOTH: THEN
```

```
ENTER COMMANDS, FINISHED..PRESS ENTER
```

Figure 189-5

```
0 EXIT          3 START$      6 MODULE
```

```
1 END-GUNS     4 STOP$       7 VRI
```

```
2 PERCENT     5 CYCLE
```

```
PRESS NUMBER > 2
```

Figure 189-6

Sector Program Examples

Using the Percent-of-Percent or Percent-of-Depth Command

Programming the First Sector (continued)

7. Press for %-OF-DEPTH. See Figure 190-1.
8. Press , for 50 percent, and press . See Figure 190-2.
9. Press for FINISHED. See Figure 190-3.
10. Press for SAVE PROGRAM. See Figure 190-4.
11. Enter an available, non-stored program number. See Figure 190-5.

A message is displayed indicating that the Sector program has been saved. See Figure 190-6.

```
0 EXIT          3 START$      6 MODULE
1 END-GUNS     4 STOP$      7 VRI
2 PERCENT      5 CYCLE
PRESS 0..%-OF-% 1..%-OF-DEPTH >
```

Figure 190-1

```
0 EXIT          3 START$      6 MODULE
1 END-GUNS     4 STOP$      7 VRI
2 PERCENT      5 CYCLE
ENTER % OF DEPTH > 50
```

Figure 190-2

```
IF SECTOR, AND DIR: THEN COMMANDS
IF 45.0- 80.0, BOTH: THEN
50% OF DEPTH,
ENTER COMMANDS, FINISHED..PRESS ENTER
```

Figure 190-3

```
0 EXIT          3 CANCEL PROGRAM
1 SAVE PROGRAM  4 RUN THEN DELETE
2 SAVE PROGRAM AND RUN
PRESS NUMBER >
```

Figure 190-4

```
STORED SECTOR PROGRAMS 1,2,3,4,
PRESS NUMBER FROM 1 TO 20 TO SAVE.
ENTER PROGRAM NUMBER >
```

Figure 190-5

```
SECTOR PROGRAM X SAVED
PRESS ANY KEY >
```

Figure 190-6

Programming Design Forms

Design Forms

This appendix provides blank forms for your use when planning your Step and Sector programs. They provide you with the ability to describe the conditions, commands, and options you want included in the programs.

Make as many copies of these forms as you need. You may want to keep the completed design forms on file for future reference.

Step Programming Design Form

Use the circular drawing to map out the field, and the table to describe the conditions, commands, and options required in each step of the program. You can have up to 17 Step programs for each machine, with up to 9 steps in each.

NOTE: The commands in each step will be executed in the order in which they are entered.

Sector Programming Design Form

Use the circular drawing to map out the field, and the table to describe the commands and options required in each sector of the field. You can have up to 20 Sector programs for each machine, with up to 9 steps in each.

NOTE: The commands for each sector will be executed in the order in which they are entered.

Programming Design Forms

STEP Program Number _____
 Field ID _____

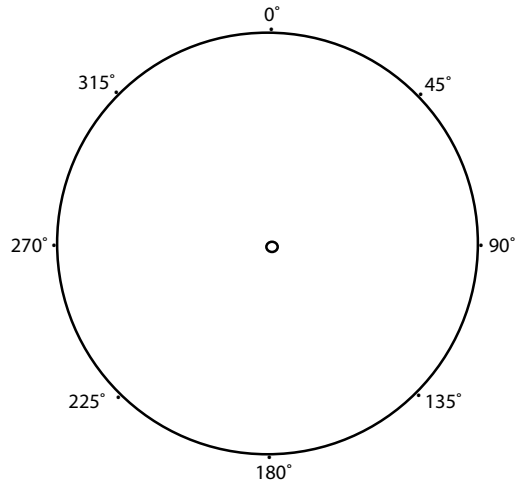

CONDITIONS	STEP 1	STEP 2	STEP 3	STEP 4	STEP 5	STEP 6	STEP 7	STEP 8	STEP 9
TIME / DATE									
TIME / DAY									
POSITION									
PRESSURE									
DELAY									
FOR / REV									
ANALOG									
MODULE									
PULSE									
COUNT									
WIND									
TEMPERATURE									
RAIN									
COMMAND KEYS									
WATER ON/OFF									
PERCENT									
DEPTH									
DIRECTION FWD/REV									
STOP-IN-SLOT ON/OFF									
START									
STOP									
OPTIONS									
AUX 1 ON / OFF									
AUX 2 ON / OFF									
START\$									
STOP\$									
CYCLE\$									
MODULE									
AUTO REVERSE									
AUTO RESTART									
AR / AS									
CRUISE CONTROL EN / DIS									
ENDGUNS									
WIDE BOUNDARY 1									
WIDE BOUNDARY PLC 2									
WIDE BOUNDARY PLC 3									
VRI ON / OFF									

Programming Design Forms

SECTOR Programs
Field ID _____

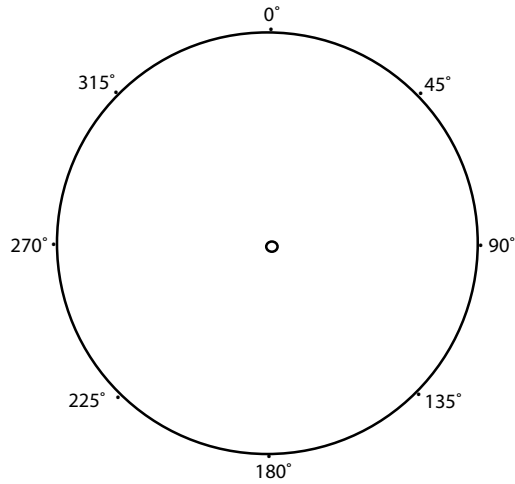

Sector Program #	Left Angle	Right Angle	Direction	Actions
1				
2				
3				
4				
5				
6				
7				
8				
9				
10				
11				
12				
13				
14				
15				
16				
17				
18				
19				
20				

Programming Design Forms
