



## **2 Wheel Linear Owner's Manual**

**0997618\_D**





# TABLE OF CONTENTS

<b>EC Declaration of Conformity</b> .....	<b>7</b>
<b>Declaration of Conformity</b> .....	<b>8</b>
<b>Electrical Safety Statement</b> .....	<b>9</b>
<b>About This Manual</b> .....	<b>9</b>
<b>Ancillary Equipment Warranty</b> .....	<b>9</b>
<b>Safety</b> .....	<b>10</b>
Recognize Safety Information .....	10
Safety Messages .....	10
Information Messages .....	10
Use Of Personal Protective Equipment.....	11
Conductive Materials And Equipment .....	11
Fall Protection.....	11
Minimum Working Clearance .....	12
Qualified Person.....	12
Overhead Power Lines .....	13
Minimal Lockout / Tagout Procedure .....	14
Sequence Of Lockout .....	14
Operate Safely.....	15
Safety Decals .....	19
2 Wheel Linear .....	22
End Feed Machine .....	22
Spans .....	23
Drive Towers.....	23
Hitch .....	23
Overhang.....	23
End Gun .....	23
Water Application .....	24
Span Safety Box.....	24
Span Cable.....	24
Intermediate Tower Boxes .....	24
Last Tower Box .....	24
Central Pulse Tower Box .....	25
Safety Circuit .....	26
Alignment .....	26
Guidance System.....	27
Below Ground Guidance (Option).....	27
Furrow Guidance (Option) .....	27
GPS Guidance (Option).....	27
Cart Mounted AR/AS Box (Option).....	28
Engine Generator (Option).....	28
Cart Mounted End Of Field And Hose Stop Switch.....	28
Electric Cord Drag (Option) .....	29
Auto Reverse/Auto Stop Box (Option) .....	29
Control Panel.....	30
Drive Unit Mounted End of Field .....	30
Stop/Auto Reverse (Option) .....	30

# TABLE OF CONTENTS

---

<b>Operation.....</b>	<b>32</b>
Machine Operation .....	32
Overwatering Timer.....	32
End of Field, Hose and Cord StopSwitch .....	33
Auto Reverse/Auto Stop (Option) .....	33
Stop Bracket.....	33
Tee Inlet (Swing Around) .....	34
Furrow Guidance Arms .....	34
Ditch Feed (Option) .....	34
Starting and Stopping the Machine .....	35
Starting the Machine.....	35
Emergency Stopping .....	35
Stopping Under Normal Conditions .....	35
Establishing Wheel Tracks .....	36
Wheel Tracks.....	36
Direction of Travel.....	36
Establishing Perpendicular Wheel Tracks .....	36
Establishing Parallel Wheel Tracks.....	37
Methods Of Operation .....	38
Method I.....	38
Method II.....	39
Method III.....	39
Method IV .....	40
Method V.....	40
Linear Water Application Data .....	41
Wheel Rotation Speeds .....	41
Percentage Timer Settings.....	41
Closed Delivery .....	42
Electric Cord Handling.....	42
Electric Cord Operation .....	42
Poly Hose.....	44
Moving Poly Hose .....	44
Cart Path.....	44
Hose Bumpers .....	44
Hose Inlets and Couplers .....	45
Hose and Cord Positioning .....	46
Guidelines .....	46
Standard Linear Manual Method.....	48
Standard Linear Auto Reverse .....	52
Swing Around Linear .....	55
Swing Around Linear (Continued).....	59
Pivoting Methods.....	59
Fixed Wheel .....	59
Pivoting Methods.....	60
Concrete Anchor .....	60
Classicplus Control Panel Pivoting Procedure.....	61
AutoPilot Control Panel Pivoting Procedure.....	62
Towing Option.....	63
Preparing The Drive Units For Towing .....	63
Fixed Tow Linkage.....	65
Steerable Tow Linkage .....	66
Towing The 2 Wheel Linear.....	67
Preparing The Drive Units For Operation.....	68

# TABLE OF CONTENTS

Open Delivery.....	70
Start Up - Engine Generator Electric Pump Applications .....	70
Hand Pump Primer .....	72
Start Up - Electric Cord / Motor Pump Applications.....	73
Open Delivery.....	74
Electric Cord Handling and Operation .....	74
Electric Cord Operation .....	74
Open Delivery.....	76
Electric Cord Handling and Operation .....	76
Electric Cord Positioning .....	76
Open Delivery.....	78
Swing Around Option.....	78
Swing Around Methods.....	78
Fixed Wheel .....	78
Concrete Anchor .....	79
Classicplus Control Panel Pivoting Procedure.....	80
AutoPilot Control Panel Pivoting Procedure.....	81
Open Delivery.....	82
Towing Option.....	82
Preparing The Drive Units For Towing .....	82
Steerable Tow Linkage .....	85
Towing The 2 Wheel Linear.....	86
Preparing The Drive Units For Operation.....	87
<b>Maintenance.....</b>	<b>89</b>
Safety .....	89
Disconnect All Power .....	89
Wheel Gearbox .....	90
Center Drive Gearmotors .....	91
Helical Gearmotor.....	91
Worm Gearmotor.....	91
Tire And Wheel.....	92
Towable Hub Lubrication.....	92
Wheel Lug Nut Torque .....	92
Tire Pressures .....	92
Centrifugal Pump Lubrication .....	93
Furrow .....	94
Furrow End of Field Shutdown .....	94
Cart Path .....	95
Barricade .....	95
Wheel Tracks .....	95
Engine/Generator.....	95
Span Safety Box Cable Tension Adjustment .....	96
Side Inlet Elbow Adjustment.....	97
Poly Hose Repair.....	98
Rigid Mender Installation .....	98
Flex Joint Hose Replacement .....	98
Bonding Ground Wire.....	98
Span Flushing Procedure .....	104
Span Flushing Procedure.....	106
Winterization.....	107
Off Season Storage of Hose.....	107
Off Season Storage of Electric Cord.....	107
Recommended Maintenance .....	108
Hardware Identification.....	111
Ancillary Equipment.....	111
Special Torque Applications .....	111

# TABLE OF CONTENTS

---

- Troubleshooting..... 113**
- Safety ..... 113
- In-Line Shut Down..... 114
- Tower Ahead Shut Down..... 115
- Tower Behind Shut Down ..... 116
- Operation..... 117

# EC DECLARATION OF CONFORMITY



We: **Valmont Industries, Inc.**  
**28800 Ida Street**  
**Valley, NE 68064**  
**+1 402.359.6312**  
**+1 402.359.6143 (Facsimile)**

Serial Number:

Purchase Order:

declare under our sole responsibility that the product,

## **Crop Irrigation System**

to which this documentation relates, is in conformity with the following documents:

**Machinery Directive 2006/42/EC**  
**Low Voltage Directive 2006/95/EC**  
**Electromagnetic Compatibility Directive 2004/108/EC**

The above-referenced equipment is in conformity with all safety-related clauses (Not all clauses reflecting commercial preference are met) of the following documents:

**EN 60204-1:2006 Safety of Machinery – Electrical Equipment of Machines**  
**EN 12100:2010 Safety of Machinery**  
**EN 909:1998+A1 Irrigation Machines**

Statement regarding **Pressure Equipment Directive 97/23/EC:**

The Crop Irrigation System is excluded from the scope of the Pressure Equipment Directive, by the language of Article 1, Sections 3.2, 3.6 & 3.10. This equipment is classified less than Category 1.

Statement regarding **RoHS Directive 2011/65/EC:**

The Crop Irrigation System is excluded from the scope of the RoHS Directive, by the language of Article 2, Section 4(e), being a "Large Scale Fixed Installation."

Person Authorized to Compile the Technical File in Europe:  
Relevant information will be transmitted via e-mail  
in response to a reasoned request by national authorities

Philipp Schmidt-Holzmann  
Valmont S.A.U.  
28840 Mejorada del Campo  
Madrid, ES 28840  
+34 91 679 4300

Ron Pollak  
Senior Electrical Engineer  
Valmont Industries, Inc.

Date of Issue: March 9, 2015  
Place of Issue: Valley, NE 68064

# ELECTRICAL SAFETY STATEMENT

---

## Installation Of The Valley Electric Irrigation Machine - European Union Only

Valmont Industries Inc. does not install a differential (ground fault) circuit breaker in the control panel of the Valley electric irrigation machine because the standards of protection vary according to country of destination. The distributor must provide and install a differential (ground fault) circuit breaker that meets the standards of the country where the Valley irrigation machine is installed.

In the European Union, differential circuit breaker protection is fixed at a maximum of 24 volts.

Good grounding of the Valley irrigation machine is required.

- If resistance to ground is lower than 80 ohms, a differential (ground fault) circuit breaker of 300 mA will meet requirements.
- If resistance to ground is between 80 and 800 ohms, a differential (ground fault) circuit breaker of 30 mA will meet requirements.

The power supply installation and inspection of equipment protection components or systems are the responsibility of the installer. Valmont Industries, Inc. is not responsible for the failure of equipment protection components or systems not of their manufacture.

Valley pivot irrigation machines receiving power from a generator must have a cable connected from the irrigation machine structure to a ground rod and another cable from the irrigation machine structure to the ground terminal on generator in order for the differential (ground fault) circuit breaker to work.

The linear irrigation machines equipped with a generator are not equipped with a ground rod but must have a cable connected from the linear irrigation machine structure to the ground terminal of the generator in order for the differential (ground fault) circuit breaker to work.

- The resistance between the irrigation machine and the generator must be substantially below 80 ohms.

## About This Manual

Information contained in this manual applies to Valley 2 Wheel Linear Irrigation Machines.

All information in this manual is based on information available at the time of printing. Valmont Industries Inc. reserves the right to make changes at any time without notice and without incurring any obligation. Specifications are applicable to equipment sold within the United States and may vary outside of the United States.

## Ancillary Equipment Warranty

The owner is responsible for warranty registration of all ancillary equipment such as engines, pumps and generators with its respective manufacturer.

## Recognize Safety Information

This irrigation equipment can be powered by high voltage, which can be extremely dangerous if used improperly. For maximum safety and optimum performance of the machine, all owner/operators and maintenance personnel must read and understand the owner/operator manual(s), all safety messages in this manual and safety signs/decals on the machine before operating this equipment.

Anyone assembling, operating, servicing or maintaining this machine must read and understand all operation, maintenance, troubleshooting, testing, installation, assembly instructions and all safety messages in this manual before operating the machine or beginning any maintenance, troubleshooting, testing, installation or assembly of components.

These instructions alert you to certain things you should do carefully; if you don't, you could hurt yourself or others, hurt the next person who operates the equipment, or damage the equipment.

## Safety Messages

Safety messages in this manual are preceded by the hazard symbol and one of three words: DANGER, WARNING or CAUTION. These messages alert you to potential hazards that could hurt you or others and or cause property damage.



This HAZARD SYMBOL is used to alert you to information about unsafe actions or situations, and may be followed by the word DANGER, WARNING or CAUTION.

### **DANGER**

The HAZARD SYMBOL used with the word DANGER describes immediate hazards that can result in severe personal injury or death.

### **WARNING**

The HAZARD SYMBOL used with the word WARNING describes unsafe actions or situations that can result in severe injury, death and/or major equipment or property damage.

### **CAUTION**

The HAZARD SYMBOL used with the word CAUTION describes unsafe actions or situations that can result in injury, and/or minor equipment or property damage.

## Information Messages

Important information messages in this manual are preceded by the word NOTE.

### **NOTE**

The word NOTE is used to alert you to information that describes procedures or tips to help you install, operate or maintain your equipment properly.

# SAFETY

---

## Use of Personal Protective Equipment

- People working in areas where there are potential electrical hazards must use, personal protective equipment that is appropriate for the specific parts of the body to be protected and for the work to be performed. Refer to U.S. Occupational Safety & Health Administration (OSHA) Regulations (Standards - 29 CFR) Safeguards for personnel protection. - 1910.335, or applicable national, state or local regulations, for additional information.
- Personal protective equipment must be maintained in a safe, reliable condition and periodically inspected or tested.
- Protective shields, protective barriers, or insulating materials must be used to protect each person from shock, burns, or other electrically-related injuries while that person is working near exposed energized parts which might be accidentally contacted or where dangerous electric heating or arcing might occur. When normally enclosed live parts are exposed for maintenance or repair, they must be guarded to protect unqualified persons from contact with the live parts.
- Safety signs and tags. Safety signs, safety symbols, or accident prevention tags must be used where necessary to warn people about electrical hazards which may endanger them.

## Conductive Materials and Equipment

Materials and equipment that can conduct electricity must be handled in a way that will prevent them from contacting energized power lines, exposed conductors or circuit parts.

- When handling long conductive objects (such as but not limited to truss rods, pipes, angles and ladders) in areas with energized power lines, exposed conductors or circuit parts, work practices (such as the use of insulation, guarding, and material handling techniques) must be used to minimize the hazard.
- Portable ladders must have non-conductive side rails.
- Do not wear conductive articles of jewelry and clothing (such as but not limited to watch bands, bracelets, rings, key chains, necklaces, metalized aprons, cloth with conductive thread, or metal headgear) that could come in contact with energized power lines, exposed conductors or circuit parts.

## Fall Protection

Identify potential fall hazards and determine if fall protection equipment is appropriate for the task, before beginning the work. Pay attention to hazards associated with routine and non-routine tasks. Inspect fall protection equipment (harnesses, lanyards) and devices (guardrails, tie-off points) before each use. Use fall protection equipment if required for the job. Be sure the fall protection equipment is right for the task, fits properly, and is in good condition. Refer to U.S. Occupational Safety & Health Administration (OSHA) Regulations Standards - 29 CFR 1926.500, 1926.501 and 1926.502, or applicable national, state or local regulations for more information.

- When using scaffolds, make sure there is proper access, full planking, stable footing, and guard railing.
- When using a boom lift, keep feet firmly on the platform of a boom lift, use fall protection equipment tied-off at all times to the guardrail or tie-off point.
- When using a ladder, make sure the ladder is non-conductive and the correct size for the task. Read the ladder user instructions and be sure the ladder is in good condition. Make sure ladder is set on stable footing and at the correct angle.



## Minimum Working Clearance

To reduce the risk of injury, all persons require adequate working clearance around the electrical panel or other electrical equipment. The table below identifies the minimum working clearance needed. Refer to U.S. Occupational Safety & Health Administration (OSHA) Regulations (Standards - 29 CFR) Safeguards for personnel protection. -1910.303(g)(1)(i), or any other applicable national, state or local regulations, for additional information.

MINIMUM WORKING CLEARANCE 0-600 VOLTS				
WIDTH OF WORKING CLEARANCE AREA	HEIGHT OF WORKING CLEARANCE AREA	★ MINIMUM WORKING CLEARANCE IN FRONT OF ELECTRICAL PANEL/EQUIPMENT		
		EXPOSED LIVE PARTS ON ONE SIDE OF WORK SPACE AND NO LIVE GROUNDED PARTS ON THE OTHER SIDE.	EXPOSED LIVE PARTS ON ONE SIDE OF WORK SPACE AND LIVE GROUNDED PARTS ON THE OTHER SIDE.	EXPOSED LIVE PARTS ON ONE SIDE OF WORK SPACE AND EXPOSED LIVE PARTS ON THE OTHER SIDE.
30in.(760mm) MINIMUM OR WIDTH OF ENCLOSURE, WHICH EVER IS GREATER	78in.(1980mm) MINIMUM OR HEIGHT OF ENCLOSURE, WHICH EVER IS GREATER	36in.(915mm) MINIMUM	42in.(1065mm) MINIMUM	48in.(1220mm) MINIMUM

★Concrete, brick or tile walls shall be considered as grounded.

## Qualified Person

A Qualified Person is one who, by possession of a recognized degree, certificate, or professional standing, or who by extensive knowledge, training, and experience, has successfully demonstrated his/her ability to solve or resolve problems related to the subject matter, the work, or the project.

Only qualified persons may work on electric circuit parts or equipment that have not been de-energized.

Refer to U.S. Occupational Safety & Health Administration (OSHA) Regulations Standards - 29 CFR 1926.32(m) and 1910.333, or applicable national, state or local regulations for additional information.

# SAFETY

---

## Overhead Power Lines

Assembling, towing or transporting irrigation machine components such as but not limited to the pivot point, linear cart, span/drive unit assemblies, overhangs and/or corner assemblies underneath or near power lines is extremely dangerous because of the risk of electrocution.

Operating equipment that elevates irrigation machine components, such as but not limited to an aerial lift or crane, near power lines is extremely dangerous because of the risk of electrocution. Only qualified personnel should operate this type of equipment. Before operating the equipment, qualified personnel must read the equipment manufacturers' operating and safety instructions.

Refer to U.S. Occupational Safety & Health Administration (OSHA) Regulations (Standards - 29 CFR) Cranes and derricks. - 1926.550, or any other applicable national, state or local regulations for additional information.

- Always presume that any overhead power line is an energized line unless and until the person(s) owning the line and/or the electrical utility authorities indicate that it is not an energized line and it has been visibly grounded.
- Before operating any equipment near any power line make sure the line has been de-energized and visibly grounded at the point of work.
- Electrocution can occur without touching an electrical power line. Electricity, depending on the magnitude, can jump or become induced into equipment or conductive materials that come in close proximity to, but do not touch a power line. High wind, lightning, wet ground and other environmental conditions will increase the possibility of electrocution and require additional consideration.
- Transmitter towers can induce the equipment or materials being handled with an electrical charge. Before working or operating equipment near transmitter towers, make sure the transmitter is de-energized.
- Select the location where the span/drive unit will be assembled to ensure that neither the irrigation machine, or the equipment used during the assembly process, will violate the minimum clearance guidelines.
- Never operate equipment or allow the load, ropes or tag lines within 10 ft (3.05 m) of any power line rated 50 kV or lower whether it is energized or not. For lines rated over 50 kV, the minimum clearance shall be 10 ft (3.05 m) plus 0.4 inch (1.1 cm) for each kV over 50 kVs.
- Never assemble, tow, transport or allow irrigation machine components underneath or within 10 ft (3.05 m) of any power line rated 50 kV or lower whether it is energized or not. For lines rated over 50 kV, the minimum clearance shall be 10 ft (3.05 m) plus 0.4 inch (1.1 cm) for each kV over 50 kVs. Overhang support angles, cables and spinner drive components regularly extend 10 ft to 12 ft (3.1 m to 3.7 m) above the irrigation pipeline (span).
- Use barricades to identify areas where interference with overhead power lines could occur. Keep the assembly, towing or transporting of irrigation machine components and the operation of equipment including load, ropes or tag lines away from any power line, in the distances described above, whether the line is energized or not.
- Always designate a person to observe clearance between the power line and all equipment being operated or moved in order to give timely warning for all operations to STOP if the minimum clearance is violated.

## Minimal Lockout / Tagout Procedure

The following procedure establishes the minimum requirements for the lockout of energy isolating devices whenever maintenance or servicing is done on machines or equipment. It is used to ensure that the machine or equipment is stopped, isolated from all potentially hazardous energy sources and locked out before personnel perform any servicing or maintenance where the unexpectedly energized or start-up of the machine or equipment or release of stored energy could cause injury. All personnel, upon observing a machine or piece of equipment which is locked out to perform servicing or maintenance shall not attempt to start, energize, or use that machine or equipment.

When the energy isolating devices are not lockable, tagout should be used and affected personnel must wear full personal protection.

Refer to U.S. Occupational Safety & Health Administration (OSHA) Regulations (Standards - 29 CFR) Typical minimal lockout procedures - 1910.147 App A, or applicable national, state or local regulations, for additional information.

## Sequence of Lockout

1. Notify all affected personnel that servicing or maintenance is required on a machine or equipment and that the machine or equipment must be shut down and locked out to perform the servicing or maintenance.
2. The authorized personnel shall identify the type and magnitude of the energy that the machine or equipment utilizes, shall understand the hazards of the energy, and shall know the methods to control the energy.
3. If the machine or equipment is operating, shut it down by the normal stopping procedure (depress the stop button, open switch, close valve, etc.).
4. De-activate the energy isolating device(s) so that the machine or equipment is isolated from the energy source(s).
5. Lock out the energy isolating device(s) with assigned individual lock(s).
6. Stored or residual energy (such as that in capacitors, springs, elevated machine members, rotating fly-wheels, hydraulic systems, and air, gas, steam, or water pressure, etc.) must be dissipated or restrained by methods such as grounding, repositioning, blocking, bleeding down, etc.
7. Ensure that the equipment is disconnected from the energy source(s) by first checking that no personnel are exposed, then verify the isolation of the equipment by operating the push button or other normal operating control(s) or by testing to make certain the equipment will not operate. CAUTION: Return operating control(s) to neutral or "off" position after verifying the isolation of the equipment.
8. The machine or equipment is now locked out.

### **DANGER**

**•WHEN PERSONNEL WILL BE EXPOSED TO CIRCUIT ELEMENTS AND ELECTRICAL PARTS, A QUALIFIED PERSON MUST USE TEST EQUIPMENT TO VERIFY THAT THE CIRCUIT ELEMENTS AND EQUIPMENT PARTS OF THE EQUIPMENT ARE DE-ENERGIZED.**

## Restoring Equipment to Service

When the servicing or maintenance is completed and the machine or equipment is ready to return to normal operating condition, the following steps shall be taken:

1. Check the machine or equipment and the immediate area around the machine to ensure that non-essential items are removed and that the machine or equipment components are operationally intact.
2. Check the work area to ensure that all personnel are safely positioned or removed from the area.
3. Verify that the controls are in neutral.
4. Remove the lockout devices and re-energize the machine or equipment.
5. Notify affected personnel that the servicing or maintenance is completed and the machine or equipment is ready to be used.

# SAFETY

## Operate Safely

Valley Irrigation machines are designed with safety in mind. However, if this machine is operated incorrectly, it may pose a safety threat to the operator. A good safety program is much like a chain, it is only as strong as its weakest link. The manufacturer, dealer, and operator must maintain and improve all safety programs. Following is a list of safety operating tips which you and all other persons servicing or operating the machine must read and understand.

### CAUTION

- **DO NOT OPERATE THIS MACHINE WITHOUT FIRST READING THE OWNER'S MANUALS FOR THE MACHINE.**
- **READ ALL SAFETY MESSAGES IN THIS MANUAL AND SAFETY SIGNS ON THE MACHINE.**
- **DO NOT LET ANYONE OPERATE THIS MACHINE WITHOUT PROPER INSTRUCTIONS.**
- **UNAUTHORIZED MODIFICATIONS MAY IMPAIR THE FUNCTION AND/OR SAFETY OF THE MACHINE.**
- **IF YOU DO NOT UNDERSTAND ANY PART OF THIS MANUAL, CONTACT YOUR VALLEY DEALER.**

### EMPLOYEE INSTRUCTION ON SAFETY

It is very important to instruct your employees on the safe use of this equipment at the time of their initial assignment to operate it. DO NOT let anyone operate this equipment without proper instructions.

Safety training should be presented annually and the service manager should ensure employees fully understand the safety messages and what to do in case of emergencies.

### EMERGENCY STOPPING

The machine can be stopped at any time at any tower by turning the disconnect switch, located underneath the tower box, to the OFF position. See Figure 14-1.

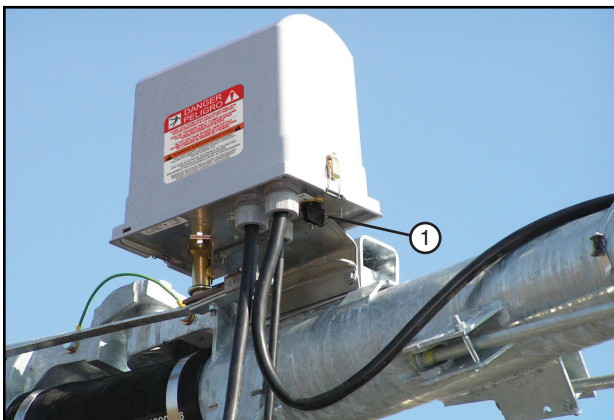

Figure 14-1 1. Disconnect Switch

### WARNING

#### PROPER GROUNDING

DO NOT attempt to start the machine until the electrical service is properly installed and grounded by a qualified electrician as per the electrical standards.

If the power supplied to the machine is not grounded properly, severe injury or death can result should an electrical malfunction occur.

It is your responsibility to ensure that your power supplier and/or electrical contractor has grounded the irrigation machine as required by the National Electrical Code and by applicable local electrical codes. If a machine is properly grounded and fuse sizing is correct, there is extremely low probability of an individual being injured by electrical shock.

### NOTE

- **All 480 VAC, 60 Hz. (380 VAC, 50 Hz.) power supply services MUST be a 4 conductor service. Three 480 VAC (380 VAC) power lines and one ground conductor which is as large as the power carrying conductors for that service.**

## Operate Safely

### **DANGER**

#### DISCONNECT POWER WHEN SERVICING

ALWAYS disconnect electrical power before servicing or performing maintenance to the machine.

If you are going to perform maintenance on the machine, YOU MUST shut off and lock the main power disconnect as shown below. See figure 15-1.

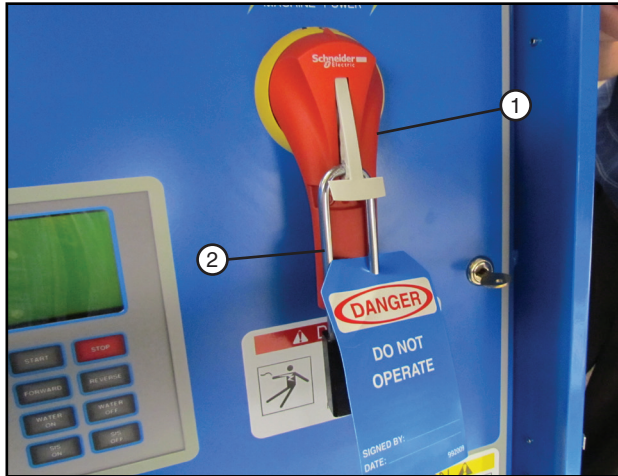

Figure 15-1 1. Main Power Disconnect  
2. Lock

The blue (OSHA safety color code) tag shown below should also be filled out and attached to the disconnect after locking. See figure 15-2.

The tag should reveal the name of a person to contact before restoring power to the machine.



Figure 15-2

### **CAUTION**

#### QUALIFIED SERVICE PERSONNEL

If you do not understand electricity or other parts of the machine, have qualified service personnel perform any hazardous repairs or maintenance.

### **CAUTION**

#### GUARD ALL POWER TAKE-OFF DRIVES

This includes all belt and power line drives.

Replace any guards and shields removed for maintenance.

### **WARNING**

#### MARK AND GUARD ALL POWER LINES

Do NOT deep rip or chisel near the buried power service wires.

Do NOT deep rip in a circle at the drive unit. The deep chisel track will cause severe stresses on the structure.

If you do deep rip your field, run the machine with the percent timer at 100% for the first revolution.

### **WARNING**

#### SUSPECTED SHORT CIRCUITS

DO NOT touch the machine if you suspect a short-circuit situation. Call a qualified electrician or an authorized Valley dealer immediately.

Circumstances which may cause you to suspect hazardous voltage situations may include:

- Physical damage to the machine or span cable
- Recent electrical storms (lightning)
- Unusual operating characteristics of the machine

If you suspect a short circuit due to feeling a rippling tingle when touching the machine, DO NOT touch the machine again. Call a qualified electrician or an authorized Valley dealer immediately.

### **WARNING**

#### LIGHTNING AND THE MACHINE

Stay away from the machine during an electrical storm. An irrigation machine makes a good path to earth. It is also probably the tallest object in the field, which makes it a good lightning receptor!

# SAFETY

## Operate Safely

### CAUTION

#### **DO NOT OVERSIZE FUSES**

Fuses are sized for the protection of a specific machine.

Be certain you have the proper fuse sizes in place before initial start-up and when replacing fuses.

### CAUTION

#### **PLUG - IN CONNECTORS**

Disconnect power before connecting or disconnecting any plug-in connectors.

### CAUTION

#### **DO NOT OPERATE AT FREEZING TEMPERATURES**

Spraying water has a cooling effect and water will freeze even though the air temperature is slightly above freezing.

Shut the machine down at 40 degrees Fahrenheit (4.5 degrees Celsius). Do not operate machine when temperature is below 40° F (4.5° C).

- **DAMAGE TO EQUIPMENT RESULTING FROM FREEZE-UP IS NOT COVERED UNDER WARRANTY.**
- **IT IS IMPORTANT TO MAKE SURE ALL PIPE DRAINS FUNCTION PROPERLY TO PREVENT PIPELINE FREEZE-UP DURING COLD WEATHER.**

### CAUTION

#### **AVOID HIGH PRESSURE WATER STREAMS**

Avoid body contact with high pressure water streams.

### WARNING

#### **AVOID CHEMICALS**

Avoid exposure to sprinkler spray while chemicals are being injected into the water. Read EPA Label Improvement Program (PR Notice 87-1) and all instructions for chemical applications.

If you plan on chemigating, make certain you have complied with state or local regulations in regard to safety equipment, certification, operation and calibration of the injector pump. Make certain you have first aid and fresh water available in case of an accident. You must also be familiar with the correct cleanup procedures in case of a spill.

- **USE OF PROTECTIVE CLOTHING IS RECOMMENDED WHEN HANDLING CHEMICALS. SAFETY GLASSES, GLOVES, AND PROTECTIVE OUTERWEAR SHOULD BE WORN WHEN HANDLING CHEMICALS.**
- **CONTAMINATION OF THE WATER SUPPLY MAY OCCUR IF EFFECTIVE SAFETY DEVICES ARE NOT INSTALLED/USED IN CONNECTION WITH INJECTION EQUIPMENT FOR CHEMIGATION.**

### DANGER

#### **DRIVE SHAFTS START WITHOUT WARNING**

An electric motor on each tower of the center pivot powers two or more drive shafts connected to wheel gear drives. These drive shafts start and stop without warning.

- **DO NOT TOUCH ROTATING DRIVE SHAFT OR SHIELD, CLOTHING OR LIMBS MAY BECOME ENTANGLED, RESULTING IN SEVERE INJURY.**
- **DO NOT SERVICE THE MACHINE UNTIL THE MAIN DISCONNECT IS LOCKED IN THE OFF POSITION.**
- **ALWAYS REPLACE DRIVE SHAFT SHIELDS AFTER SERVICING.**
- **DRIVE SHAFT SHIELDS MUST ALWAYS BE IN PLACE WHEN OPERATING THE MACHINE.**

### CAUTION

#### **CHECK WHEEL TRACKS BEFORE STARTING**

Make sure all objects, livestock or persons are clear of the machine before starting. Drive trains are powerful and can climb over vehicles, equipment, etc.



# SAFETY

## Operate Safely

### CAUTION

#### KEEP CHILDREN AWAY

Irrigation Machines are NOT playground equipment. Prevent children from playing or climbing around on the machine. This can be extremely dangerous, especially if the machine is operating.

### CAUTION

#### CHECK MACHINE DIRECTION

DO NOT operate the machine if it moves in the direction opposite to that which was chosen.

Forward should be clockwise and reverse counter-clockwise.

### CAUTION

#### KEEP WATER OFF ROADWAYS

It is against the law in most states to allow water to spray on state and county roadways. This is a serious hazard to passing motorists.

If end guns are used, make sure you read and understand the correct procedures for setting the on and off positions to avoid watering the roadways.

If an end gun is watering a roadway, immediately discontinue use and adjust the shutoff setting or call your Valley dealer to repair the end gun shut off mechanism.

### CAUTION

#### AUTO REVERSE OPERATION SAFETY

If the machine reverses direction at a roadway or a physical object such as a building, tree line, power pole, etc., then you MUST provide a backup device to stop the machine if the reversing mechanism were to fail. See figure 17-1.

Contact your Valley dealer for more information concerning physical barricades for machines under these circumstances.



Figure 17-1 1. Physical Barricade

### CAUTION

#### PROPER USE OF THE SAFETY OVERRIDE

Caution MUST be taken by the operator when using the safety override function as it will bypass or disable all of the machine's automatic safety shutdown circuits.

- NEVER DEPRESS AND HOLD THE START/STOP SAFETY OVERRIDE SWITCH IN THE START POSITION FOR MORE THAN 3 TO 5 SECONDS.

If the machine is not in full view by the operator, do not use the Safety Override function.

The operator MUST inspect the entire machine between each safety override start attempt.

Repeated safety override start attempts can cause severe structural damage.

Call your Valley dealer if the machine fails to start.

# SAFETY

## Safety Decals

These Danger, Warning, and Caution decals appear in various locations on a Valley irrigation machine. You MUST familiarize yourself and other operators with these safety decals. For replacement of any decal, contact your local Valley dealer.

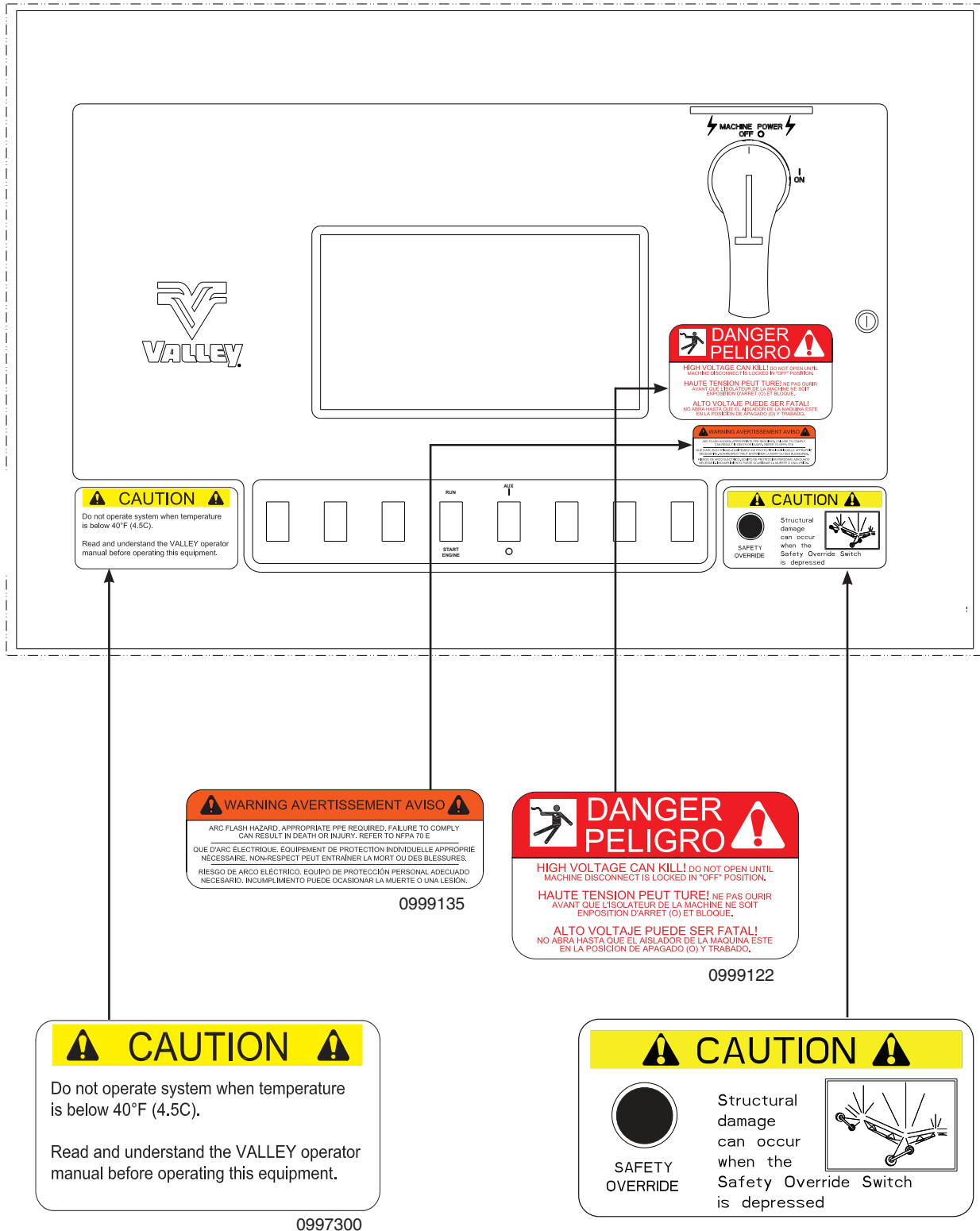





# SAFETY

## Safety Decals

 <b>WARNING</b>	
Improper installation of this motor may result in fire, explosion, electrical shock or other personal injuries. Read operating instructions	
	Disconnect power before maintenance. Open all circuits before removing conduit box cover. Be sure motor is properly grounded per local and national codes.
	Do not place fingers or objects near openings.
	Do not use eye bolts or lifting hooks to lift anything except the product.

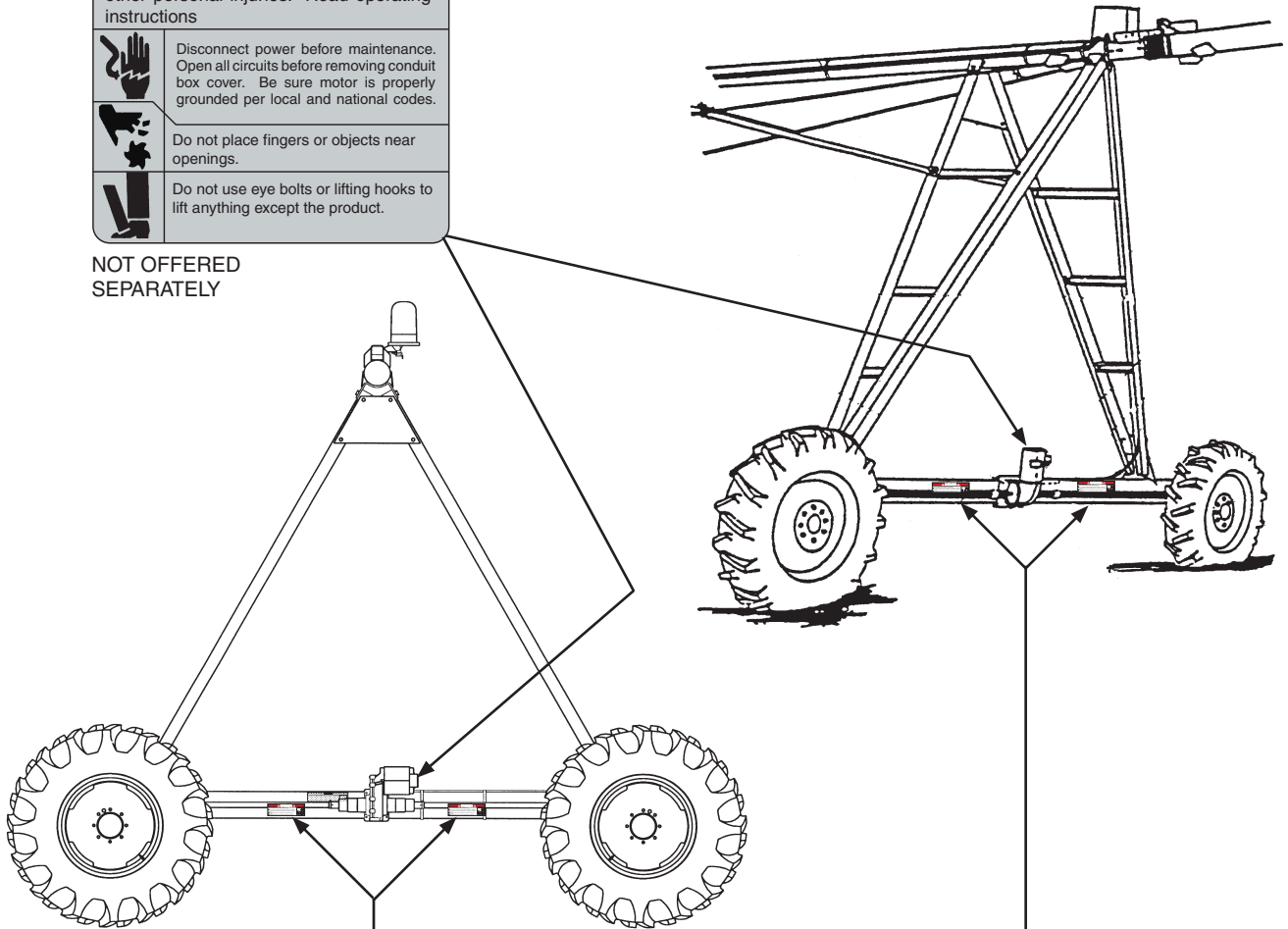
NOT OFFERED  
SEPARATELY

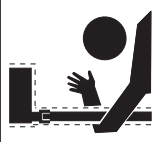

 <b>DANGER</b> 	
<b>Drive Shaft Starts Without Warning!</b>	
<ul style="list-style-type: none"><li>Do not touch rotating drive shaft or shield. Clothing or limbs may become entangled, resulting in severe injury.</li><li>Do not service until machine is locked in the off position.</li><li>Always replace drive shaft shield after servicing.</li></ul>	

0994146

# SAFETY

## Safety Decals



0991532

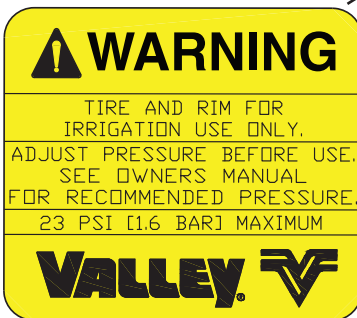
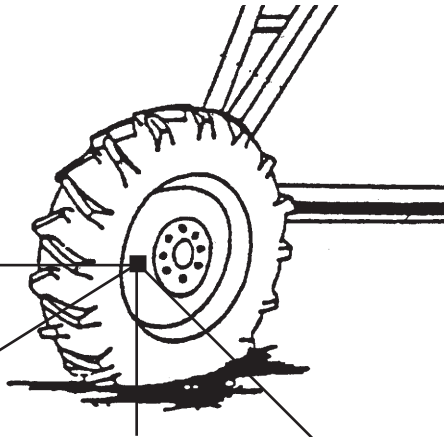

0991593

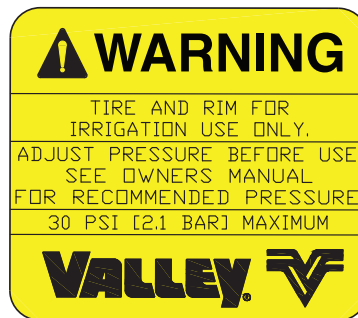

0991366

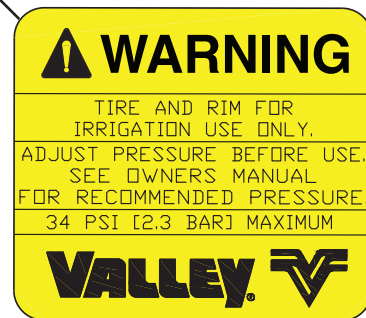

0996109

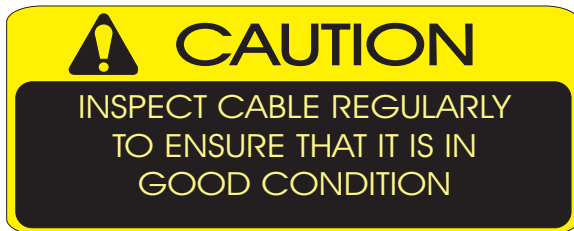

Part No. 0992750

Location: Remote public power installations



Part No. 0992748

Location: Remote public power package

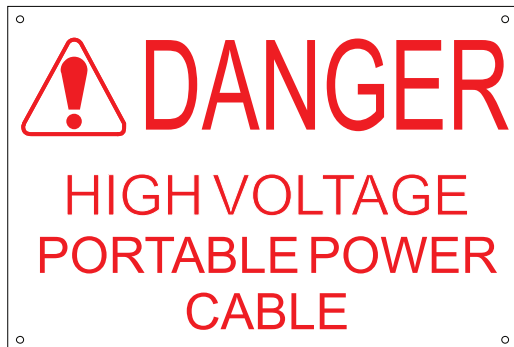

Part No. 1732291

Location: Remote public power installations



Part No. 0992749

Location: remote public power installations

## 2 Wheel Linear

There are two different types of 2 Wheel Linear machines, the standard linear and the swing around linear. Both 2 Wheel Linear machines are end feed machines that can be either non-tow or towable.

### End Feed Machine

If the water supply is located at the edge of the field, the 2 Wheel Linear Cart will be the end tower adjacent to the water supply pipeline or ditch.

The central pulse tower box is always on the opposite end of the system from the two wheel cart and is located at the second tower from the end. Linear intermediate tower boxes are installed on both ends of the free-standing span. The span safety box is on the span directly over the control panel or cart and only one end tower box located on the other end of the system. All other tower boxes are intermediate tower boxes. See figure 21-1 and 23-2.

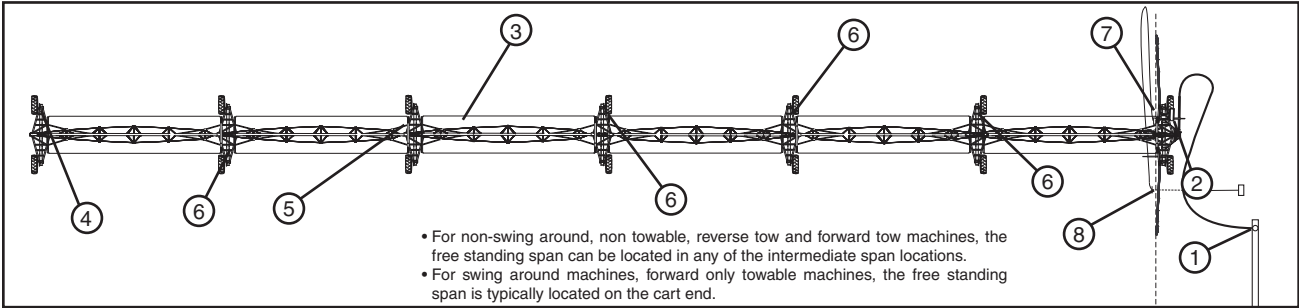

Figure 21-1 Closed Delivery Hose Drag Shown: 1. Hose Feed Water Supply 5. Central Pulse Tower Box  
 2. 2 Wheel Cart 6. Intermediate Tower Box  
 3. Free Standing Span 7. Span Safety Box  
 4. End Tower Box 8. Furrow Guidance Shown

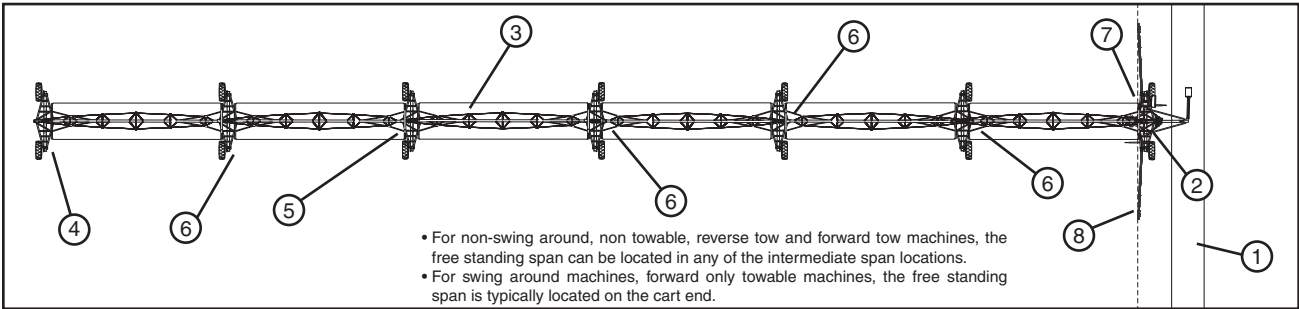

Figure 21-2 Open Delivery Hose Drag Shown: 1. Ditch Feed Water Supply 5. Central Pulse Tower Box  
 2. 2 Wheel Cart 6. Intermediate Tower Box  
 3. Free Standing Span 7. Span Safety Box  
 4. End Tower Box 8. Furrow Guidance Shown

Center Drive Motor RPM			
Motor Type	Cart Motor RPM	Intermediate Drive Unit Motor RPM	Last Regular Drive Unit Motor Rpm
Standard Speed	34	43	34
High Speed	56	68	56

Figure 21-3

# OVERVIEW

## Spans

Water is transported across the field through a pipeline. The pipeline is made up of a series of spans which are connected together. Each span consists of truss assemblies and truss rods to support the span a tower box that acts as a junction box for the span cable and motor lead, and a drive tower which moves the pipeline across the field. See figure 22-1.

## Drive Towers

Power to the electric motor on the center drive gearbox is supplied by the tower box. The center drive gearbox drives the wheel gearboxes. See figure 22-2.

## Hitch

The spans are attached to each other with a ball hitch and cup assembly which gives lateral, rotational, and vertical flexibility between the spans. See figure 22-3.

The span pipeline is connected together with a flexible hose and held in place with band clamps. See figure 22-3.

## Overhang

Typically an overhang is attached to the end of the last span pipe and used for irrigation beyond the span/drive unit. Support ears and cables provide support for the overhang. See figure 22-4.

## End Gun

Typically a booster pump is installed and an end gun is attached at the end of the overhang and used to increase the area irrigated beyond the end of the machine. See figure 22-5.

The end gun is set to cover a specified area. This area is determined by the forward and backward angles, which are referred to as the end gun arc settings. See Figure 22-6.

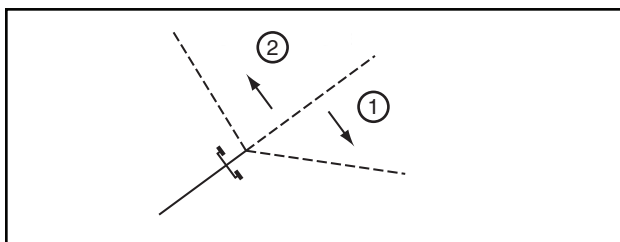

Figure 22-6 1. Forward Angle  
2. Backward Angle

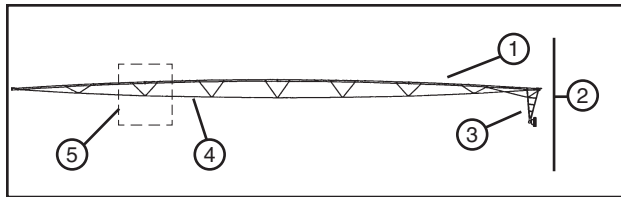

Figure 22-1 1. Pipeline  
2. Span  
3. Drive tower  
4. Truss rod  
5. Truss assembly

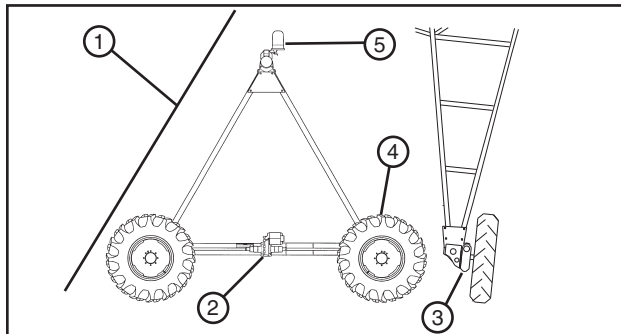

Figure 22-2 1. Drive Tower  
2. Center Drive Gearbox  
3. Wheel Gearbox  
4. Tire And Wheel Assy  
5. Tower Box

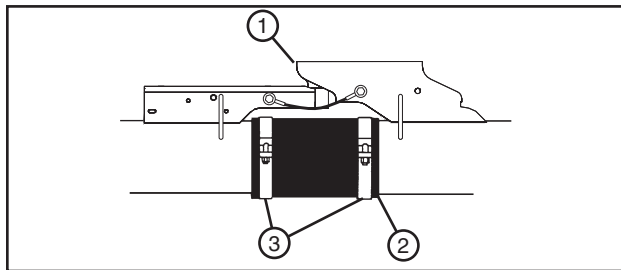

Figure 22-3 1. Ball Hitch And Cup Assembly  
2. Flexible Hose  
3. Band Clamp

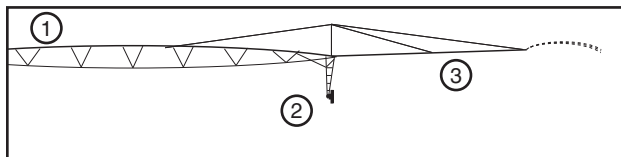

Figure 22-4 1. Span  
2. Drive Unit  
3. Overhang

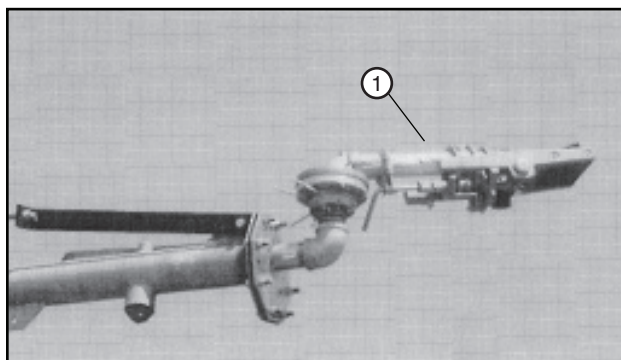

Figure 22-5 1. End Gun

## Water Application

A sprinkler chart provides the operator with information about water application depths and pass times at different percent timer settings.

Water is applied to the field through the sprinklers. Sprinklers can be mounted on top of the pipeline or on drop tubes that hang below the pipeline. See figure 23-1.

## Span Safety Box

The span safety box is located over the 2 wheel linear cart. See figure 23-2.

The span safety box will shut down the machine if the span is out of alignment.

See Maintenance section for adjustment procedure.

## Span Cable

A cable with color coded wires enters and leaves each tower box. The cable runs the entire length of the machine and is referred to as span cable. See figure 23-3.

The span cable can carry multiple voltages including high voltage depending on control panel and the country of use.

## Intermediate Tower Boxes

The intermediate tower control boxes provide power to the center drive gear motors depending on the tower box position in relationship to the next tower in the system. See figure 23-3.

## Last Tower Box

The last tower control box provides power to the center drive gear motor depending on the percent timer setting at the control panel. It also completes

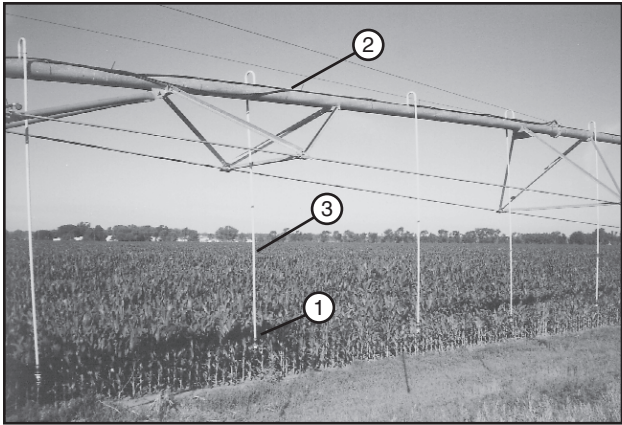

Figure 23-1 1. Sprinkler  
2. Pipeline  
3. Drop Tube

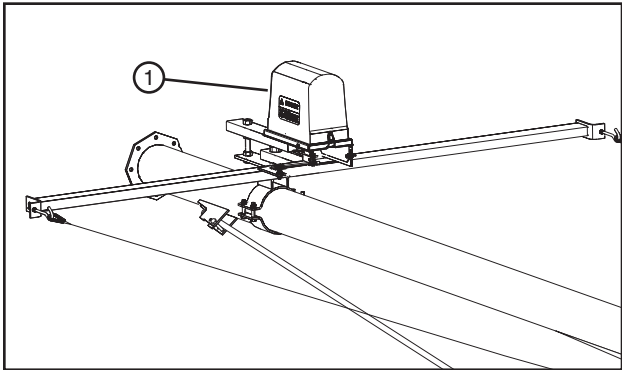

Figure 23-2 1. Span Safety Box

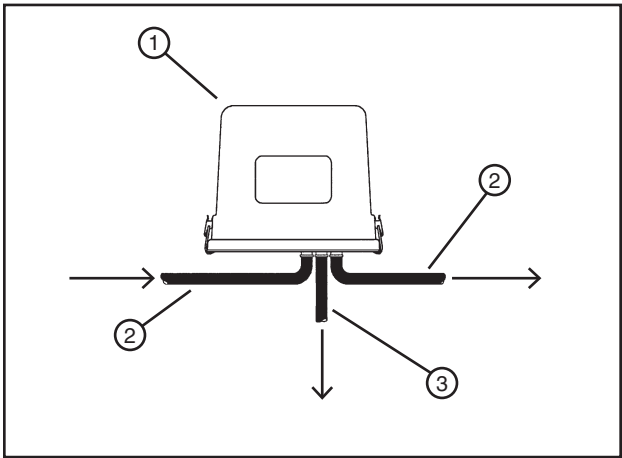

Figure 23-3 1. Tower Box 2. Span Cable 3. Cable To Drive Motor

# OVERVIEW

## Central Pulse Tower Box

The central pulse tower box provides power to the center drive gear motor depending on its position in relationship to the last tower and the machine's angle to the guidance system.

The basic components include safety microswitch, run microswitch, motor contactor, disconnect, overwatering timer, and pulse timer. See figure 24-1.

The overwatering timer is a safety device used to shut the system off if one of the end towers fail to move during the overwatering timer cycle. See figure 24-2.

The overwatering timer cycle is adjustable from 0 to 60 minutes.

Each time the central pulse tower moves, the overwatering timer is reset and another timer cycle begins.

The pulse timer is part of the linear steering system. See figure 24-3.

During operation, the linear machine moves at a 90° angle to the guidance system. If this angle changes, the linear irrigation machine must steer itself back to the correct operating position.

When the linear machine steers, the pulse timer restricts the run time of the leading end tower to a percentage of the run time of the tower where the pulse timer is located. This allows the trailing end tower to catch up, while minimizing radical steering and possible structural damage.

The pulse timer dial is factory set to 20 percent and sealed in position.

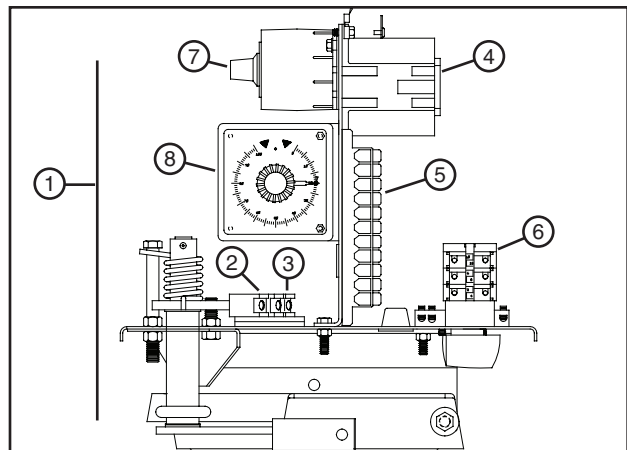

Figure 24-1 1. Central pulse tower box 5. Terminal block  
2. Safety microswitch 6. Disconnect  
3. Run microswitch 7. Overwatering timer  
4. Motor contactor 8. Pulse timer

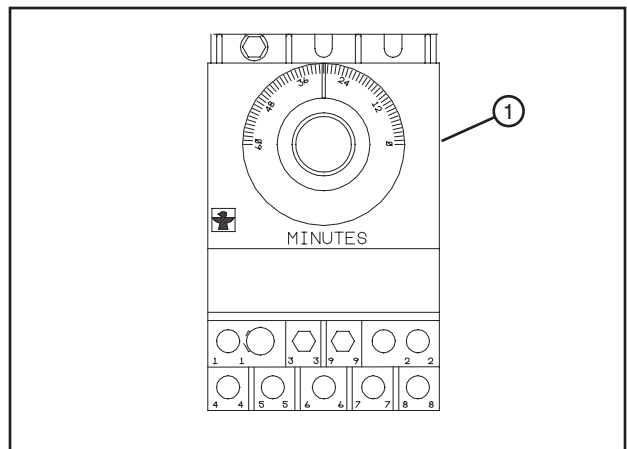

Figure 24-2 1. Overwatering timer

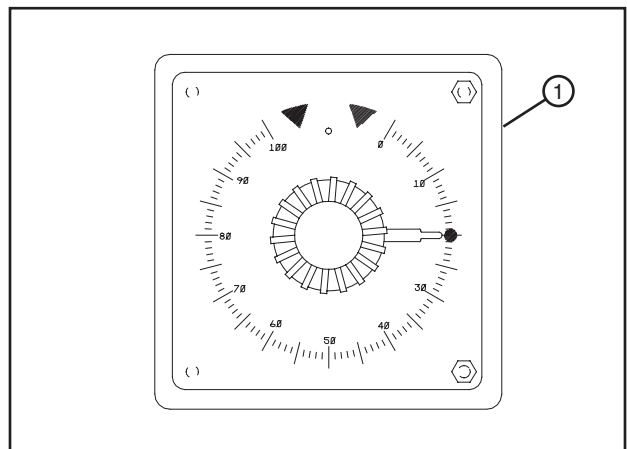

Figure 24-3 1. Pulse timer



## Safety Circuit

The safety circuit is a 120 volt AC control circuit that starts in the control panel and runs the entire length of the machine See figure 25-1.

Each drive tower box contains a safety microswitch. The safety microswitches must be closed to complete the safety circuit.

## Alignment

There are 2 types of span alignment for linear machines, modified or floating alignment. The type of alignment used depends on the number of spans.

- Linear machines with five spans or less can use modified or floating alignment. See figures 25-2 and 25-3.
- Linear machines with six spans or more must use floating alignment.

The end tower is the controlling tower. As the end tower moves, all of the other towers move to maintain straight alignment.

When the end towers move, they create an angular deflection with the next tower, this closes the run microswitches and causes the next tower to move.

This cycle repeats itself throughout the length of the entire machine.

The result of these cycles is that any tower can be moving at any time, depending on its relationship with the next outer span.

See Maintenance section for adjustment procedure.

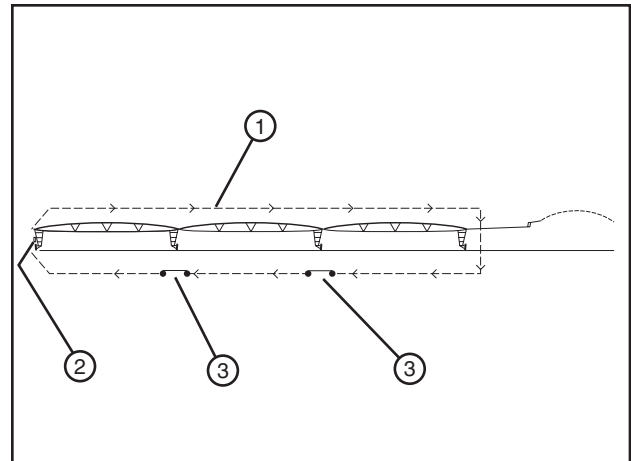

Figure 25-1 1. Safety circuit  
2. Control panel  
3. Safety Microswitch



Figure 25-2 Modified alignment



Figure 25-3 Floating alignment

# OVERVIEW

## Guidance System

There are 3 types of guidance for 2 wheel linear machines, below ground, furrow and GPS guidance .

### Below Ground Guidance (Option)

The below ground guidance system consists of a buried single loop wire running through the center of the field, a guidance box, and five antennas mounted on the machine. A slight curve of the buried wire at each end of the field is necessary to counter the effects of the return wire electrical field.

The five antennas are normally located in the middle of the free-standing span, attached to a tube suspended from the truss rods. Two safety and one reference antenna are located in the middle of the tube, and on each end there is a steering antenna; one forward and one reverse. See figure 26-1.

### Furrow Guidance (Option)

The furrow guidance system consists of two furrow guidance boxes, arms, and skids mounted on the linear cart. The skids follow a furrow running the length of the field. See figure 26-2.

The skids follow a “V” shaped furrow, 4 in to 6 in (101.6 mm - 152.4 mm) deep, running the length of the field. See Maintenance section for detailed instructions on furrow maintenance and construction.

If the linear cart moves away from the furrow, the guidance arm will actuate a steer switch bringing the linear cart back into the correct position. If the steer switch fails, a back-up safety switch would shut the machine down.

### GPS Guidance (Option)

The GPS guidance system consists of the GPS receiver which is mounted on the top of the machine. The base station which is responsible for sending position correction data to the receiver on the machine. The satellite sends GPS position data to both the base station and the receiver. See figure 26-3.

To ensure that the linear cart moves correctly. The GPS system waits for the Position Uncertainty to be less than .04 M (4 cm) before allowing the machine to move.

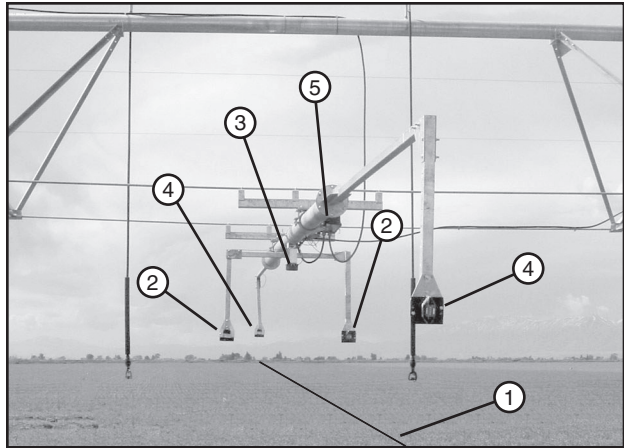

Figure 26-1 1. Buried wire location 4. Steering antenna  
2. Safety antenna 5. Guidance box  
3. Reference antenna

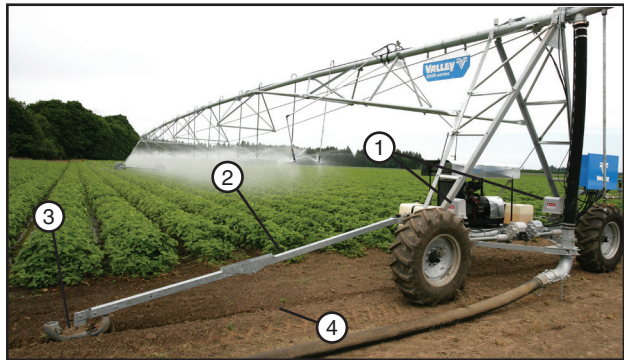

Figure 26-2 1. Guidance Box 3. Skid  
2. Guidance Arm 4. Furrow

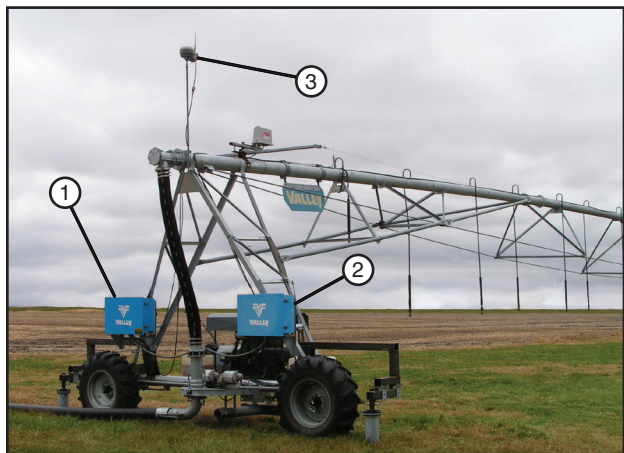

Figure 26-3 1. Machine Control Panel  
2. GGS Control Panel  
3. GPS Receiver



## Cart Mounted AR/AS Box (Option)

The Auto Reverse/Auto Stop box provides the machine the ability to Auto Reverse and Auto Stop.

The Auto Reverse/Auto Stop Box is mounted on the Linear Cart and is only used with the Auto Reverse/Auto Stop option.

The basic components include a safety microswitch, run microswitch, terminal block, and disconnect. See figure 27-1.

## Engine Generator (Option)

The engine generator option is attached to the base beam. See figure 27-2.

## Fuel Tank (Engine Generator Only)

The fuel tank has a capacity of 30 gallons and is equipped with a vented cap. Two fuel tanks can be mounted on the linear cart. See figure 27-2.

## Cart Mounted End Of Field And Hose Stop Switch

The end of field, hose and cord stop switch is mounted on the linear cart and a stop post is placed at each end of the field or at the hose or cord length interval.

The basic components include a microswitch and switch arm. See figure 27-3.

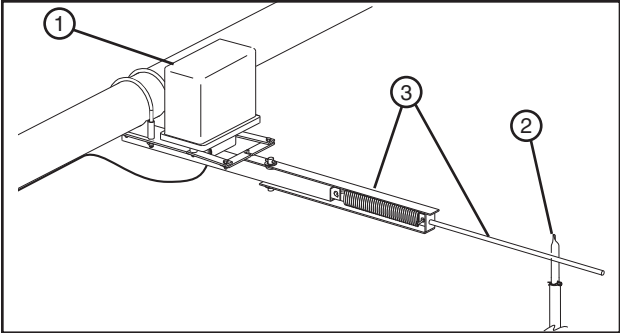

Figure 27-1 1. AR/AS Box 2. Stop Post 3. AR/AS Switch Arm

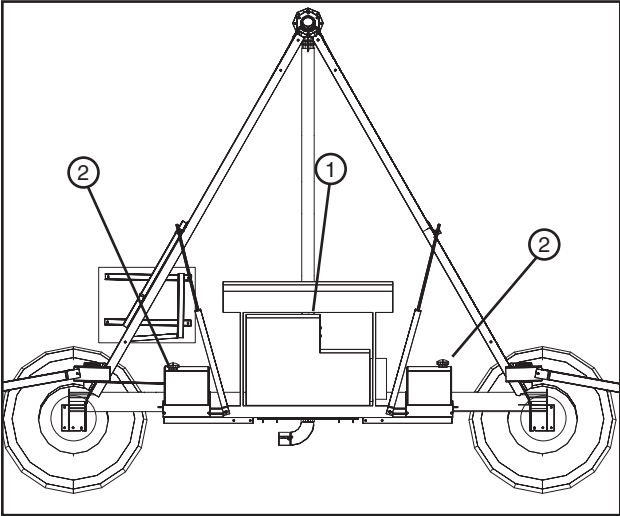

Figure 27-2 1. Engine Generator (OPTION) 2. Fuel Tank

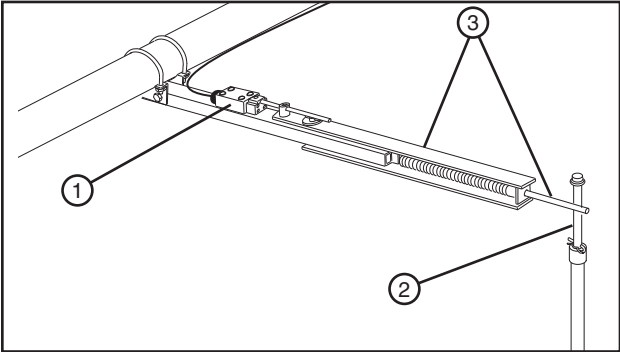

Figure 27-3 1. Stop Switch 2. Stop Post 3. Stop Switch Arm

# OVERVIEW

## Electric Cord Drag (Option)

The electric cord mounting with safety switch can be mounted horizontally or vertically on the cart. See figure 28-1.

The electric cord is spring loaded. If the electric cord is pulled beyond the limits of the safety switch setting, the safety switch opens to shut down the machine.

## Auto Reverse/Auto Stop Box (Option)

The Auto Reverse/Auto Stop box provides the machine the ability to Auto Reverse and Auto Stop.

The Auto Reverse/Auto Stop Box is mounted on the drive unit mounted end of field stop and is only used with the Auto Reverse/Auto Stop option.

The basic components include cams, safety microswitches, auto reverse microswitches, terminal block, and disconnect. See figure 30-2.

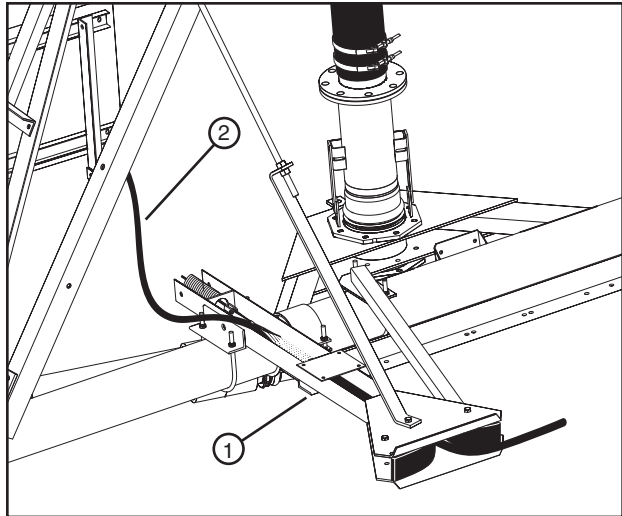

Figure 28-1 1. Electric Cord Mounting with Safety Switch  
2. Electric Cord

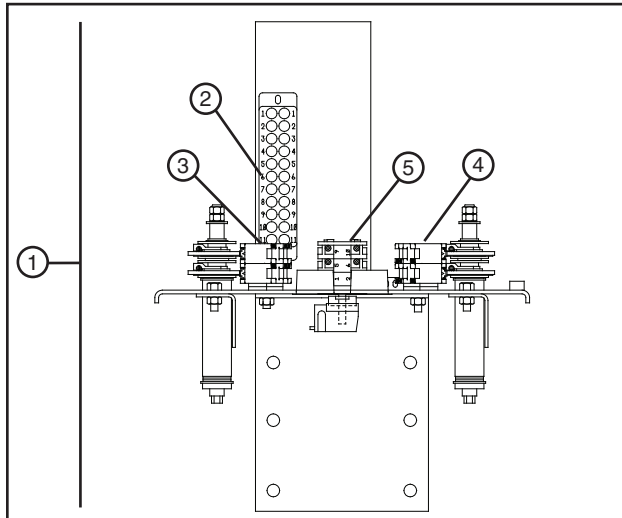

Figure 28-2 1. AR/AS Internal Switch Box  
2. Terminal Block  
3. Safety Microswitch  
4. Run Microswitch  
5. Disconnect

## Control Panel

The control panel allows the operator to control the machine. The control panel is located on the linear cart. See figure 29-1 and 29-2.

Basic functions controlled by the panel include:

1. Starting/Stopping
2. Selecting forward or reverse running direction
3. Selecting machine speed (which controls the amount of water being applied).

When the machine is started, the AC power is sent through the span cable to the tower boxes. The control circuit distributes the power to the drive motors through the motor contactors and the machine moves depending on the control panel settings.

Refer to the control panel owner's manual for detailed information about the control panel operation.

## Drive Unit Mounted End of Field Stop/Auto Reverse (Option)

The drive unit mounted end of field stop is used with both the end of field stop and end of field auto reverse option. See figure 29-3.

This mechanism will stop the system when the actuator arm contacts the barricade.

If the auto reverse option is installed, the operator can choose to either have the system stop or automatically reverse its direction of travel and continue to run.

**⚠ CAUTION**

- **NEVER USE THE SAFETY OVERRIDE BUTTON TO WALK THE MACHINE OFF OF THE BARRICADE. STRUCTURAL DAMAGE MAY RESULT.**
- **SOIL MAY BUILD UP IN THE WHEEL TRACK RESULTING IN A RAMP EFFECT ALLOWING THE ACTUATOR ARM TO GO OVER THE BARRICADES. REGULARLY MAINTAIN THE WHEEL TRACK TO INSURE THE ACTUATOR ARM ALWAYS CONTACTS THE BARRICADE.**

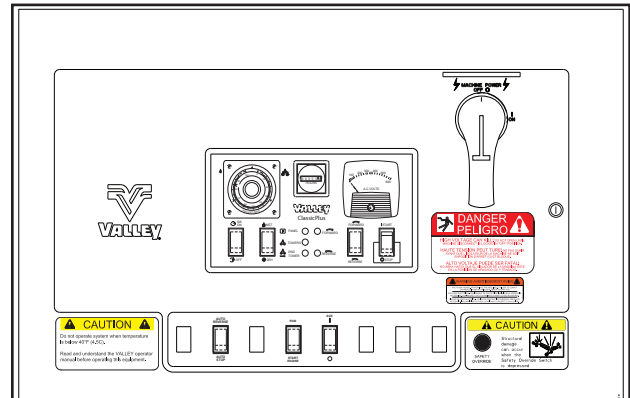

Figure 29-1 ClassicPlus Control Panel Shown

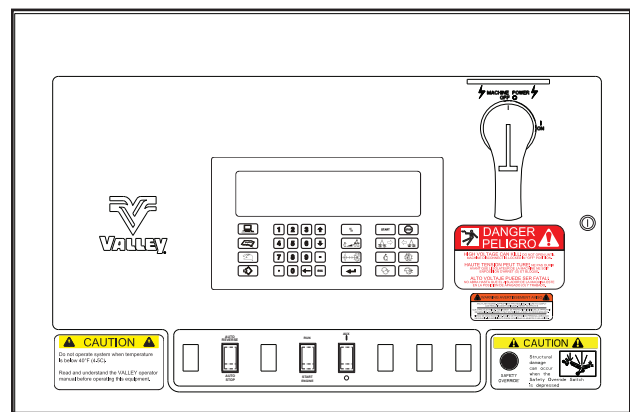

Figure 29-2 Valley AutoPilot Control Panel Shown

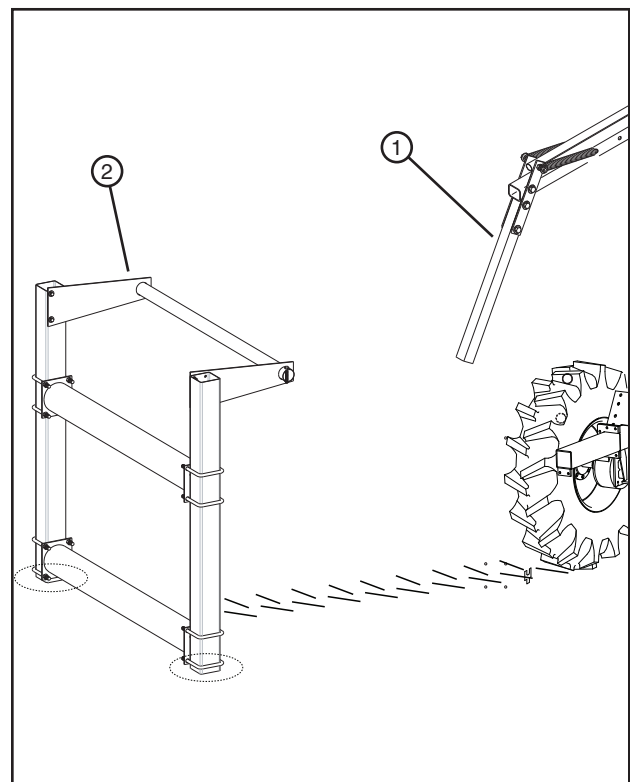

Figure 29-3 1. Actuator arm  
2. Barricade

# OVERVIEW

---

## Machine Operation

The 2 Wheel Linear was designed to be used on relatively level fields. You should not attempt to install a linear on any severe rolling or sloping terrain. Also, the cart path must be flat and free of any ruts or tracks which would force side loads into the cart frame. Should ruts develop in the cart path, the owner/operator should grade down the surface smooth and maintain it in that condition during irrigation season.

For proper operation of the 2 Wheel Linear machine, the Control Panel Owner's Manual and 2 Wheel Linear Owner's Manual must be used together.

The Control Panel Owner's Manual includes safety guidelines and explains the basic operation of the control panel itself, including how to start/stop the machine, change running direction and change water application amounts.

The 2 Wheel Linear Owner's Manual includes safety guidelines and explains the operation of the 2 Wheel Linear machine including how to establish wheel tracks, methods of operation, swing around operation, electric cord drag operation, hose and cord positioning, ditch feed operation and towing.

All Owner's, operators and maintenance personnel **MUST** read and understand the Control Panel Owner's Manual and the 2 Wheel Linear Owner's Manual.

## Overwatering Timer

The overwatering timer located in the central pulse tower box is a safety device used to shut the machine off should one or both of the end towers fail to move. The overwatering timer is set by the operator. See figure 31-1.

**⚠ DANGER**

- **THE TOWER BOXES CONTAIN HIGH VOLTAGE! 480 VOLTS CAN KILL.**
- **ALWAYS DISCONNECT ELECTRICAL POWER BEFORE SETTING THE OVERWATERING TIMER.**
- **ALWAYS REPLACE ANY COVER THAT WAS REMOVED TO MAKE OVERWATERING TIMER ADJUSTMENT.**

Refer to the chart for suggested overwatering timer settings based on the control panel percent timer setting. The times shown in the chart are actual minutes that the overwatering timer will allow the central pulse tower box drive unit to stand still before it shuts the machine off. See figure 31-2.

The times shown in the chart are actual minutes that the overwatering timer will allow the central pulse tower box drive unit to stand still before it shuts the machine off.

Each time the central pulse tower box drive unit moves the overwatering timer is reset and another time out cycle begins.

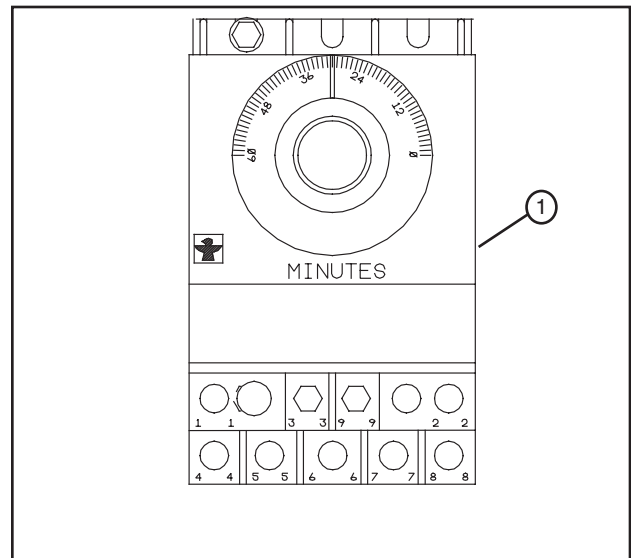

Figure 31-1 1. Overwatering Timer

<b>OVERWATERING TIMER SETTINGS</b>	
The overwatering timer should be set in relationship to the percent timer setting.	
Percent Timer Setting	Suggested Overwatering Timer Setting
90%	20 Minutes
80%	20 Minutes
60%	20 Minutes
40%	20 Minutes
30%	28 Minutes
10%	36 Minutes

Figure 31-2

# OPERATION

## End of Field, Hose and Cord StopSwitch

When the end of field, hose stop switch arm deflects against the stop post, the machine will stop.

The stop post must be removed before the machine can be restarted. See figure 32-1.

## Auto Reverse/Auto Stop (Option)

When the Auto Reverse/Auto Stop (AR/AS) switch arm deflects against the stop post, the machine will stop or reverse depending on the control panel's programming. See figure 32-2.

The stop post must be removed before the machine can be restarted.

## Stop Bracket

To ensure that the swivel inlet elbow works correctly when the machine is reversed. The swivel inlet must be angled away from the cart approximately 10 degrees as shown. See figure 32-3.

The stop bracket prevents the elbow inlet and hose from turning toward the cart when the machine changes direction.

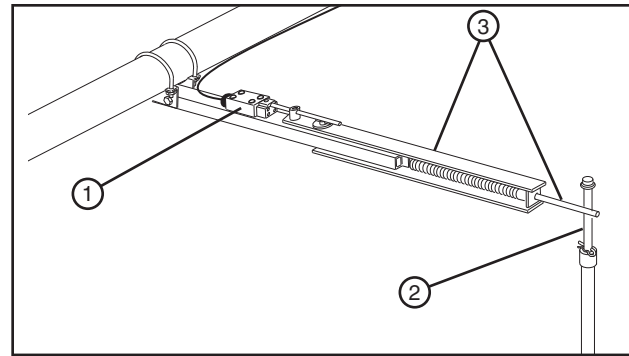

Figure 32-1 1. Stop Switch  
2. Stop Post  
3. Stop Switch Arm

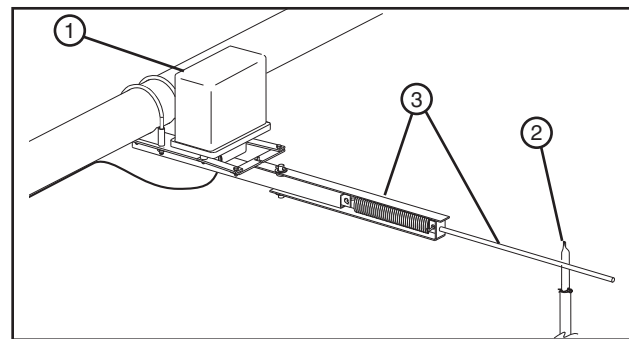

Figure 32-2 1. AR/AS Box  
2. Stop Post  
3. AR/AS Switch Arm

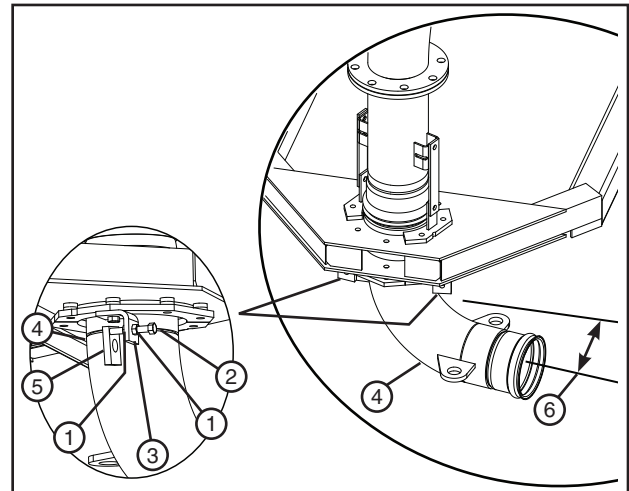

Figure 32-3 1. Jam Nut  
2. 1/2 x 3 Cap Screw  
3. Stop Bracket  
4. Side Inlet Elbow  
5. Stop Tab  
6. 10 Degrees

## Tee Inlet (Swing Around)

The tee inlet is used on the swing around linear.

To use the tee inlet, align the elbow inlet with the end of tee inlet. Slide the tee inlet into elbow inlet and secure in place by locking the bushings on each side of Tee Inlet down into the slots on hose pull plate. See figure 33-1.

## Furrow Guidance Arms

When pivoting the swing around linear or towing the towable linear, the furrow guidance arms must be folded up and secured against the cart drive tower with a tie down strap. See figure 33-2.

## Ditch Feed (Option)

The ditch feed option is available with either an Engine Generator powered pump or Electric powered pump. See figure 33-3.

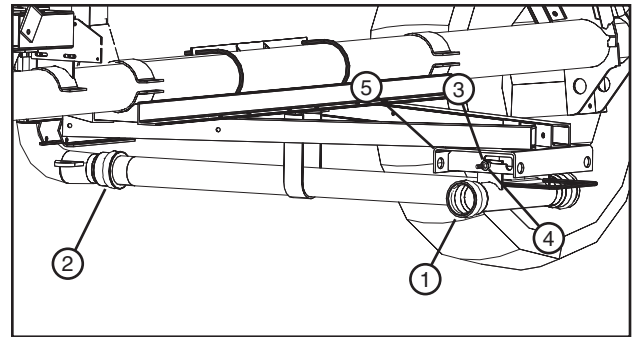

Figure 33-1 1. Tee Inlet  
2. Elbow Inlet  
3. Bushing  
4. Slot  
5. Hose Pull Plate

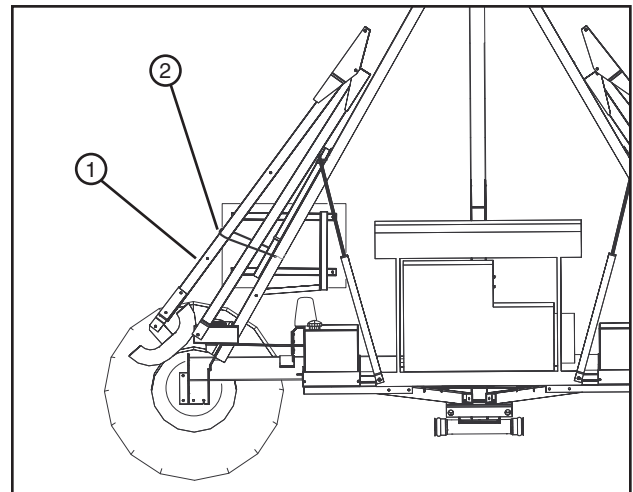

Figure 33-2 1. Guidance Arm  
2. Tie down strap

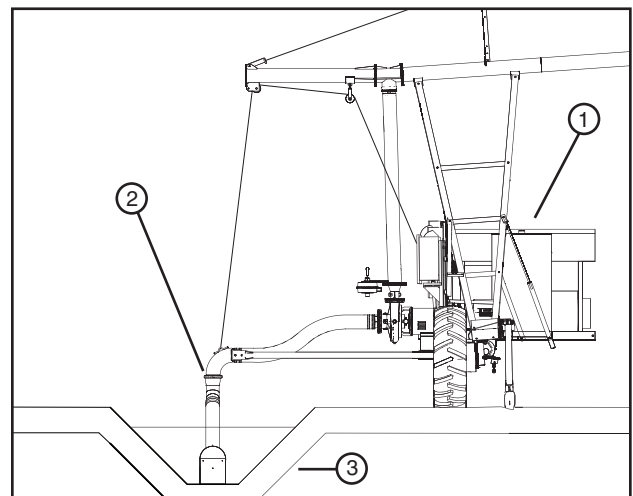

Figure 33-3 1. Engine Generator Setup 3. Ditch  
2. Ditch Suction Inlet

# OPERATION

## Starting and Stopping the Machine

### Starting the Machine

Refer to the control panel owner's manual for information about starting the machine.

### Emergency Stopping

To stop the machine in an emergency situation, shut off any one of the following:

- Main Service Disconnect Switch from public power to the control panel. See figure 34-1.
- Control Panel Main Disconnect Switch. See figure 34-1.
- Any Tower Box Disconnect Switch. See figure 34-1.

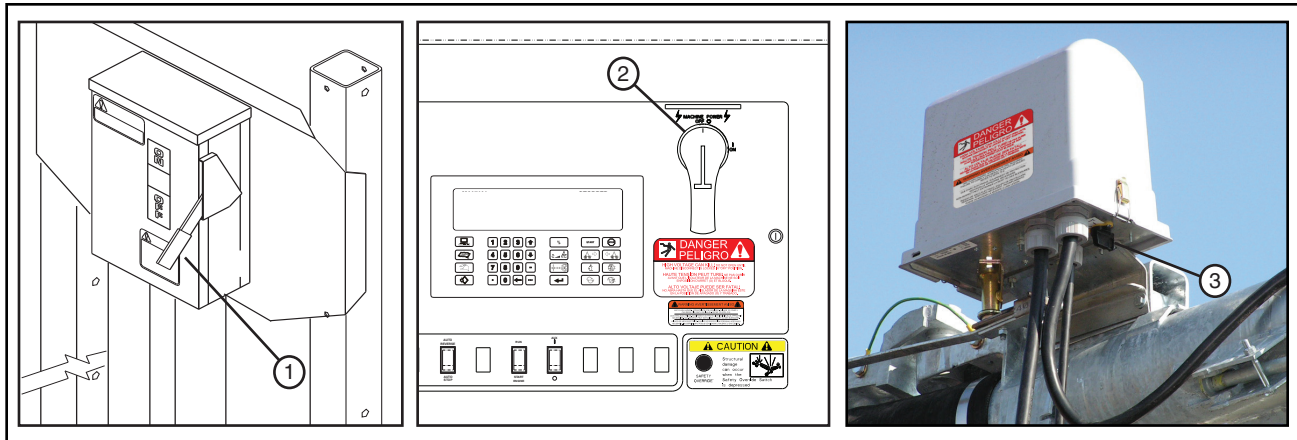

Figure 34-1 1. Main Service Disconnect Switch  
2. Control Panel Main Disconnect Switch  
3. Tower Box Disconnect Switch

### Stopping Under Normal Conditions

1. Press the STOP key. See figure 34-2.
2. Turn the main disconnect switch to the OFF position. See figure 34-2.
3. Turn the pumping unit OFF (if not automatic).
4. If an engine generator set is utilized, place the Engine Run/Start switch to the Start position for the next start-up sequence.

**⚠ WARNING**

- **DO NOT SHUT THE MACHINE OFF BY SLOWLY IDLING DOWN THE ENGINE GENERATOR SET. THIS PRACTICE CAUSES LOW VOLTAGE AND WILL DAMAGE MACHINE COMPONENTS.**
- **ALWAYS STOP THE IRRIGATION MACHINE PRIOR TO SHUTTING DOWN THE ENGINE-GENERATOR SET.**

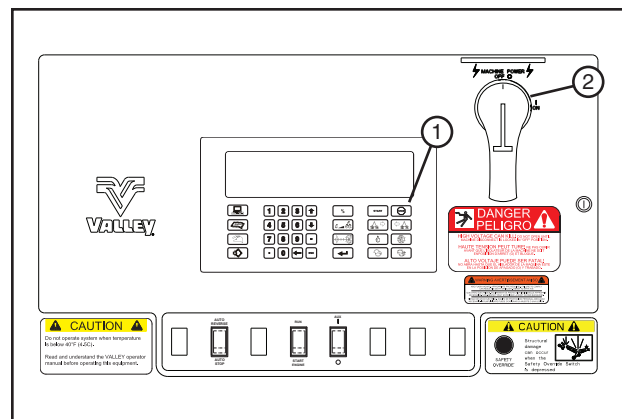

Figure 34-2 AutoPilot Control Panel Shown  
1. Stop Key  
2. Main Disconnect Switch OFF



## Establishing Wheel Tracks

### Wheel Tracks

It is important to establish proper wheel tracks for a linear machine. The methods described in this section will help minimize deep wheel tracks and allow the system to steer as required.

- Wheel tracks affect the linear machine's ability to steer.
- Ensure correct tire pressure to help reduce the possibility of deep wheel tracks.
- Wheel track depths must not exceed 4 in (100 mm). 2 Wheel Linear swing around must not exceed 2 in (50 mm). See figure 35-1.
- Wheel track depth can be controlled by using track fillers, tillers, discs, or flotation tires.

### Direction of Travel

The linear system should typically travel perpendicular to crop rows that are up to 4 in (100 mm) deep. However, if the crop row exceeds 4 in (100 mm) in depth, the direction of travel should be parallel to the crop rows. The linear system should not cross furrows or rows at a shallow angle.

### Establishing Perpendicular Wheel Tracks

Use the following method to establish perpendicular wheel tracks. See figure 35-2.

1. Plant the crop perpendicular to the linear system. See figure 35-2.
2. Make the first pass across the field depending on your tillage method.
  - If using a conservation tillage method, the first pass across the field should be DRY and at a 100% percentage timer setting.
  - If using conventional tillage methods, the first pass across the field should be WET and at a 100% percentage timer setting.
3. The second pass should be at the 80 - 100% percentage timer setting while applying water.
4. Subsequent passes can be at any desired setting. However, for wheel tracks, making frequent light applications of water is better than making fewer heavy applications of water.

Water is not applied the same way as with a side roll, traveling gun, or surface irrigation due to the ease in making applications. Typically application depths would not exceed 1.0 in (25 mm).

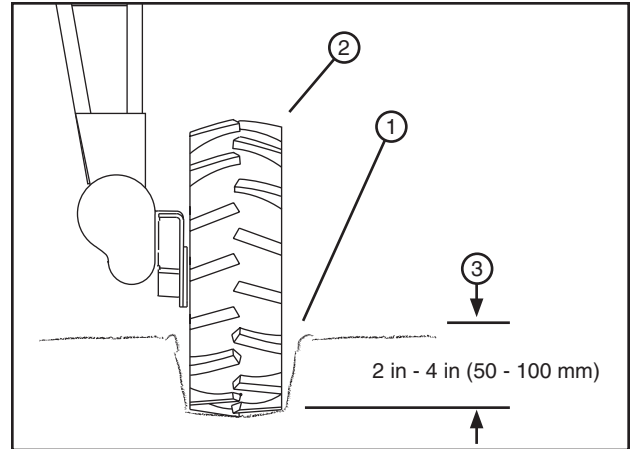

Figure 35-1 1. Wheel track  
2. Linear drive unit  
3. Max Depth

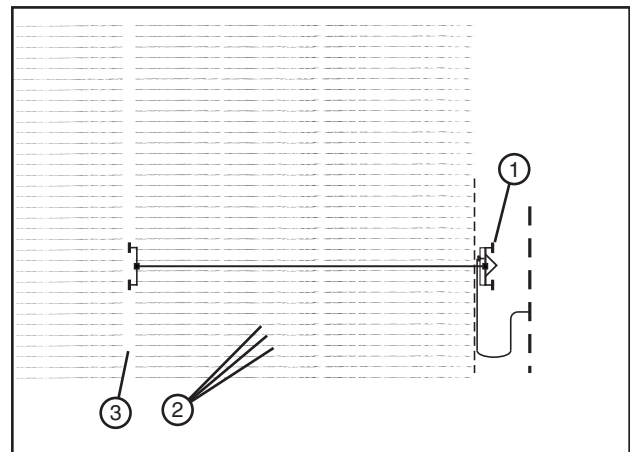

Figure 35-2 Perpendicular Travel  
1. Linear System  
2. Crop Rows  
3. Wheel Track

## NOTE

- Rows must be planted parallel with the wheel tracks and the wheels must not cross a row.

# OPERATION

## Establishing Wheel Tracks

### Establishing Parallel Wheel Tracks

Use one of the following methods to establish parallel wheel tracks:

#### METHOD 1

1. Make the first pass across the field depending on your tillage method.
  - If using a conservation tillage method, the first pass across the field should be DRY and at a 100% percentage timer setting.
  - If using conventional tillage methods, the first pass across the field should be WET and at a 100% percentage timer setting.
2. Plant the crop parallel to the wheel tracks allowing a minimum of 10 in (254 mm) of clearance space between each wheel track and the first crop row on either side of the wheel track. See figures 36-1 and 36-2.

#### METHOD 2

1. Plant the crop parallel to where the irrigation machine will run. See figure 36-1.
2. Make the first pass across the field depending on your tillage method.
  - If using a conservation tillage method, the first pass across the field should be DRY and at a 100% percentage timer setting.
  - If using conventional tillage methods, the first pass across the field should be WET and at a 100% percentage timer setting.
3. Remove or flatten the rows at the wheel tracks with a minimum of 10 in (254 mm) of clearance space on each side of the wheel track. See figure 36-2.

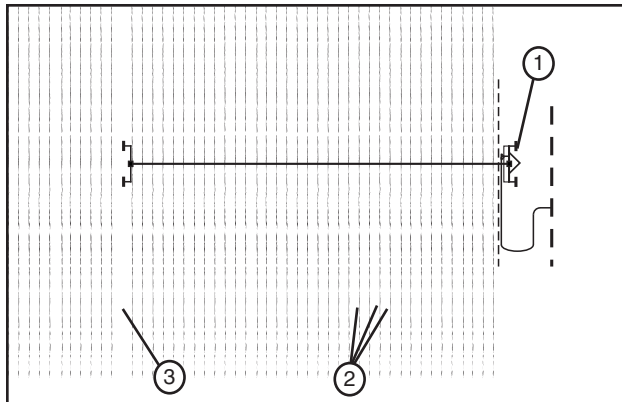

Figure 36-1 Parallel Travel  
1. Linear System  
2. Crop Rows  
3. Wheel Track

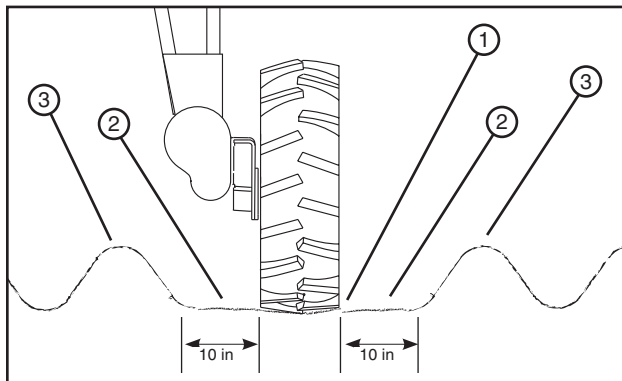

Figure 36-2 1. Wheel Track  
2. Clearance Space  
3. First Crop Row

## Methods Of Operation

The five methods of machine operation that follow are examples of how the machine may be operated. These are not the only methods of operation. Your method of operation may be different.

Contact your authorized Valley dealer for assistance with designing your own method of operation based on management style, soil types, crop water requirements, and system capacity.

### Method I

Can be used on most soil types.

The system operator must be present at the completion of each step to change irrigation mode, percentage timer setting, and/or direction.

1. The percentage timer is set at the desired application rate and the system is started at one end of the field and run wet (irrigating) to the middle of the field. See figure 37-1.
2. The system is stopped, the percentage timer is set to 100% and the system is run dry to the other end of the field. See figure 37-1.

### NOTE

•To reduce the possibility of creating deep ruts, make sure the first part of the field that was irrigated has dried sufficiently before running the system back to the original end of the field.

3. The system direction is reversed, the percentage timer is set to the desired application rate and the system is run wet (irrigating) to the middle of the field. See figure 37-2.
4. The system is stopped, the percentage timer is set to 100% and the system is run dry to the original end of the field. See figure 37-2.

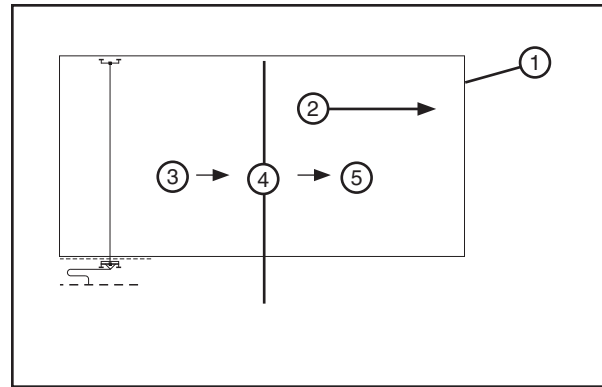

Figure 37-1 1. Field 2. Direction of Travel 3. Wet 4. Stop 5. Dry

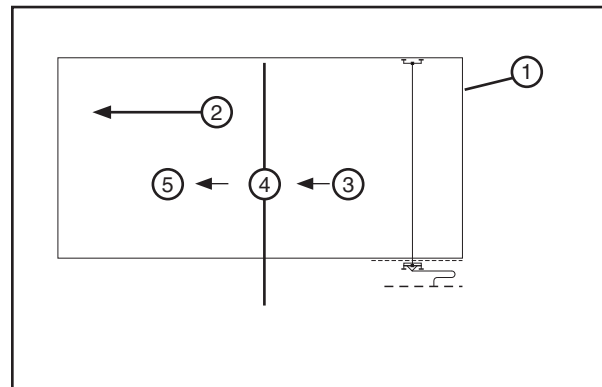

Figure 37-2 1. Field 2. Direction of Travel 3. Wet 4. Stop 5. Dry

# OPERATION

## Methods of Operation

### Method II

Can be used on most soil types.

The system operator does not need to be present at the completion of each step and maintenance can be performed during the system stop.

1. The percentage timer is set at the desired application rate and the system is started at one end of the field and run wet (irrigating) to the other end of the field. See figure 38-1.
2. The system is stopped until the field has dried sufficiently before running the system back to the original end of the field. See figure 38-1.

### NOTE

•To reduce the possibility of creating deep ruts, make sure the field has dried sufficiently before running the system back to the original end of the field.

3. Reverse the system direction, set the percentage timer, and run the system wet or dry back to the original end of the field. See figure 38-2.

### Method III

Can be used for frequent shallow applications on relatively sandy soils.

The system operator may need to be present at the end of the first step if the auto reverse option is not used.

1. The percentage timer is set at the desired application rate and the system is started at one end of the field and run wet (irrigating) to the other end of the field. See figure 38-3.
2. Reverse the system direction, set the percentage timer, and run the system wet back to the original end of the field. See figure 38-4.

### NOTE

•To reduce the possibility of creating deep ruts, the water application should be shallow and the soil type should be sandy.

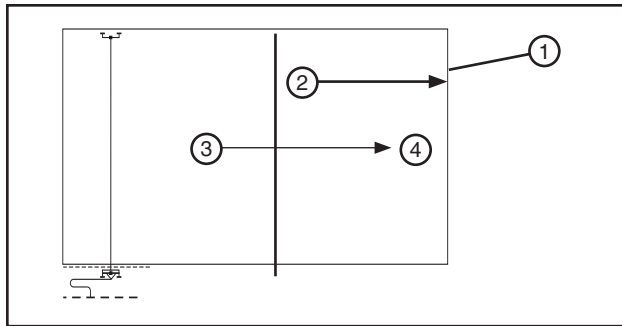

Figure 38-1 1. Field  
2. Direction of Travel  
3. Wet  
4. STOP

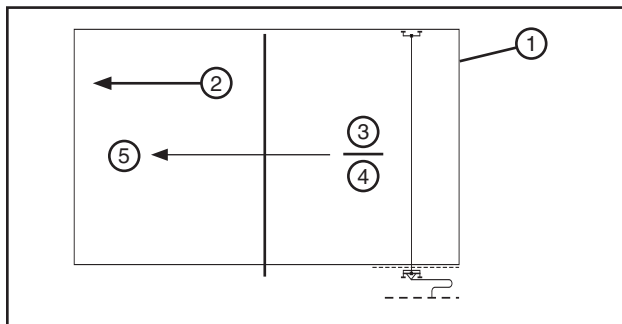

Figure 38-2 1. Field  
2. Direction of Travel  
3. Wet  
4. Dry  
5. STOP

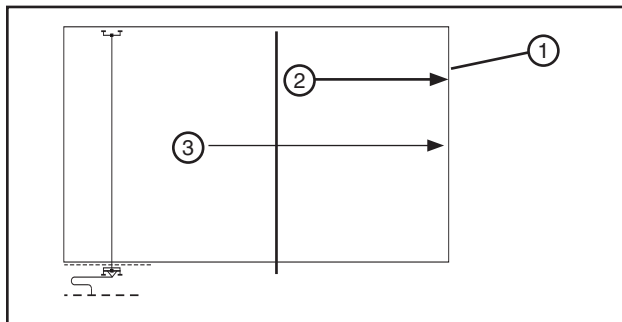

Figure 38-3 1. Field  
2. Direction of Travel  
3. Wet

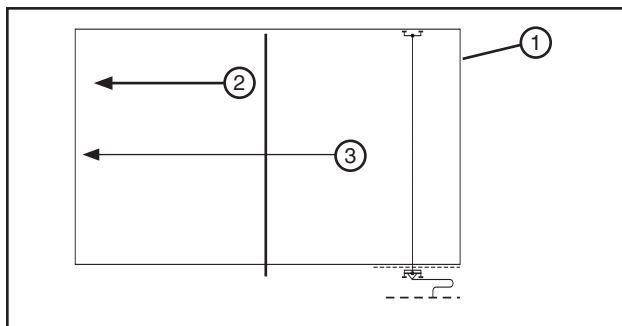

Figure 38-4 1. Field  
2. Direction of Travel  
3. Wet

## Methods of Operation

### Method IV

Can be used in situations where the water source cannot be independently controlled by the system operator.

Requires the system operator to be present at the completion of each step to change the percentage timer setting and/or the direction.

1. The percentage timer is set at the desired application rate, the system is started at one end of the field, and run wet (irrigating) to the middle of the field. See figure 39-1.
2. At the middle of the field the percentage timer is set to 100% and the system continues to run wet to the other end of the field. See figure 39-1.
3. The system direction is reversed, the percentage timer is set to the desired application rate and the system is run wet (irrigating) to the middle of the field. See figure 39-2.
4. At the middle of the field, the percentage timer is set to 100% and the system continues to run wet to the original end of the field. See figure 39-2.

### Method V

Can be used where it is desired to harvest one portion of a field while irrigating another part of the field.

The system operator may need to be present at the end of the first step if the auto reverse option is not used.

1. The percentage timer is set at the desired application rate and the system is started at one end of the field and run wet (irrigating) to the middle of the field and stopped. See figure 39-3.
2. At the middle of the field the system direction is reversed. Set the percentage timer and run the system either wet or dry back to the original end of the field. See figure 39-4.

## NOTE

- To reduce the possibility of creating deep ruts, the water application should be shallow.

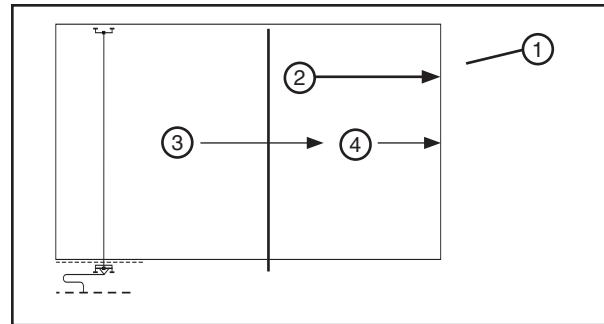

Figure 39-1 1. Field 2. Direction of Travel 3. Wet Deep 4. Wet Shallow

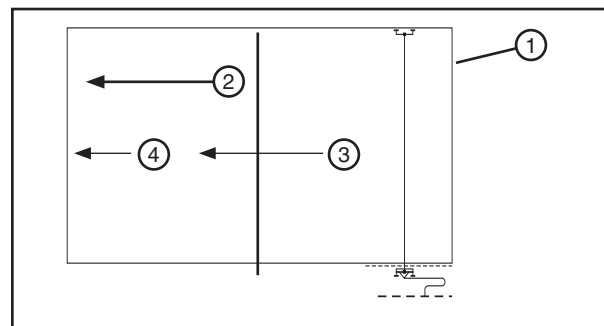

Figure 39-2 1. Field 2. Direction of Travel 3. Wet Deep 4. Wet Shallow

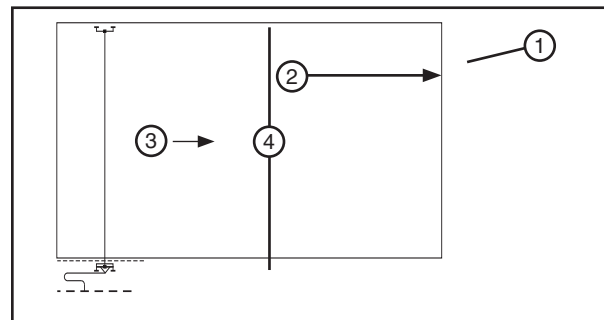

Figure 39-3 1. Field 2. Direction of Travel 3. Wet 4. STOP

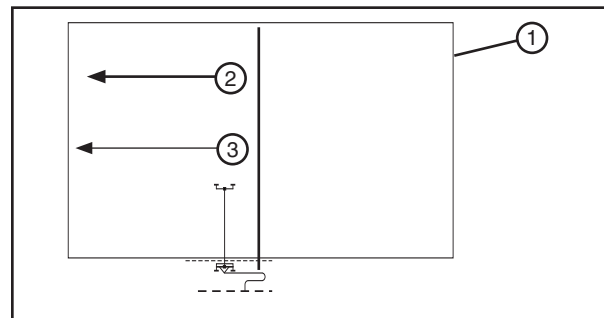

Figure 39-4 1. Field 2. Direction of Travel 3. Wet or Dry

# OPERATION

## Linear Water Application Data

### Wheel Rotation Speeds

Center Drive Output RPM	Standard Tires 11.2 x 24	High Float 14.9 x 24	Maxi-Float 16.9 x 24
29	5.90 ft / min	6.54 ft / min	6.98 ft / min
30	6.10 ft / min	6.77 ft / min	7.22 ft / min
35	7.12 ft / min	7.90 ft / min	8.42 ft / min
37	7.53 ft / min	8.35 ft / min	8.90 ft / min
56	11.39 ft / min	12.63 ft / min	13.48 ft / min
58	11.80 ft / min	13.08 ft / min	13.96 ft / min
68	13.83 ft / min	15.34 ft / min	16.36 ft / min
69	14.03 ft / min	15.56 ft / min	16.60 ft / min

\* Valley Baldor

#### EXAMPLE

$$\begin{aligned} \text{Application/Rate} &= \frac{\text{GPM} \times 2310}{\text{Acres} \times 43560} = \frac{1100 \times 2310}{120 \times 43560} = \frac{2,541,000}{5,227,200} = 0.48 \text{ in / Day} \\ \text{Application/Rate} &= \frac{\text{GPM} \times 2310}{\text{Acres} \times 43560} = \frac{(\quad) \times 2310}{(\quad) \times 43560} = \frac{(\quad)}{(\quad)} = \frac{(\quad)}{\text{Day}} \end{aligned}$$

#### EXAMPLE

$$\begin{aligned} \text{Hours/Pass} &= \frac{\text{Length of Run}}{60 \times \text{Chart Speed}} = \frac{3234\text{ft}}{60 \times 5.90} = 9.1 \text{ hours / Pass} \\ \text{Hours/Pass} &= \frac{\text{Length of Run}}{60 \times \text{Chart Speed}} = \frac{(\quad)}{60 \times (\quad)} = \frac{(\quad)}{(\quad)} \text{ Pass} \end{aligned}$$

NOTE: Add maintenance, refueling, and other "down time" to the calculated results.

#### EXAMPLE

$$\begin{aligned} \text{Inches/Pass} &= \frac{\text{Hrs./Pass} \times \text{App. Rate (In./Day)}}{24} = \frac{9.1 \times 0.48}{24} = 0.18 \text{ in / Pass} \\ \text{Inches/Pass} &= \frac{\text{Hrs./Pass} \times \text{App. Rate (In./Day)}}{24} = \frac{(\quad)}{24} = \frac{(\quad)}{\text{Pass}} \end{aligned}$$

### Percentage Timer Settings

Hrs./Pass			Inches/Pass		
100%	@ 100%	Hrs /Pass	100%	@ 100%	in /Pass
90%	_____ ÷ 0.90 =	_____	90%	_____ ÷ 0.90 =	_____
80%	_____ ÷ 0.80 =	_____	80%	_____ ÷ 0.80 =	_____
70%	_____ ÷ 0.70 =	_____	70%	_____ ÷ 0.70 =	_____
60%	_____ ÷ 0.60 =	_____	60%	_____ ÷ 0.60 =	_____
50%	_____ ÷ 0.50 =	_____	50%	_____ ÷ 0.50 =	_____
40%	_____ ÷ 0.40 =	_____	40%	_____ ÷ 0.40 =	_____
30%	_____ ÷ 0.30 =	_____	30%	_____ ÷ 0.30 =	_____
25%	_____ ÷ 0.25 =	_____	25%	_____ ÷ 0.25 =	_____
20%	_____ ÷ 0.20 =	_____	20%	_____ ÷ 0.20 =	_____
15%	_____ ÷ 0.15 =	_____	15%	_____ ÷ 0.15 =	_____
10%	_____ ÷ 0.10 =	_____	10%	_____ ÷ 0.10 =	_____
5%	_____ ÷ 0.05 =	_____	5%	_____ ÷ 0.05 =	_____

### Electric Cord Handling

#### **DANGER**

- NEVER HANDLE THE ELECTRIC CORD WHEN THE POWER IS ON.
- THE DISCONNECT SWITCH MUST BE IN THE “OFF” POSITION WHEN INSERTING OR REMOVING THE PLUG FROM THE RECEPTACLE.
- NEVER ALLOW THE ELECTRIC CORD TO KINK.
- NEVER ALLOW THE HOSE TO DRAG OVER THE ELECTRIC CORD ALWAYS LAY THE ELECTRIC CORD OVER THE HOSE.
- REGULARLY INSPECT THE ELECTRIC CORD FOR NICKS OR CUTS. REPLACE A DAMAGED ELECTRIC CORD IMMEDIATELY. DO NOT ATTEMPT TO SPLICE A DAMAGED ELECTRIC CORD.

#### **WARNING**

- DO NOT DRIVE ANY VEHICLE OVER THE CORD AT ANY TIME UNLESS THE CORD IS PROTECTED FROM PHYSICAL DAMAGE.
- REMOVE ALL SHARP OBJECTS FROM THE TRAVEL LANE THAT MAY CAUSE DAMAGE TO THE ELECTRIC CORD.
- ALWAYS INSURE THAT THE ELECTRIC CORD MECHANICAL SAFETY CABLE IS ROUTED THROUGH CABLE HOOK ON POWER PEDESTAL EACH TIME THE ELECTRIC CORD IS PLUGGED INTO THE RECEPTACLE.
- INSURE THAT THE MECHANICAL SAFETY CABLE IS FUNCTIONAL EACH TIME THE ELECTRIC CORD IS PLUGGED INTO POWER PEDESTAL. THE PLUG MUST ALWAYS BE FREE SO THAT THE MECHANICAL SAFETY CABLE CAN PULL THE PLUG FROM RECEPTACLE IF NECESSARY.
- ALWAYS ATTACH THE CAP TO PLUG WHEN MOVING THE ELECTRIC CORD AND PLUG FROM ONE POWER PEDESTAL TO ANOTHER, OR WHEN STORING THE CORD.
- THE PLUG CAP COLLAR IS FOR ATTACHMENT OF THE PLUG CAP ONLY! DO NOT ATTACH THE PLUG CAP COLLAR TO THE RECEPTACLE. THE PLUG MUST ALWAYS BE FREE SO THAT THE MECHANICAL SAFETY CABLE CAN PULL THE PLUG FROM RECEPTACLE IF NECESSARY.

### Electric Cord Operation

1. Ensure that the danger signs are in place and visible at each end of the travel lane. See figure 41-1.
2. Check the electric cord for nicks, cuts, or abrasions. DO NOT use the electric cord or start the system if any of these defects are found. Contact your local Valley dealer.

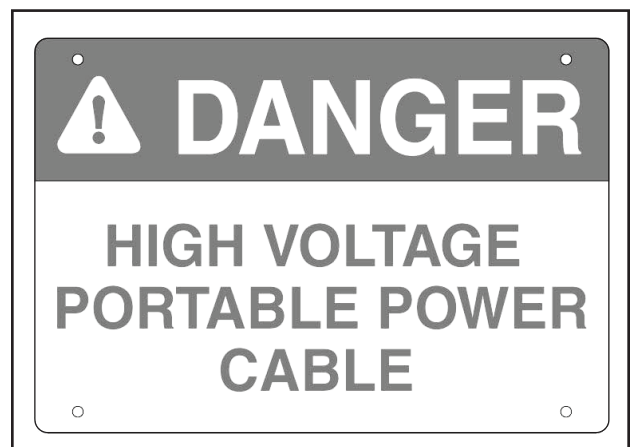

Figure 41-1 Danger Sign



# OPERATION

## Closed Delivery Electric Cord Operation

- Turn the power pedestal disconnect switch to the OFF position. See figure 42-1.

### **⚠ DANGER**

•THE DISCONNECT SWITCH MUST BE IN THE “OFF” POSITION WHEN INSERTING OR REMOVING THE PLUG FROM THE RECEPTACLE.

- Remove plug cap from electric cord plug, and insert the electric cord plug into the power pedestal receptacle. See figure 42-1.

### **⚠ WARNING**

•ALWAYS ATTACH THE PLUG CAP TO THE PLUG WHEN MOVING THE ELECTRIC CORD FROM ONE POWER PEDESTAL TO ANOTHER OR WHEN STORING THE ELECTRIC CORD.

- Place the cord anchor cable through the mechanical cable anchor ring on the power pedestal.

For proper operation of the cord anchor cable disconnect, there must be slack in the electric cord between the cord grip and plug when the cord anchor cable is pulled taut. See figure 42-2.

### **⚠ WARNING**

•DO NOT ATTACH ELECTRIC CORD PLUG TO POWER PEDESTAL RECEPTACLE WITH PLUG CAP COLLAR.

- Turn the power pedestal disconnect switch to the ON position to energize the cart disconnect panel.

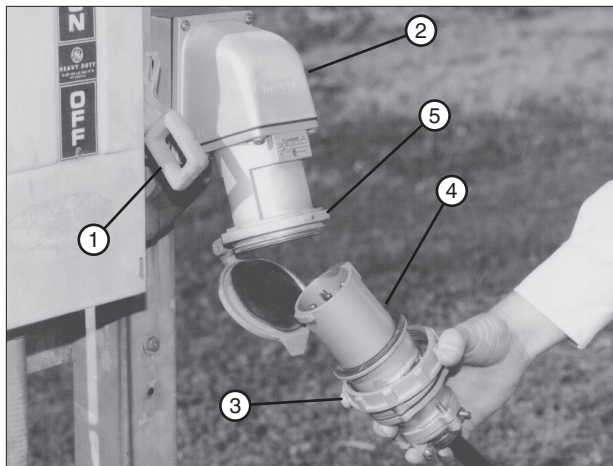

Figure 42-1 1. Disconnect Switch 2. Power Pedestal 3. Plug Cap Collar 4. Plug 5. Receptacle

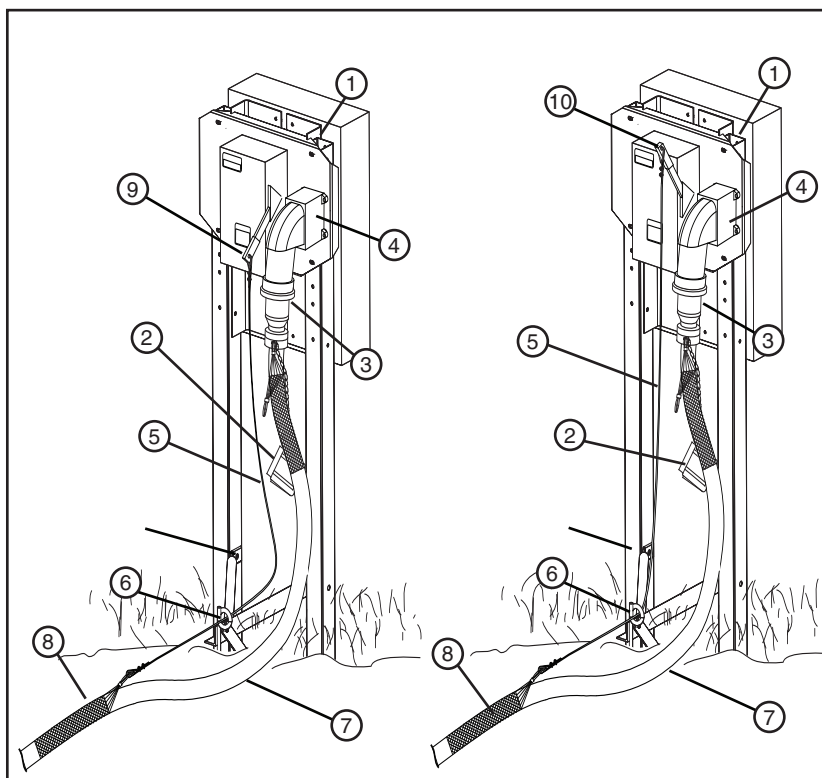

Figure 42-2 1. Power Pedestal 2. Plug Cap 3. Electric Cord Plug 4. Power Pedestal Receptacle 5. Cord Anchor Cable 6. Cable Anchor Ring 7. Electric Cord 8. Cord Grip 9. Disconnect Switch- OFF 10. Disconnect Switch - ON



# OPERATION

## Closed Delivery

### Poly Hose

The standard poly hose wall thickness varies depending on which inlet the hose is used on and the size of hose. See figure 47-1.

A heavier wall SDR 11 – 6 in poly hose is used with the swivel inlet because of the tighter bending radius of the hose and the stresses of auto reversing.

### Moving Poly Hose

Use a 5 ft (1.5 m) nylon sling as shown when moving poly hose. See figure 43-2.

### Cart Path

The cart path must be maintained in a smooth, hard condition to allow the poly hose to slide freely over the surface.

### Hose Bumpers

The installation of hose bumpers on the cart can reduce the hose handling labor, but may require heavier wall SDR 13.5 or SDR 11 poly hose due to the tighter bending radius of the hose. See figure 43-3.

Inlet	Size	Wall Thickness
Swivel Inlet	4.75 in	SDR 17
	6 in	SDR 11
Swing Around Inlet	6 in	SDR 17

Figure 43-1

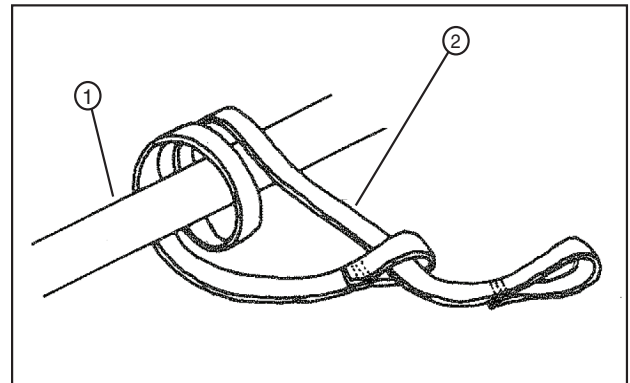

Figure 43-2 1. Poly Hose  
2. Sling

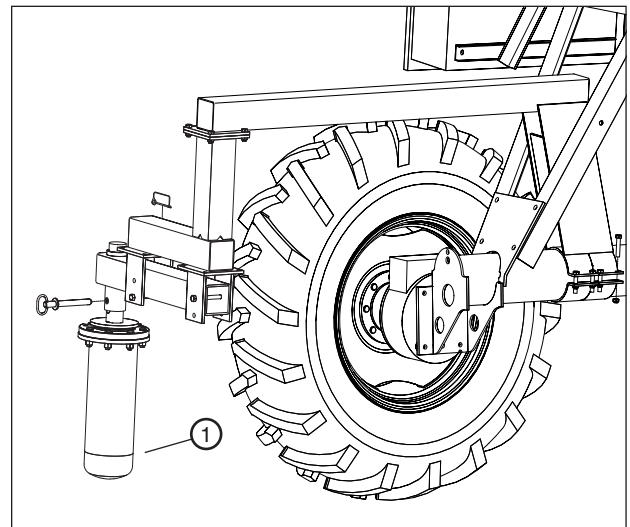

Figure 43-3 1. Hose Bumper

# OPERATION

## Closed Delivery Hose Inlets and Couplers

There are two different hose inlets, the Swivel Inlet and the Swing-Around Inlet.

- Swivel Inlet hose layout and basic method of operation begins on the next page.
- Swing Around hose layout and basic method of operation begins on page 61.
- Hose coupler design varies depending on the type and size of the hose. See figure 44-1 and 44-2.
- Swivel inlet hose couplers are secured to the inlet with pull straps. See figure 44-1.

## Swing-Around Inlet and Couplers Option

- Swing-Around Tee Inlet hose couplers are secured to the inlet with a circle lock ring. See figure 44-2.
- Soft hose requires the use of chains to pull the poly hose. See figure 44-2.
- The Swing-Around Tee Inlet uses soft hose on the inlet end of the hose. See figure 44-2.

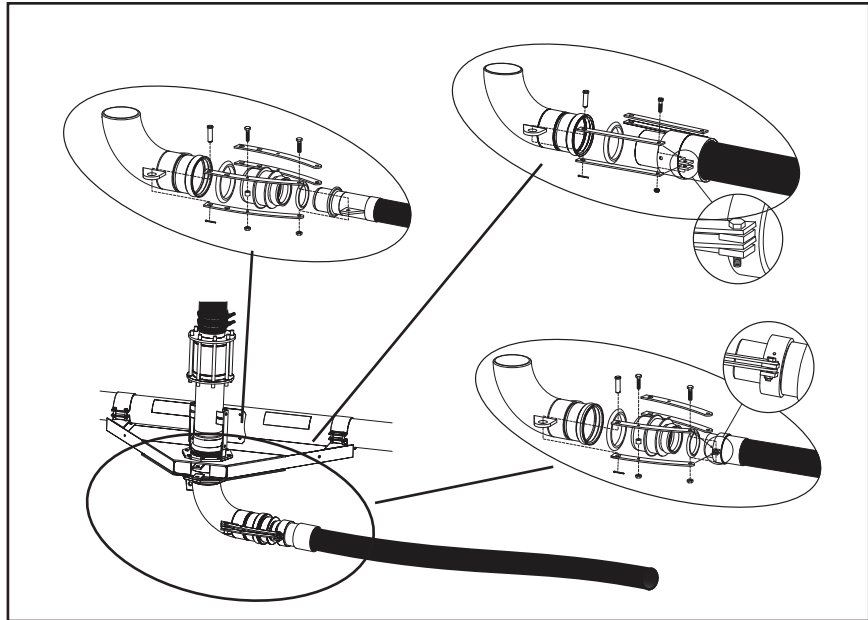

Figure 44-1 Swivel Inlet Hose Couplers

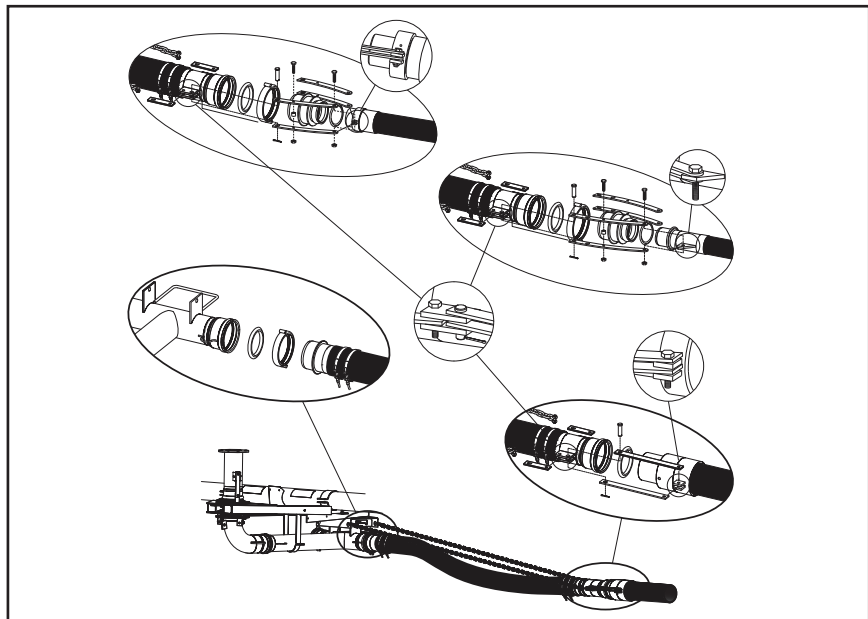

Figure 44-2 Swing-Around Tee Inlet Hose Couplers, Soft hose and Chains

### Hose and Cord Positioning Guidelines

When using the swivel inlet, position the hose and cord as shown. See figure 45-1.

- The hose layout distance from the water pipeline varies depending on hose diameter.
- The cart path must be maintained in a smooth, hard condition, to allow the poly hose to slide freely over the surface.
- The swivel inlet hose drag is designed to reverse at the ends of the field without disconnecting the poly hose from the cart.
- The hard hose is attached directly to the swivel inlet without a soft hose connection
- The Machine can not be reversed when the poly hose is connected to the swing around tee inlet. The hose must be manually disconnected and re-attached to the opposite side before reversing. A soft hose connection is required when using the tee inlet. DO NOT attach the hard hose directly to the tee inlet.
- The swivel elbow should be adjusted outward to an angle of at least 10° in order for the machine to reverse consistently.
- Due to the tight bending radius in the poly hose, and the stresses of auto-reversing, it is recommended to use heavier (SDR 15.5 or SDR 13.5) wall poly hose for swivel inlet hose drags.
- Hose bumpers may be installed to push the poly hose away from the cart tires.
- At the ends of the field, where reversing direction takes place, maintain a smooth, hard area on the inlet side of the cart, so that the poly hose can slide freely over the surface when reversing.
- With the linear cart at the edge of the field, position the entire length of the first hose, depending on hose diameter. Place the hose in line with or slightly outside of the swivel elbow. After the first pass the hose will be positioned properly and does not need to be moved again. See figures 45-1.

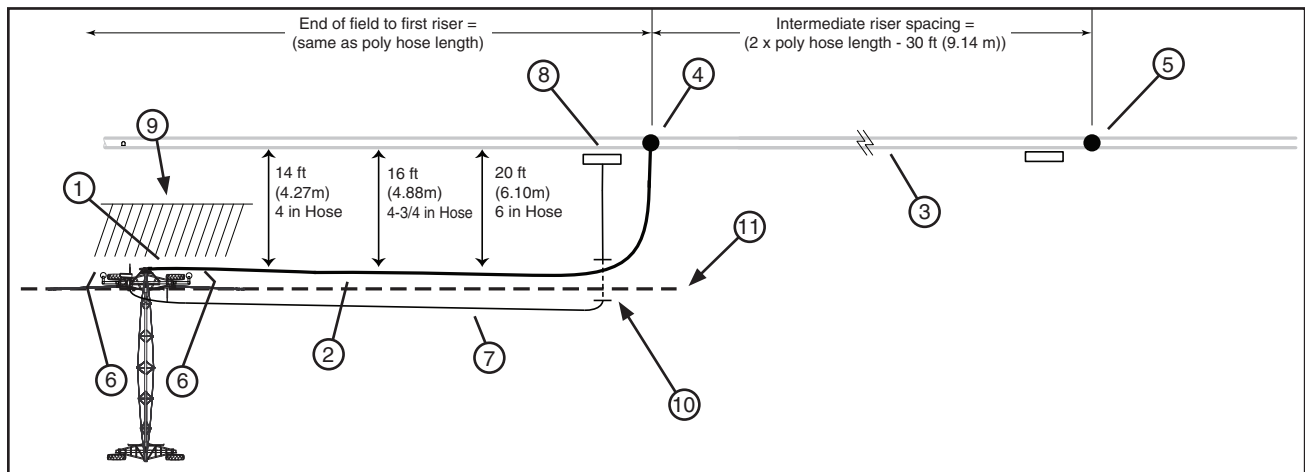

Figure 45-1 Side Inlet Hose Layout

- |                   |                             |                     |
|-------------------|-----------------------------|---------------------|
| 1. Swivel Inlet   | 5. Intermediate Riser       | 9. Smooth Hard Area |
| 2. Hose           | 6. Hose Bumper (optional)   | 10. Buried Cable    |
| 3. Water Pipeline | 7. Electric Cord (optional) | 11. Guidance Furrow |
| 4. First Riser    | 8. Power Pedestal           |                     |

# OPERATION

## Closed Delivery

### Hose and Cord Positioning (continued)

There are two different hose inlets, the Elbow Inlet and the Tee Inlet.

- The Elbow Inlet is used on both the standard and swing around 2 wheel linear carts.
- The Tee Inlet is available only on swing around 2 wheel linear carts. On swing around 2 wheel linear, the inlet position in relationship to the water pipeline determines which inlet to use. Always use the inlet that is closest to the water pipeline.

#### Swivel Inlet

- When using the swivel inlet, position the hard hose directly to the swivel as shown. See figure 46-1.
- If using the optional electric cord drag with the hose connected to the swivel inlet. Prevent interference between the electric cord and hose by burying the electric cord under the hose and cart path. See figure 46-1

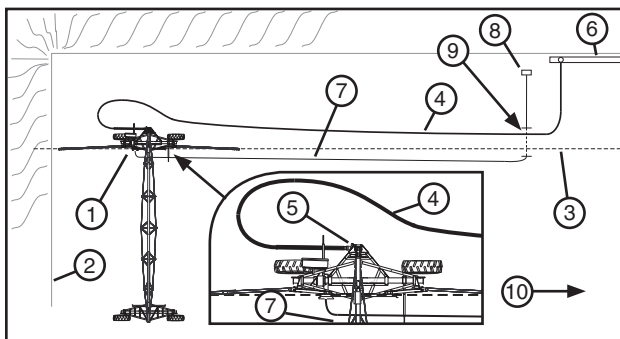
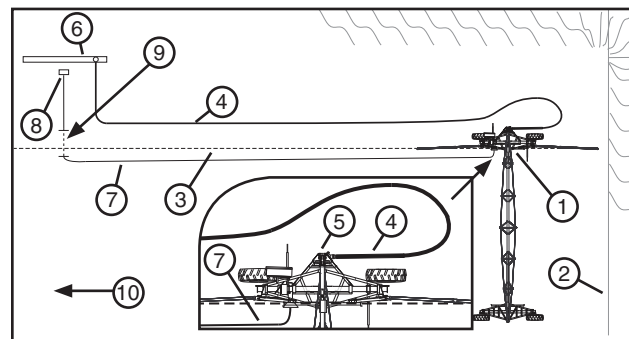

Figure 46-1 1. Linear Cart  
2. Edge Of Field  
3. Furrow  
4. Hose  
5. Swivel Inlet  
6. Pipeline



7. Electric Cord  
8. Power Pedestal  
9. Buried Cable  
10. Direction of Travel

### Tee Inlet (Swing Around)

- When using the tee inlet, position the hose as shown. See figure 46-2.
- The tee inlet requires the use of a soft hose connection to the machine, with chains to pull the hose. DO NOT attach the hard hose directly to the tee inlet.
- If using the optional electric cord drag with the tee inlet, position the electric cord far enough away from the hose and furrow guidance skid, so that the hose or furrow guidance skid will not drag over it. When applicable, prevent interference between the electric cord and hose by positioning the electric cord over the top of hose. See figure 46-2.

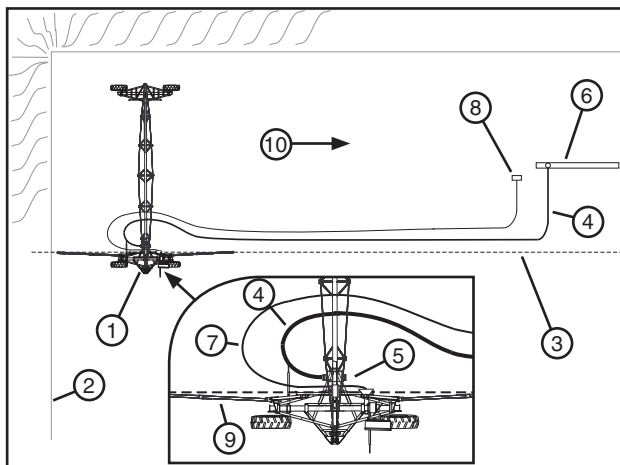
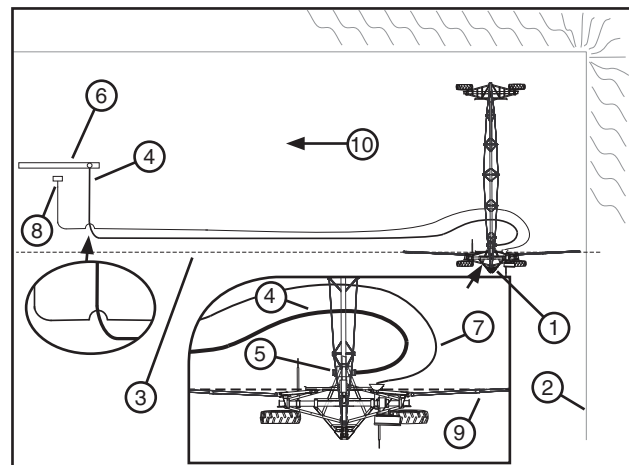

Figure 46-2 1. Linear Cart  
2. Edge Of Field  
3. Furrow  
4. Hose  
5. Tee Inlet  
6. Pipeline



7. Electric Cord  
8. Power Pedestal  
9. Furrow Guidance Skid  
10. Direction of Travel

## Closed Delivery

### Standard Linear Manual Method

The following instructions describe a method of hose and cord positioning which includes how to position the hose and optional electric cord based on:

- Positioning the swivel inlet manually so it will be in the operating position as the machine moves away from the end of the field.
  - Position of the machine in relationship to the pipeline and power pedestals.
  - Position and direction as machine moves across the field.
1. Connect the first hose to the pipeline shut off valve and linear cart swivel inlet, then latch in place. See figure 47-1.
    - Temporarily installing a post approximately 6 ft (1.82 M) behind the linear cart and on the pipeline side, the post will aid in connecting the polyethylene hose to the linear cart inlet. See figure 47-1.
  2. Set the end of field/hose stop post for the length of the first hose being used.
  3. If using the optional electric cord drag:
    - (a) Position the electric cord far enough away from the hose, so that the hose will not drag over it. To prevent interference between the electric cord, cart tires, furrow guidance system and hose, bury the electric cord in the area where interference will occur or when applicable, position the electrical cord over the top of the hose. See figure 47-1.
    - (b) Make sure the first power pedestal disconnect is in the OFF position.
    - (c) Connect the electric cord to the first power pedestal.
    - (d) When ready, switch the first power pedestal disconnect switch into the ON position.
  4. At the control panel:
    - (a) Set the direction of travel.
    - (b) Set the percentage timer to the desired application rate.
  5. When ready, start the machine and open the water shut off valve for the first hose. The machine should start and run in the desired direction and stop at the end of field/hose stop post which was set for the length of the first hose.

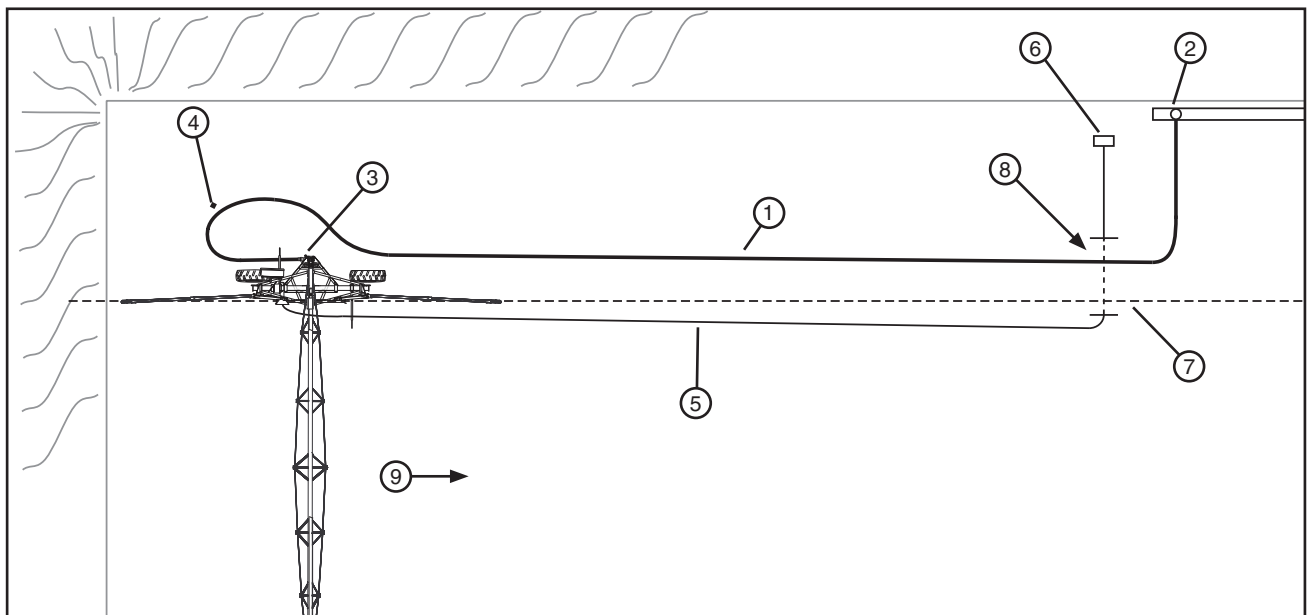

Figure 47-1 1. First Hose 3. Swivel Inlet 5. Electric Cord 7. Furrow Guidance 9. Direction of Travel  
2. Shut Off Valve 4. Temporary Post (optional) 6. Power Pedestal 8. Buried Cable

# OPERATION

## Closed Delivery Standard Linear Manual Method (continued)

6. When the machine stops at the end of field/hose stop post, Close the water shut off valve for the first hose. See figure 48-1.

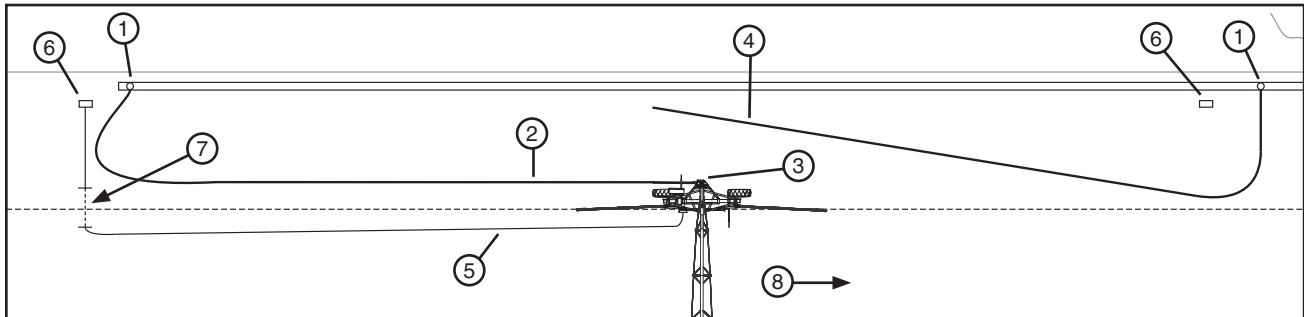

Figure 48-1 1. Shut Off Valve 2. First Hose 3. Swivel Inlet 4. Second hose 5. Electric Cord 6. Power Pedestal 7. Buried Cable 8. Direction of Travel

7. Unlatch and disconnect first hose from swivel inlet. Positioning the hose to drain away from the cart path. See figure 48-2.
8. With second hose connected to shut off valve, position second hose, connect to swivel inlet and latch in place. Reposition the end of field/hose stop for the length of the second hose being used. See figure 48-2.
9. If using the optional electric cord drag:
- Make sure the first power pedestal disconnect is in the OFF position.
  - Disconnect the electric cord from the first power pedestal.
  - Position the electric cord as shown. When applicable, prevent interference between the electric cord and the hose by burying the electric cord in the ground as shown. Allowing for the hose to travel over the buried portion of the cord. See figure 48-2.
  - Make sure the second power pedestal disconnect is in the OFF position.
  - Connect the electric cord to the second power pedestal.
  - When ready, switch the second power pedestal disconnect switch into the ON position.
10. At the control panel:
- Select the original direction of travel.
  - Set the percentage timer to the desired application rate.
11. When ready, start the machine and open the water shut off valve for the second hose.. The machine should start and run in the original direction and stop at the end of field/hose stop post which was set for the length of the second hose.
12. Repeat the steps 6-11 as needed to cross the field in the same direction.

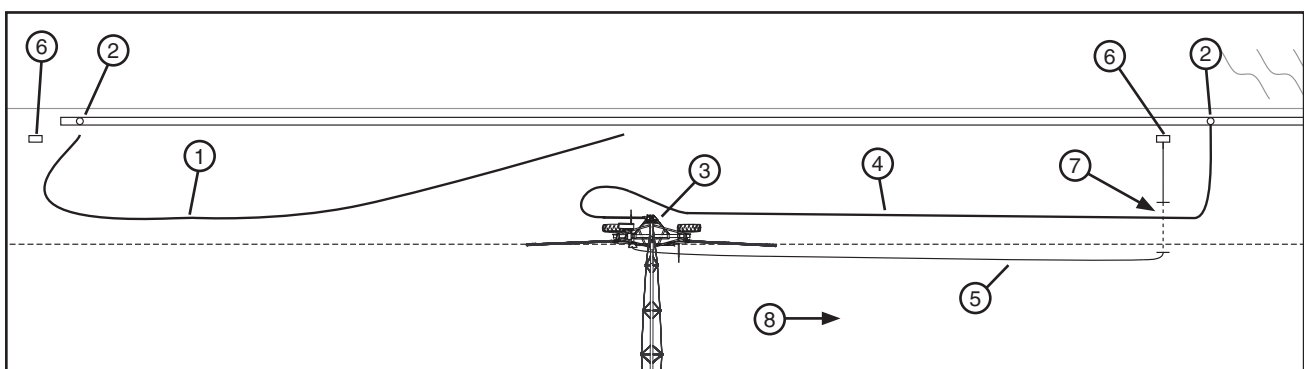

Figure 48-2 1. First Hose 2. Shut Off Valve 3. Swivel Inlet 4. Second hose 5. Electric Cord 6. Power Pedestal 7. Buried Cable Location 8. Direction of Travel

# OPERATION

## Closed Delivery

### Standard Linear Manual Method (continued)

13. When the machine approaches the edge of the field it will contact the end of field/hose stop switch and auto stop, or auto reverse.
14. When the machine stops at the end of the field/hose stop post, Close the water shut off valve fro the hose.
15. Reposition the end of field/hose stop for the length of hose being used.
16. At the control panel:
  - (a) Select desired direction of travel.
  - (b) Set the percentage timer to the desired application rate.
17. When ready, start the machine and open the water shut off valve for the hose. The machine should start and run in the opposite direction and stop at the end of field/hose stop post which was set for the length of the hose.

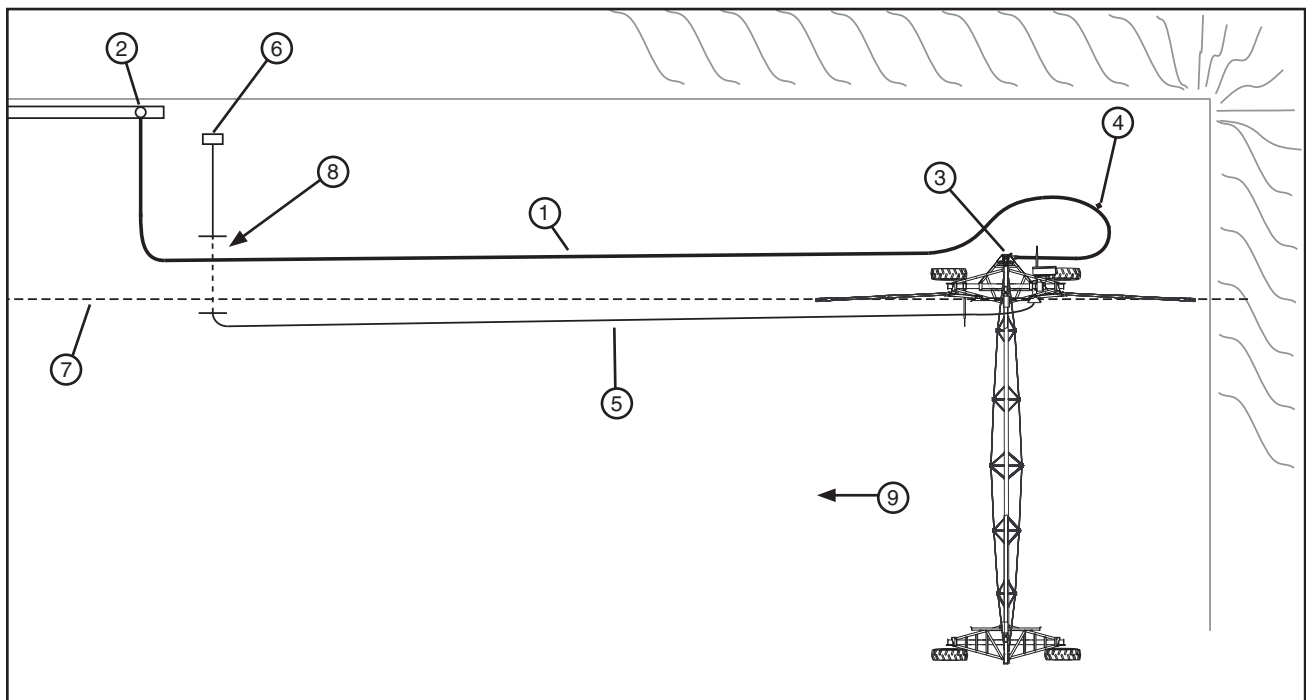

Figure 49-1 1. Hose 3. Swivel Inlet 5. Electric Cable 7. Furrow Guidance 9. Direction of Travel  
2. Shut Off Valve 4. Stop post 6. Power Pedestal 8. Buried Cable Location



# OPERATION

## Closed Delivery Standard Linear Manual Method (continued)

18. When the machine reaches the end of field/hose stop. Close the water shut off valve for the first hose. See figure 50-1.

19. With second hose connected to shut off valve, position second hose, unlatch and disconnect first hose from swivel inlet. Positioning the hose to drain away from the cart path. See figure 50-2.

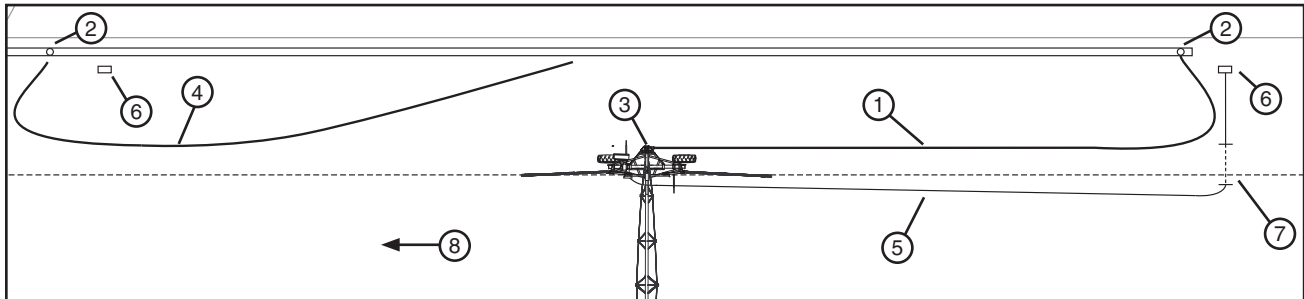

Figure 50-1 1. First Hose 4. Second Hose 7. Buried Power Cable  
2. Shut Off Valve 5. Electric Cord 8. Direction of Travel  
3. Swivel Inlet 6. Power Pedestal

20. Reposition the end of field/hose stop for the length of the second hose being used. Connect the second hose to swivel inlet and latch in place.

21. If using the optional electric cord drag:

- (a) Make sure the first power pedestal disconnect is in the OFF position.
- (b) Disconnect the electric cord from the first power pedestal.
- (c) Position the electric cord as shown. When applicable, prevent interference between the electric cord and the hose by burying the electric cord in the ground as shown. Allowing for the hose to travel over the buried portion of the cord. See figure 50-2.
- (d) Make sure the second power pedestal disconnect is in the OFF position.
- (e) Connect the electric cord to the second power pedestal.
- (f) When ready, switch the second power pedestal disconnect switch into the ON position.

22. When ready, start the machine and open the water shut off valve for the second hose

23. Repeat the steps 16-22 as needed to cross the field in the same direction.

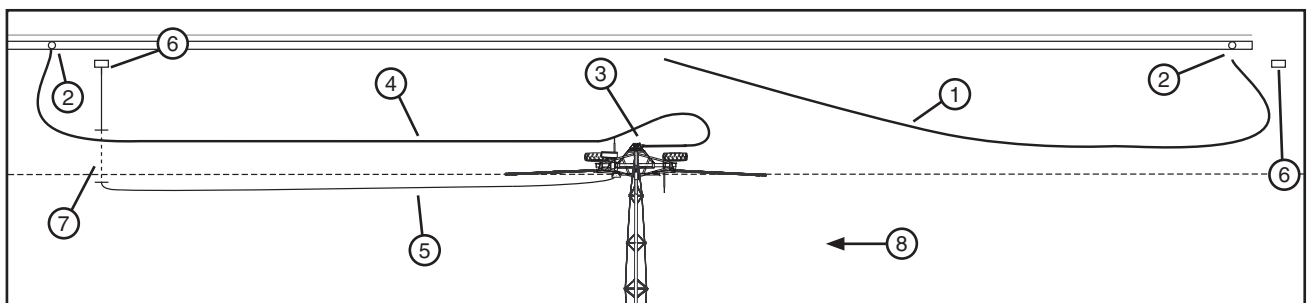

Figure 50-2 1. First Hose 4. Second Hose 7. Buried Power Cable Location  
2. Shut Off Valve 5. Electric Cord 8. Direction of Travel  
3. Swivel Inlet 6. Power Pedestal

## Closed Delivery

### Standard Linear Auto Reverse

The following instructions describe a method of hose and cord positioning which includes how to position the hose and optional electric cord based on:

- Positioning the swivel inlet so it will automatically pivot into the operating position as the machine moves away the end of the field.
- Position of machine in relationship to the pipeline and power pedestals.
- Position and direction as machine moves across the field.

1. Connect the first hose to the pipeline shut off valve and linear cart swivel inlet, then latch in place. See figure 51-1.
2. Set the end of field/hose stop post for the length of the hose being used.
3. If using the optional electric cord drag:

- (a) Make sure the power pedestal disconnect is in the OFF position.
- (b) Position the electric cord far enough away from the hose, so that the hose will not drag over it. To prevent interference between the electric cord, cart tires and hose, bury the electric cord in the area where interference will occur or when applicable, position the electric cord over the top of hose. See figure 51-1.
- (c) Connect the electric cord to the power pedestal.
- (d) When ready, switch the power pedestal disconnect switch into the ON position.

4. At the machine/control panel:
  - (a) Set the direction of travel.
  - (b) Set the percentage timer to the desired application rate or speed.
  - (c) If applicable set the Auto Reverse/Auto Stop control as desired.
5. When ready, start the machine. If applicable, start pipeline pump and open the water shut off valve for the hose. The machine should start and run in the desired direction and auto reverse or stop at the end of field/hose stop post which was set for the length of the hose.

- (a) As the cart moves, the swivel inlet begins to pivot. See figure 51-2.
- (b) As the swivel inlet pivots the hose is pushed out away from the cart and guided by either the side walls of the cart tires or the optional hose bumpers. See figure 51-3.
- (c) After the swivel inlet has pivoted completely the hose is being pulled by the swivel inlet and guided by either the side walls of the cart tires or the optional hose bumpers. See figure 51-4.

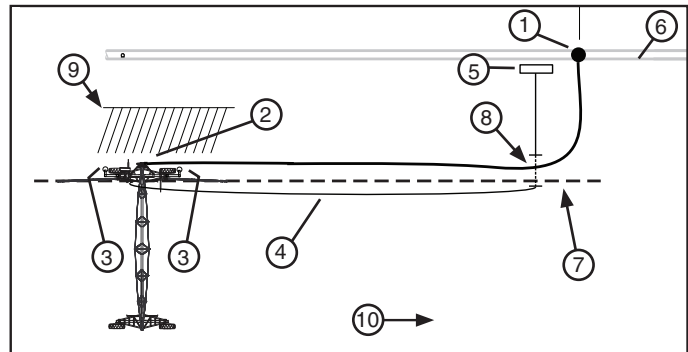

Figure 51-1 1. Shut Off Valve 6. Alternate Power Pedestal and Electric Cord Position  
 2. Swivel Inlet 7. Guidance Furrow  
 3. Hose Bumper (optional) 8. Buried Cable  
 4. Electric Cord (optional) 9. Smooth Hard Packed Area  
 5. Power Pedestal 10. Direction of Travel

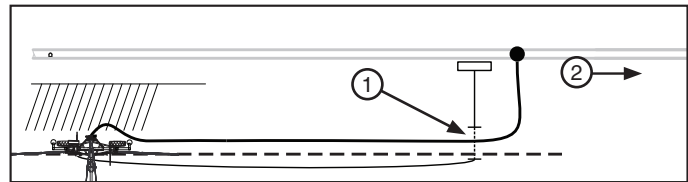

Figure 51-2 1. Buried Cable  
 2. Direction of Travel

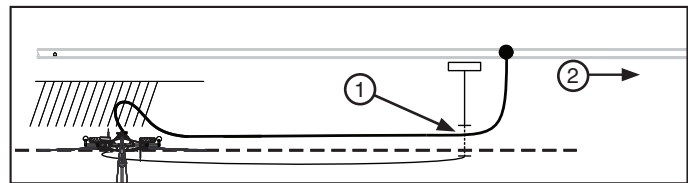

Figure 51-3 1. Buried Cable  
 2. Direction of Travel

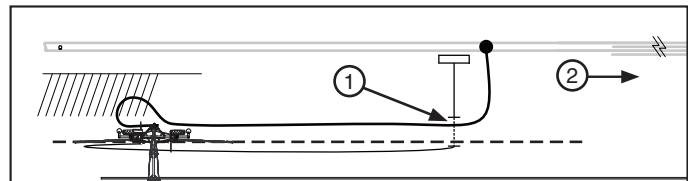

Figure 51-4 1. Buried Cable  
 2. Direction of Travel

# OPERATION

## Closed Delivery

### Standard Linear Auto Reverse (continued)

6. As the machine approaches the end of field/hose stop post, Stop the machine and close the water shut off valve for the hose.
7. Disconnect the first hose from the pipeline shut off valve so that water from the hose drains away from the cart path.
  - If more than one hose is being used, disconnect first hose from swivel inlet. Connect second hose to next pipeline shut off valve, position second hose, connect and secure to swivel inlet. See figure 52-1.
  - If only one hose is being used, reposition the hose and connect to the next pipeline shutoff valve.
8. Reposition the end of field/hose stop for the length of the hose being used.
9. If using the optional electric cord drag:
  - (a) Make sure the power pedestal disconnect is in the OFF position.
  - (b) Disconnect the electric cord from the power pedestal.
  - (c) Position the electric cord far enough away from the hose, so that the hose will not drag over it. To prevent interference between the electric cord, cart tires, furrow guidance system and hose, bury the electric cord in the area where interference will occur or when applicable, position the electric cord over the top of hose. See figure 52-1.
  - (d) Make sure the second power pedestal disconnect is in the OFF position.
  - (e) Connect the electric cord to the second power pedestal.
  - (f) When ready, switch the second power pedestal disconnect switch into the ON position.
10. At the machine/control panel:
  - (a) Select the original direction of travel.
  - (b) Set the percentage timer to the desired application rate or speed.
  - (c) If applicable set the Auto Reverse/Auto Stop control as desired.
11. When ready, start the machine. If applicable, start pipeline pump and open the water shut off valve for the hose. The machine should start and run in the desired direction and auto reverse or stop at the end of field/hose stop post which was set for the length of the hose.
12. Repeat the steps 6-11 as needed to cross the field.

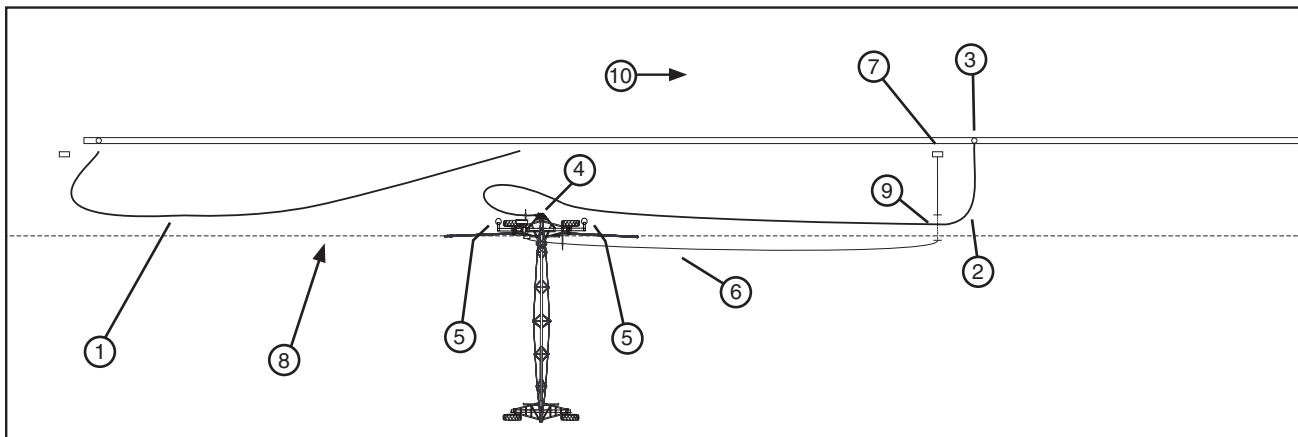

Figure 52-1 1. First Hose 4. Swivel Inlet 7. Power Pedestal 10. Direction of Travel  
2. Second Hose 5. Hose Bumper (optional) 8. Guidance Furrow  
3. Shut Off Valve 6. Electric Cord (optional) 9. Buried Cable Under Path

## Closed Delivery

### Standard Linear Auto Reverse (continued)

13. As the machine approaches the edge of the field do one of the following:
- **If Auto Reverse is on**, monitor and assist the auto reverse process as needed, shutting pipeline valve for the hose off and on as required.
    - (a) Reposition the end of field/hose stop for the length of hose being used.
    - (b) The machine should start and run in the desired direction and stop at the end of field/hose stop post which was set for the length of the hose.
  - **If Auto Stop is on**, monitor and assist the auto stop process as needed, shutting pipeline valve for the hose off as required.
    - (a) If this is a standard linear machine continue with step 14 of this instruction to run machine back across the field in the opposite direction.
    - (b) If this is a Swing Around linear machine and the operator intends to swing the machine around to the other field, proceed to the Swing Around section, follow the Swing Around procedure and swing the machine around to the other field. After swinging machine around, return to this instruction and continue with step 14 to run machine back across the field in the opposite direction..
14. Reposition the end of field/hose stop for the length of hose being used.
15. If using the optional electric cord drag:
- (a) Make sure the power pedestal disconnect, that the electric cord is connected to, is in the OFF position.
  - (b) Position the electric cord far enough away from the hose, so that the hose will not drag over it. To prevent interference between the electric cord, cart tires, furrow guidance system and hose, bury the electric cord in the area where interference will occur or when applicable, position the electric cord over the top of hose. See figure 53-1.
  - (c) When ready, switch the power pedestal disconnect switch into the ON position.
16. At the machine/control panel:
- (a) Select the desired direction of travel.
  - (b) Set the percentage timer to the desired application rate.
  - (c) If applicable set the Auto Reverse/Auto Stop control as desired.
17. When ready, start the machine. If applicable, start pipeline pump and open the water shut off valve for the hose. The machine should start and run in the desired direction and auto reverse or stop at the end of field/hose stop post which was set for the length of the hose.
18. Repeat the steps 6-11 as needed to cross the field in the opposite direction.

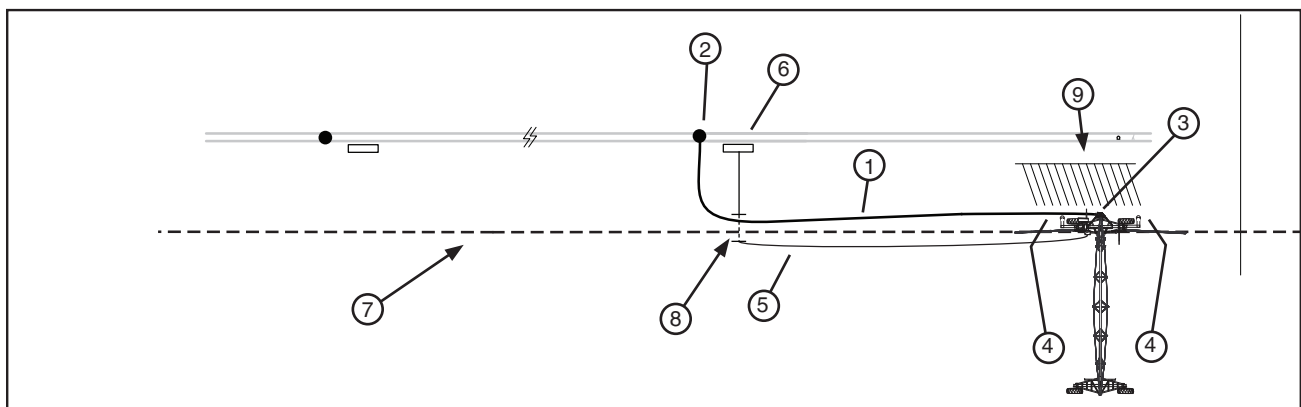

Figure 53-1 1. Hose 3. Swivel Inlet 5. Electric Cord (optional) 7. Furrow  
2. Shut Off Valve 4. Hose Bumper (optional) 6. Power Pedestal 8. Buried Cable Under Furrow  
9. Smooth, Hard Location For Hose

# OPERATION

## Closed Delivery Swing Around Linear

The following instructions describe how to position the hose and optional electric cord for the swing around 2 wheel linear depending on direction of machine movement and position of machine in relationship to the pipeline and power pedestals as the machine moves across the field.

1. Connect the first hose to the pipeline shut off valve and linear cart swivel inlet, then latch in place. See figure 54-1.
  - Temporarily installing a post approximately 6 ft (1.82M) behind the linear cart and on the pipeline side of the hose will aid in connecting the polyethylene hose to the linear cart inlet. See figure 54-1.
2. Set the end of field/hose stop post for the length of the first hose being used.
3. If using the optional electric cord drag:
  - (a) Position the electric cord far enough away from the hose, so that the hose will not drag over it. When applicable, prevent interference between the electric cord and hose by positioning the electric cord over the top of hose. See figure 54-1.
  - (b) Make sure the first power pedestal disconnect is in the OFF position.
  - (c) Connect the electric cord to the first power pedestal.
  - (d) When ready, switch the first power pedestal disconnect switch into the ON position.
4. At the control panel:
  - (a) Set the direction of travel.
  - (b) Set the percentage timer to the desired application rate.
5. When ready, start the machine and open the water shut off valve for the first hose. The machine should start and run in the desired direction and stop at the end of field/hose stop post which was set for the length of the first hose.

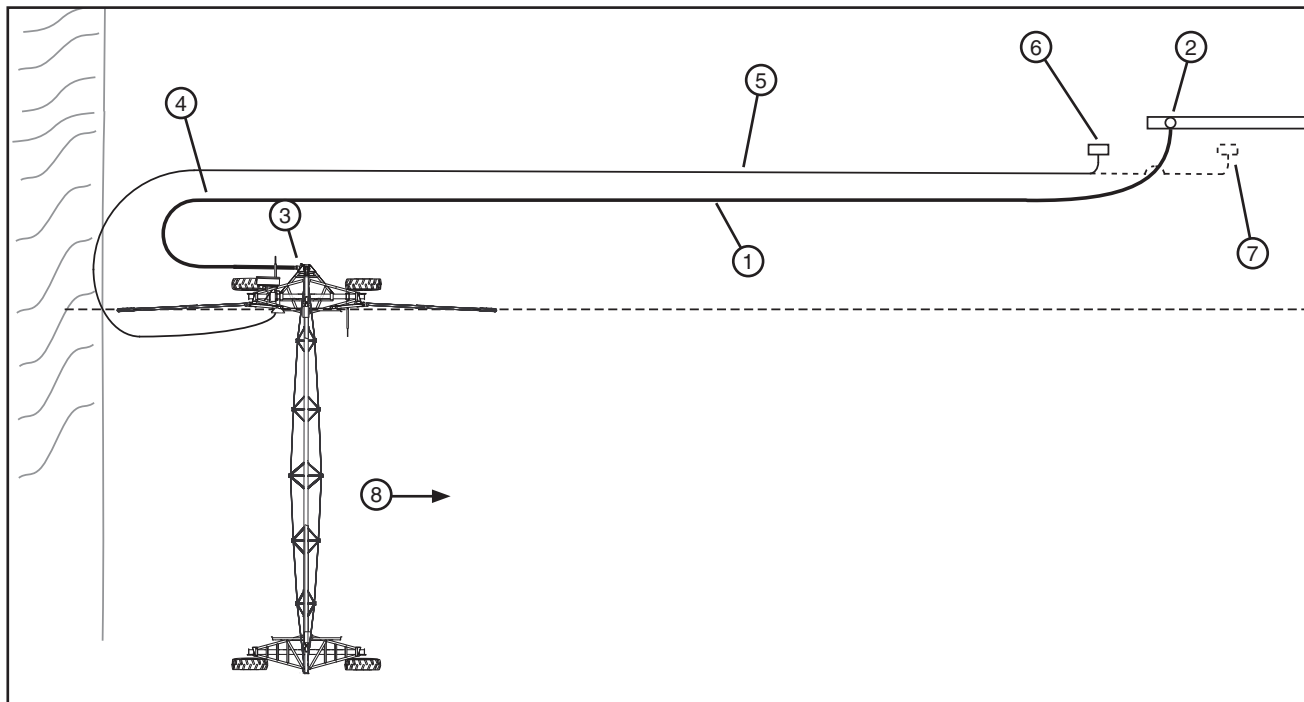

Figure 54-1 1. First Hose 4. Temporary Post (optional) 7. Alternate Power Pedestal Location and Electric Cord Position  
2. Shut Off Valve 5. Electric Cord 6. Power Pedestal  
3. Swivel Inlet 8. Direction of Travel

# OPERATION

## Closed Delivery

### Swing Around Linear (continued)

6. As the machine approaches the end of field/hose stop post, Stop the machine and close the water shut off valve for the first hose. See figure 55-1.
7. Disconnect the first hose from the shut off valve so that water from the hose drains away from the cart path. Then unlatch and disconnect first hose from swivel inlet. See figure 55-2.

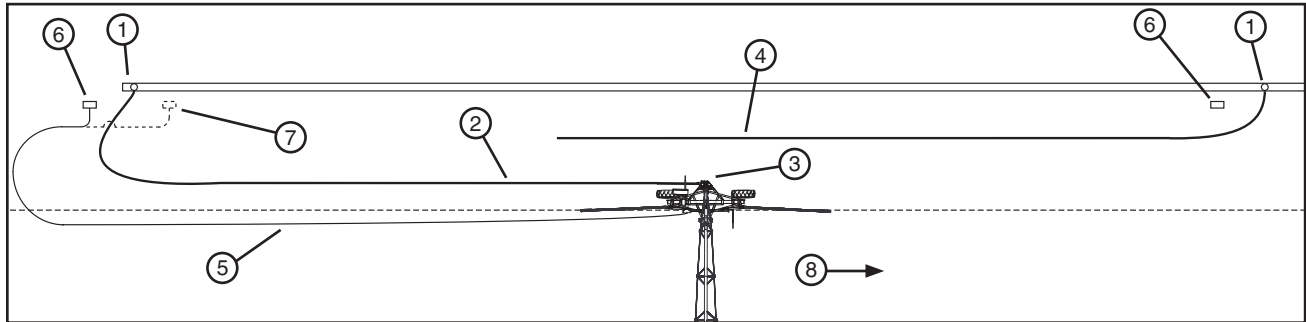

Figure 55-1 1. Shut Off Valve 3. Swivel Inlet 5. Electric Cord 7. Alternate Power Pedestal Location and Electric Cord Position  
2. First Hose 4. Second hose 6. Power Pedestal 8. Direction of Travel

8. With second hose connected to shut off valve, position second hose, connect to swivel inlet and latch in place. Reposition the end of field/hose stop for the length of the second hose being used. See figure 55-2.
9. If using the optional electric cord drag:
  - (a) Make sure the first power pedestal disconnect is in the OFF position.
  - (b) Disconnect the electric cord from the first power pedestal.
  - (c) Position the electric cord far enough away from the hose, so that the hose will not drag over it. When applicable, prevent interference between the electric cord and hose by positioning the electric cord over the top of hose. See figure 55-2.
  - (d) Make sure the second power pedestal disconnect is in the OFF position.
  - (e) Connect the electric cord to the second power pedestal.
  - (f) When ready, switch the second power pedestal disconnect switch into the ON position.
10. At the control panel:
  - (a) Select the original direction of travel.
  - (b) Set the percentage timer to the desired application rate.
11. When ready, start the machine and open the water shut off valve for the second hose.. The machine should start and run in the original direction and stop at the end of field/hose stop post which was set for the length of the second hose.
12. Repeat the steps 6-11 as needed to cross the field in the same direction.

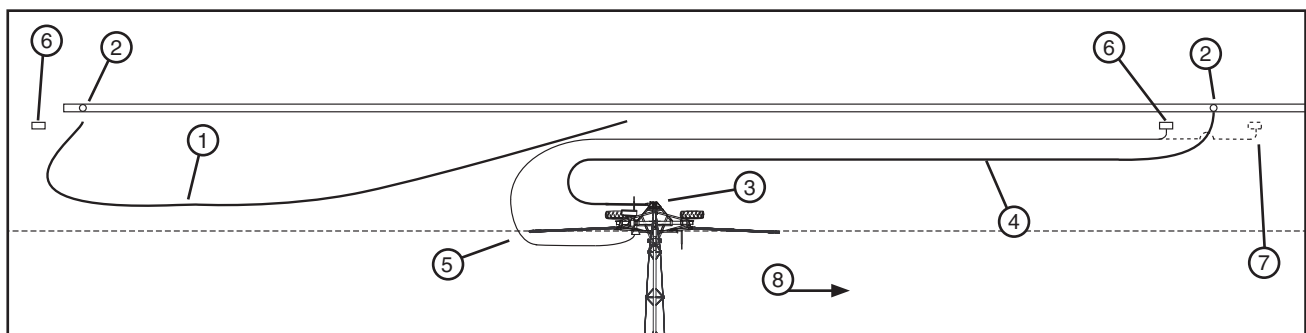

Figure 55-2 1. First Hose 3. Swivel Inlet 5. Electric Cord 7. Alternate Power Pedestal Location and Electric Cord Position  
2. Shut Off Valve 4. Second hose 6. Power Pedestal 8. Direction of Travel

# OPERATION

## Closed Delivery Swing Around Linear (continued)

13. As the machine approaches the edge of the field but before the machine reaches the end of field/hose stop:
  - (a) Stop the machine.
  - (b) Close the water shut off valve for the hose.
  - (c) Disconnect the hose from the shut off valve so that water from hose drains away from cart path.
  - (d) Unlatch and disconnect hose from swivel inlet.
14. Prepare to swing the machine around:
  - (a) Rotate the swivel inlet 90° and align with the tee inlet under the cart. Slide the tee inlet into the swivel inlet and latch tee inlet in place.
  - (b) Position hose so that the machine will not run over the hose during the swing around/pivot operation.
  - (c) If using the optional electric cord drag, protect the electric cord during the swing around/pivot operation.
15. Follow the Swing Around procedure located in this manual and swing the machine around to the other field. After swinging machine around, proceed with step 16 of this instruction.
16. Position and connect a soft hose with pulling chains to the hard hose, then to the cart. DO NOT connect the hard hose directly to the tee inlet. See figure 56-1.
17. Connect hose to the shut off valve. See figure 56-1.
18. Reposition the end of field/hose stop for the length of hose being used.
19. At the control panel:
  - (a) Select the original direction of travel.
  - (b) Set the percentage timer to the desired application rate.
20. When ready, start the machine and open the water shut off valve for the hose.. The machine should start and run in the opposite direction and stop at the end of field/hose stop post which was set for the length of the hose.

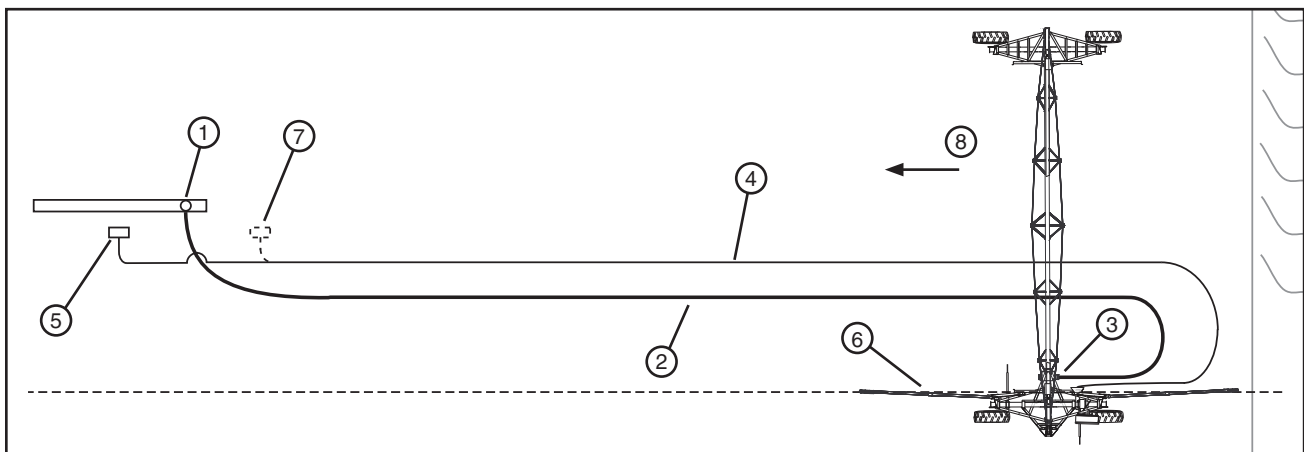

Figure 56-1 1. Shut Off Valve 3. Tee Inlet 5. Power Pedestal 7. Alternate Power Pedestal and Electric Cord Position  
2. Hose 4. Electric Cord 6. Furrow Guidance Skid 8. Direction of Travel



## Closed Delivery

### Swing Around Linear (continued)

21. As the machine approaches the end of field/hose stop post, Stop the machine and close the water shut off valve for the first hose. See figure 57-1.

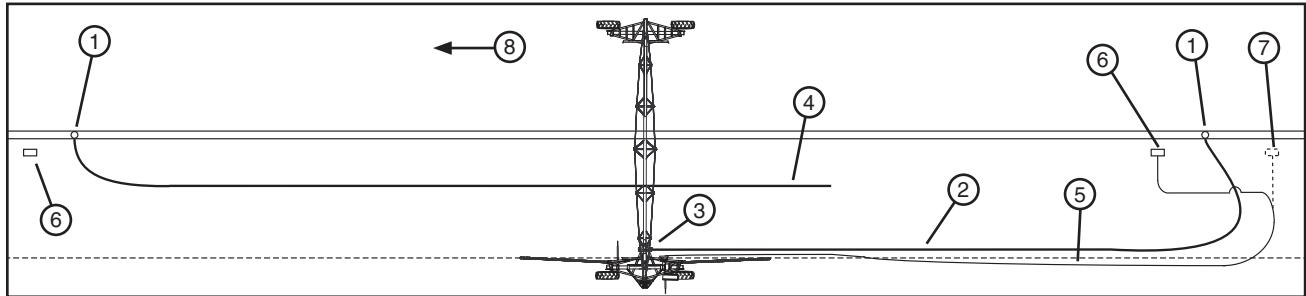

Figure 57-1 1. Shut Off Valve 3. Tee Inlet 5. Electric Cord 7. Alternate Power Pedestal and Electric Cord Position  
2. First Hose 4. Second Hose 6. Power Pedestal 8. Direction of Travel

22. Disconnect the first hose from the shut off valve so that water from the hose drains away from the cart path. Then unlatch and disconnect first hose from tee inlet. See figure 57-2.

23. With second hose connected to shut off valve, position second hose, connect to tee inlet and latch in place. Reposition the end of field/hose stop post for the length of the second hose being used. See figure 57-2.

24. If using the optional electric cord drag:

- (a) Make sure the first power pedestal disconnect is in the OFF position.
- (b) Disconnect the electric cord from the first power pedestal.
- (c) Position the electric cord far enough away from the hose and furrow guidance skid, so that the hose or furrow guidance skid will not drag over it. When applicable, prevent interference between the electric cord and hose by positioning the electric cord over the top of hose. See figure 57-2.
- (d) Make sure the second power pedestal disconnect is in the OFF position.
- (e) Connect the electric cord to the second power pedestal.
- (f) When ready, switch the second power pedestal disconnect switch into the ON position.

25. At the control panel:

- (a) Select the original direction of travel.
- (b) Set the percentage timer to the desired application rate.

26. When ready, start the machine and open the water shut off valve for the second hose.. The machine should start and run in the original direction and stop at the end of field/hose stop post which was set for the length of the second hose.

27. Repeat the steps 21-26 as needed to cross the field in the same direction.

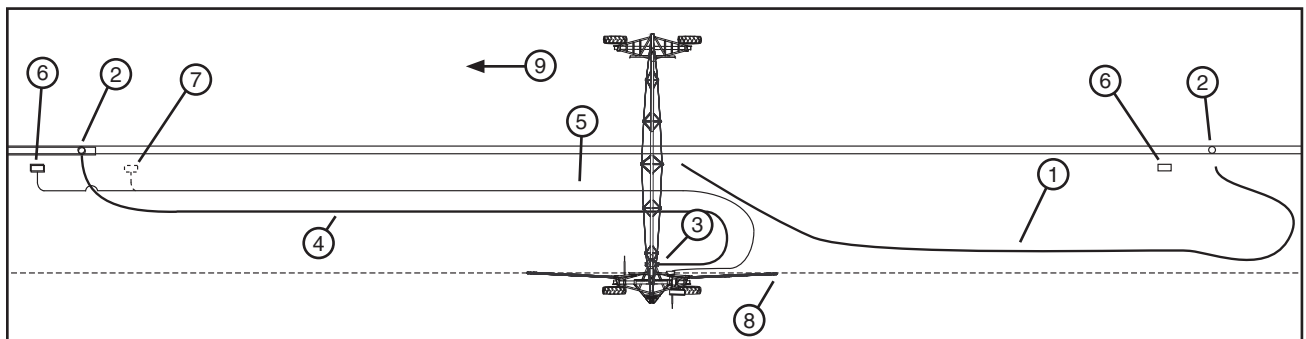

Figure 57-2 1. First Hose 4. Second hose 7. Alternate Power Pedestal and Electric Cord Position  
2. Shut Off Valve 5. Electric Cord 8. Furrow Guidance Skid  
3. Tee Inlet 6. Power Pedestal 9. Direction of Travel

# OPERATION

## Closed Delivery Swing Around Linear (Continued) Pivoting Methods

There are two methods for pivoting the 2 wheel swing around linear. The fixed wheel method and the concrete anchor method.

### Fixed Wheel

This method is simplest and requires no anchor and/or extra hardware on the cart. It can be used pivot the 2 wheel linear in the clockwise or counter clockwise direction where accurate tracking is not required.

1. Raise, fold and secure the furrow guidance arms up against drive tower to prevent possible damage to the furrow guidance arms while pivoting the machine.
2. Disconnect the hose from the elbow or tee inlet.
3. If the optional electric cord drag is used, make sure the electric cord is re-positioned to prevent possible damage while pivoting the machine.
4. Swing both cart tires to the tow position.
5. Leave the torque pin installed in the hub torque pin receiver on the pivot point cart wheel so that this wheel will not rotate (fixed). See figure 58-1.
6. Remove the torque pin from the hub torque pin receiver on the other cart wheel so that this wheel will rotate. See figure 58-1.
7. When the machine is started it will pivot around the center of the fixed wheel. See figure 58-2.

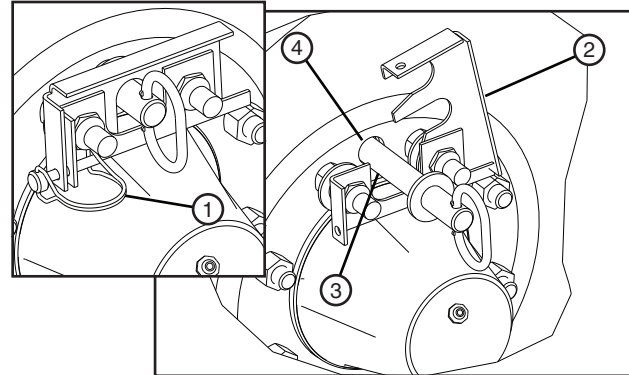

Figure 58-1 1. Lynch Pin  
2. Retainer Clip  
3. Torque Pin  
4. Hub Torque Pin Receiver

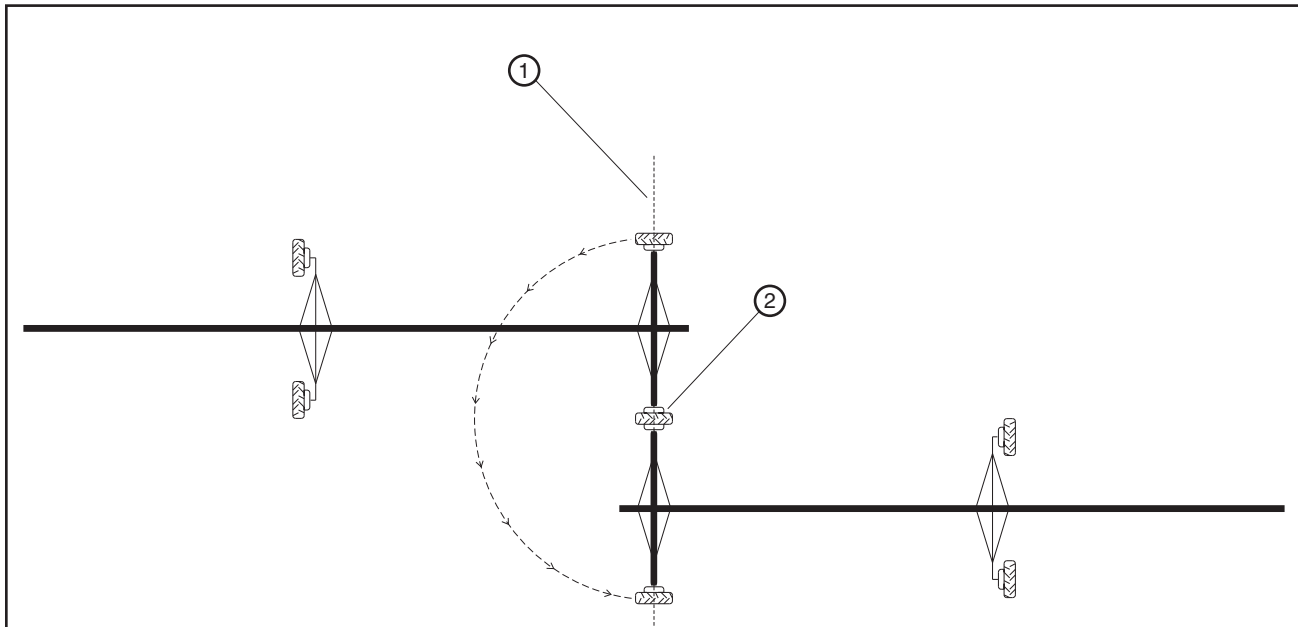

Figure 58-2 Fixed Wheel method.  
1. Furrow  
2. Pivot Point

### Swing Around Linear (Continued) Pivoting Methods Concrete Anchor

This method will provide a more secure anchor point for insuring that the base beam remains over the furrow and the other drive unit will follow the same track every time. This method requires a concrete anchor, buried in the field, in the furrow, with a chain buried in the concrete. The chain should extend 8 in to 10 in out of the concrete.

1. Raise, fold and secure the furrow guidance arms up against drive tower to prevent possible damage to the furrow guidance arms while pivoting the machine.
2. Disconnect the hose from the elbow or tee inlet.
3. If the optional electric cord drag is used, make sure the electric cord is re-positioned to prevent possible damage while pivoting the machine.
4. Swing both cart tires to the tow position.
5. Remove the torque pin from the hub torque pin receiver of both cart wheels. This will allow both wheels to rotate. See figure 59-1.
6. Tie the machine to the anchor with a load binder attached to one of the short chains on the drive unit depending on the direction the machine will be rotated. See figures 59-2.
7. When the machine is started it will pivot around the center of the base beam. See figures 59-2.

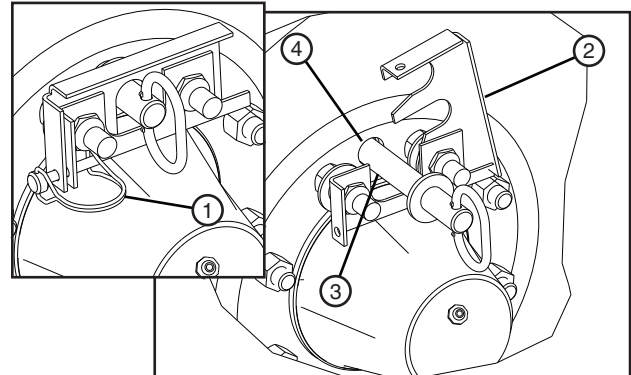

Figure 59-1 1. Lynch Pin 2. Retainer Clip 3. Torque Pin 4. Hub Torque Pin Receiver

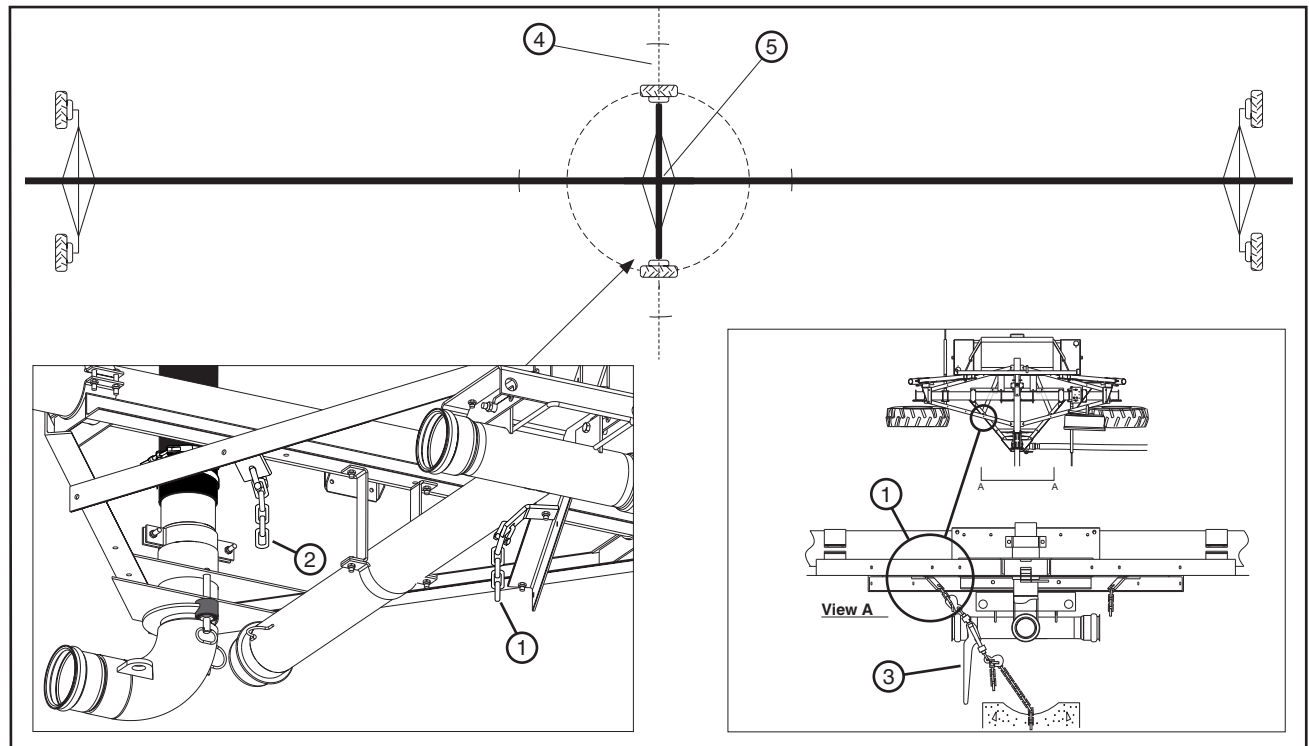

Figure 59-2 Concrete Anchor Method.  
1. Anchor for ClockWise Rotation (CW) 2. Anchor for Counter-Clockwise Rotation (CCW)  
3. Load Binder (Handle Oriented Downward) 4. Furrow  
5. Pivot Point

# OPERATION

## Closed Delivery Swing Around Linear (Continued) Preparing to Pivot

The following is a guide to preparing the Swing Around Linear for pivoting.

Prior to pivoting the machine do the following:

1. Position linear cart correctly over the pivot point. If the system has stopped at a point other than the desired, then adjust the end of hose stop post to the position required, then relocate the cart to the desired position.
2. Raise, fold and secure the furrow guidance arms up against the drive tower to prevent possible damage to the furrow guidance arms while pivoting the machine.
3. Disconnect the hose from the inlet and re-positioned away from the machine to prevent possible damage while pivoting the machine.
4. If the optional electric cord drag is used, make sure the electric cord is re-positioned and protected to prevent possible damage while pivoting the machine.
5. It is important that routine maintenance of the pivot area be performed. The pivot area must be kept clean of weeds or other debris.

## Classicplus Control Panel Pivoting Procedure

To pivot the span, position the machine correctly and follow all guidelines on the previous pages of this section. Then do the following:

1. At the control panel, switch the START/STOP rocker switch to the STOP position. See figure 60-1.
2. Switch the WATER ON/OFF rocker switch to the OFF position. See figure 60-1.

### NOTE

•The Linear Swing Around should always be ran dry (without water) when pivoting or swinging the span around.

3. Switch the PIVOT/LINEAR rocker switch to the pivot mode. See figure 60-1.
4. Set the FORWARD/REVERSE switch for the desired direction of travel that the machine will move in when started. See figure 60-1.
5. Set the percent timer to the desired percentage. See figure 60-1.
6. Switch the START/STOP rocker switch to the START position, to start the machine in the pivot mode. See figure 60-1.
7. When the machine reaches the end of pivot zone, switch the START/STOP rocker switch to the STOP position. See figure 60-1.
8. Switch the PIVOT/LINEAR rocker switch to the linear mode. See figure 60-1.

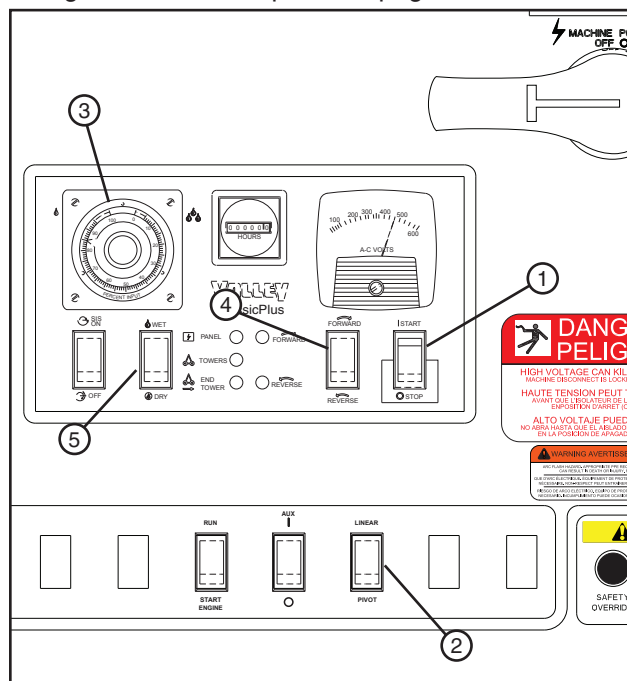

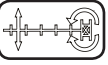
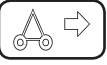
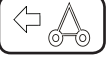
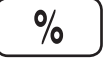

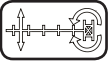

Figure 60-1 1. Start/Stop Switch  
2. Pivot/Linear Switch  
3. Percent Timer  
4. Forward/Reverse Switch  
5. Water ON/OFF switch

### Swing Around Linear (Continued) AutoPilot Control Panel Pivoting Procedure

To pivot the span, position the machine correctly and follow all guidelines on the previous pages of this section. Then do the following:

- At the control panel, press . See figure 61-1.
- Press  and **2** to change the machine to the pivot mode. See figure 61-1.
- Press the correct number key to select the pivot zone that the machine will be operating within.  
Select a Zone 1=A, 2=B, 3=C 4=D. See figure 61-2.
- Select the direction of movement for the span to pivot. See figure 61-2.
  - Press  for reverse.
  - OR
  - Press  for forward.
- Press  to set the percent timer to the desired percentage. See figure 61-2.
- Press  to start the machine in the pivot mode. See figure 61-3.
- Press  to stop the machine at the end of the pivot zone. See figure 61-4.
- Press  and **3** to return the machine to the linear mode. See figure 61-4.

### NOTE

- The Linear Swing Around should always be ran dry (without water) when pivoting or swinging the span around.

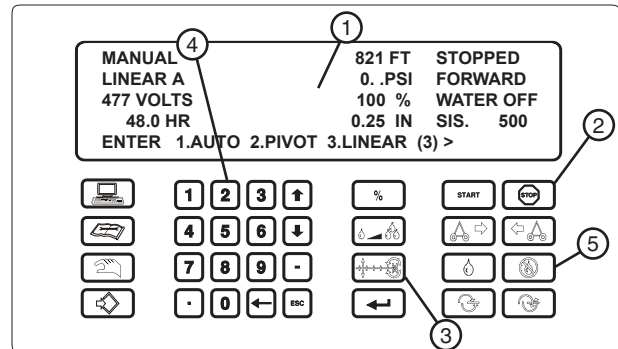

Figure 61-1 1. Control Panel Display. 4. Numeric Key.  
2. Stop Key. 5. Water OFF Key  
3. Pivot/Linear Key.

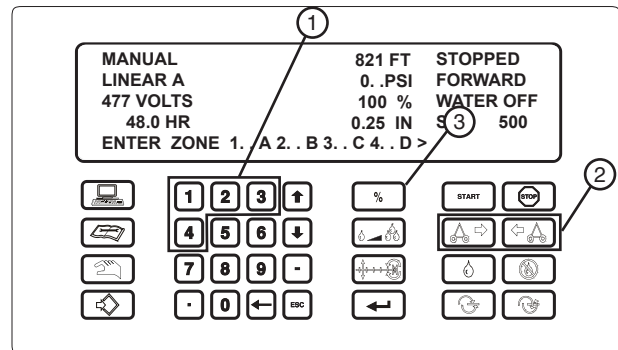

Figure 61-2 1. Numeric Keys 3. Percent Key  
2. Direction Keys

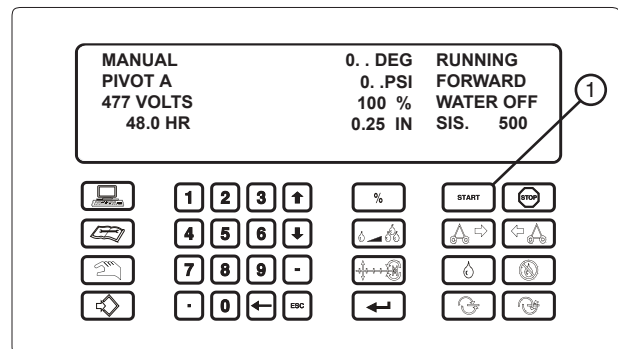

Figure 61-3 1. START key.

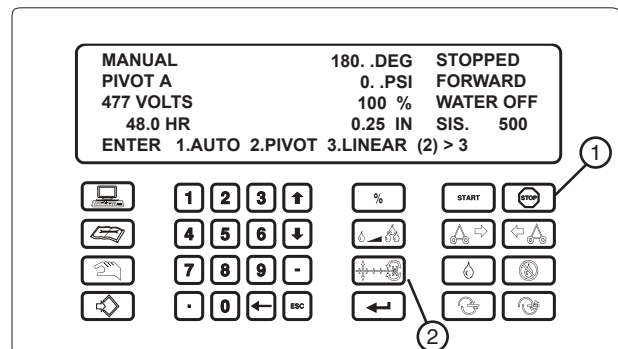

Figure 61-4 1. Stop Key 2. Pivot/Linear Key

# OPERATION

## Closed Delivery

### Towing Option

#### Preparing The Drive Units For Towing

This topic provides instruction on the preparation of the drive units for towing.

**REMEMBER: SAFETY FIRST – Operate according to the following procedures when towing and read all safety precautions in this manual.**

1. Position the machine in the tow lane. See figure 62-1.

### NOTE

- The tow lane should be flat and void of any crop rows.
- If towing on a side slope the machine may tend to shift down the hill due to gravitational pull.
- DO NOT tow across crop rows, ditches or rough terrain.

2. Turn the power off at the main disconnect and secure with a lock. See figure 62-2.

### WARNING

- NEVER ATTEMPT TO LIFT THE ENTIRE DRIVE UNIT AT ONE TIME.
- IF THE JACK BEGINS TO SLIP OR MOVE OUT OF POSITION, STOP RAISING THE DRIVE UNIT IMMEDIATELY, LOWER THE DRIVE UNIT AND REPOSITION THE JACK.

### NOTE

- Position the jack so it will not interfere with the rotation of the tire, wheel gearbox, swivel mount or swivel mount hardware.

3. The wheels on each drive unit must be turned into the tow position. Use a jack to lift one side of the drive unit until the tire is off of the ground. See figure 62-3.
4. Loosen the clamps securing u-joint shields in position. Slide all four u-joint shields away from the gearboxes.

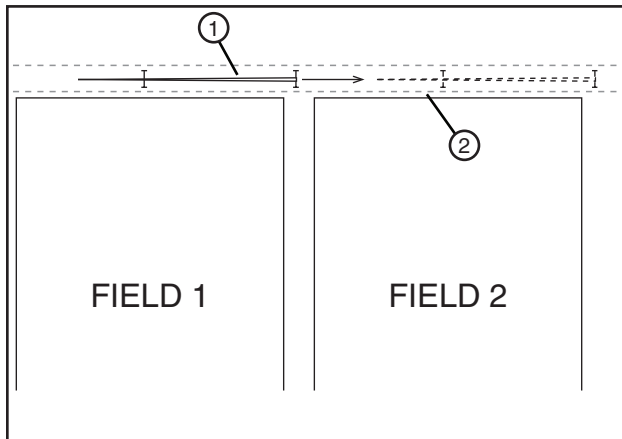

Figure 62-1 1. Machine  
2. Tow Lane

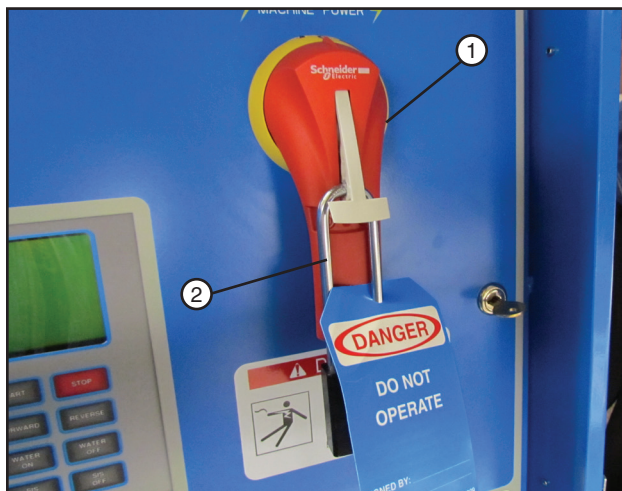

Figure 62-2 1. Main Disconnect  
2. Lock

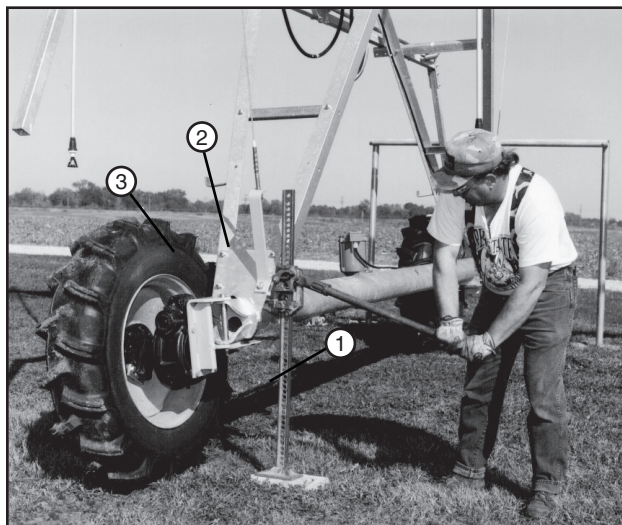

Figure 62-3 1. Jack 3. Tire  
2. Drive Unit



### Towing Option

### Preparing The Drive Units For Towing

5. Remove lynch pin from retainer clip, then open retainer clip and pull the torque pin from axle torque arm behind gearbox hub and hub torque pin receiver. See figure 63-1.
6. Using a pry bar, push down on the steering arm to release it from the latch plate. Push the tire toward the tow position until steering arm is out of latch plate. See figure 63-2.
7. As the tire is turned into the tow position, support the drive shaft and use a small pry bar to separate the drive shaft u-joint half from the flex joint and wheel gearbox u-joint half.

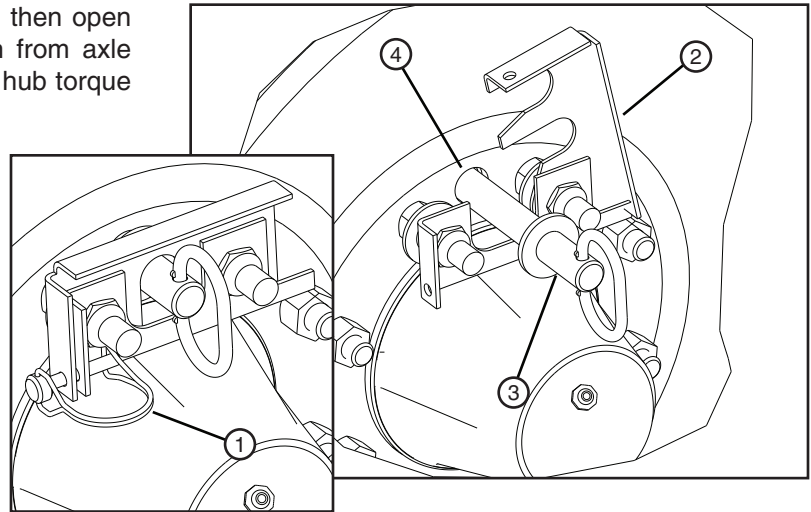

Figure 63-1 1. Lynch Pin 2. Retainer Clip 3. Torque Pin 4. Hub Torque Pin Receiver

After separating the u-joint, place the loose end of drive shaft in the drive shaft keeper. See figure 63-3.

8. If this is a TOWER drive unit, proceed to the FIXED TOW LINKAGE section.

If this is a CART drive unit, there are two(2) different types of towing linkage available for the cart drive unit, either Fixed or Steerable Tow Linkage.

- If the cart drive unit uses a tow link bar between the base beam and each steering arm to hold the tires in the tow position, proceed to the FIXED TOW LINKAGE section.
- If the cart drive unit uses tie rods between the tongue and each steering arm to provide steering at the cart end of machine, proceed to the STEERABLE TOW LINKAGE section.

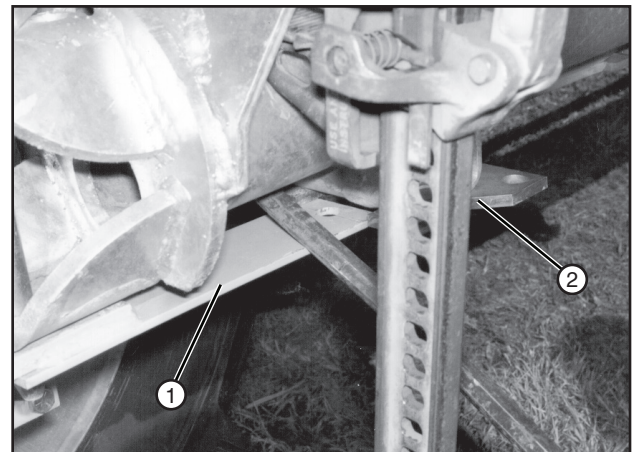

Figure 63-2 1. Steering Arm 2. Latch Plate

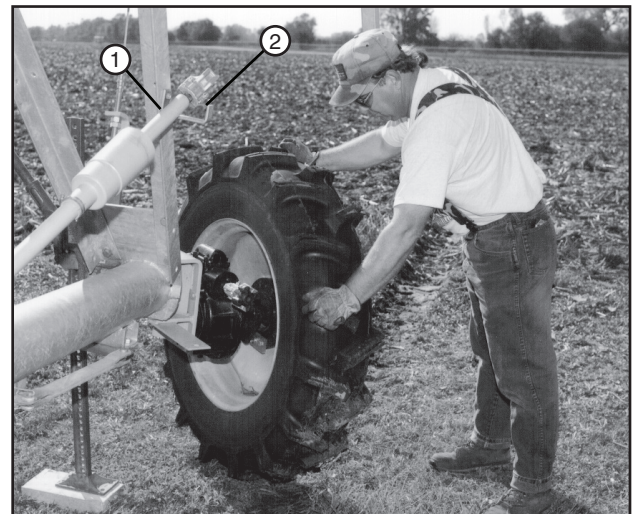

Figure 63-3 1. Drive Shaft 2. Drive Shaft Keeper



# OPERATION

## Closed Delivery Towing Option Fixed Tow Linkage

Fixed tow linkage is available on all drive units including the cart drive unit.

The fixed tow linkage uses a tow link bar between the base beam and steering arm to hold the tire in the tow position.

Use the following procedure to connect the fixed tow linkage.

1. Lift the carrier spring and release the tow link bar from the tow link carrier. See figure 64-1.
2. Position steering arm in tow link bar yoke, align holes, then attach steering arm to tow link bar with torque pin. Secure torque pin with lynch pin. See figure 64-2.
3. Lower the drive unit and remove the jack. The tire is now in the tow position.
4. Repeat steps 3-10 for all other fixed tow position drive unit tires.
5. On the cart drive unit do the following:
  - Disconnect the hose from the inlet tube at the elbow. See figure 64-3
  - Attach the tongue to the hose pull frame with torque pin. See figure 64-3.
  - If using the optional electric cord drag:
    - (a) Make sure that power pedestal disconnect is in the OFF position.
    - (b) Disconnect the electric cord from the power pedestal.
    - (c) Carefully coil and hand electric cord on machine to avoid damage when towing.

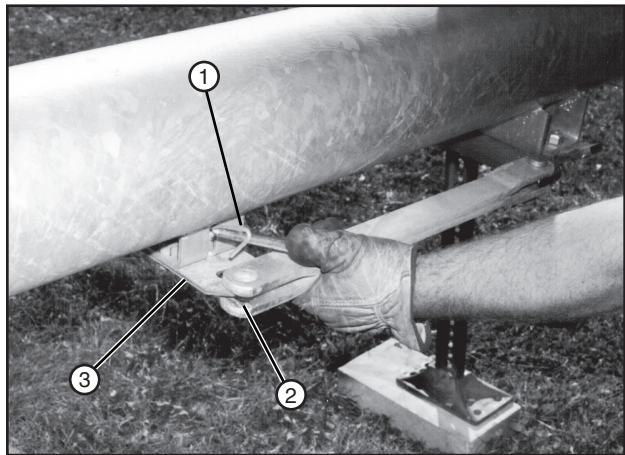

Figure 64-1 1. Carrier Spring 2. Tow Link Bar 3. Tow Link Carrier

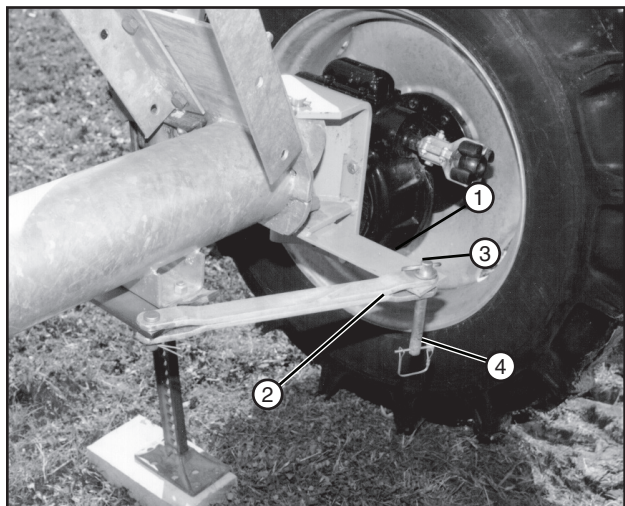

Figure 64-2 1. Steering Arm 2. Tow Link Bar Yoke 3. Torque Pin 4. Lynch Pin

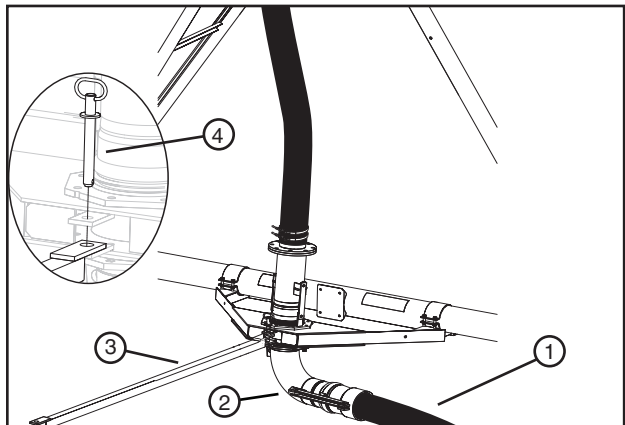

Figure 64-3 1. Hose 2. Elbow Inlet (Tee Inlet Not Shown) 3. Tongue 4. Torque Pin

### Towing Option Steerable Tow Linkage

Steerable tow linkage is only available on the cart drive unit.

Steerable tow linkage uses tie rods between the tongue and each steering arm to provide steering at the cart end of machine.

Use the following procedure to connect the steerable tow linkage.

1. Attach tongue with tie rods to the hose pull frame with torque pin. See figure 65-1.
2. Connect end of tie rod to steering arm with one clevis pin and hair pin. See figure 65-2.
3. Lower the drive unit and remove the jack. The tire is now in the tow position.
4. Repeat steps 3-10 for the other steerable tow drive unit tire.
5. On the cart drive unit do the following:
  - Disconnect the hose from the elbow or tee inlet. See figure 65-3.
  - If using the optional electric cord drag:
    - (a) Make sure the power pedestal disconnect is in the OFF position.
    - (b) Disconnect the electric cord from the power pedestal.
    - (c) Carefully coil and hang electric cord on machine to avoid damage when towing.

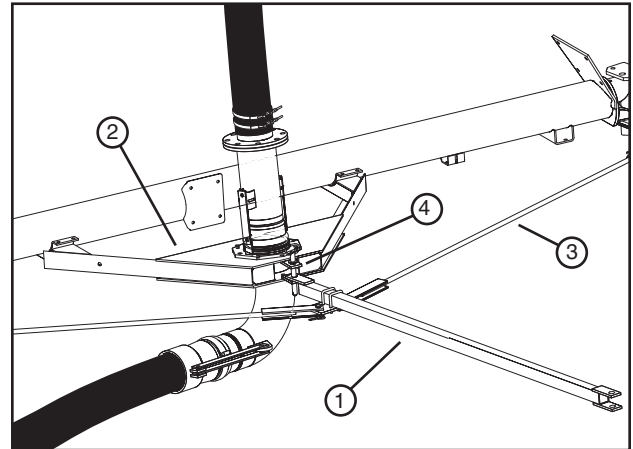

Figure 65-1 1. Tongue 2. Hose Pull frame 3. Tie Rod 4. Torque Pin

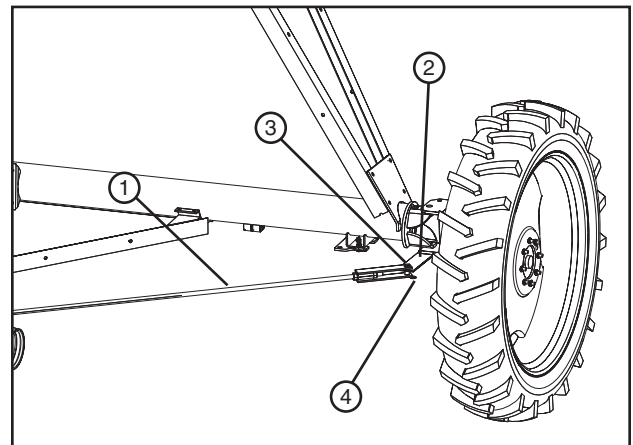

Figure 65-2 1. Tie Rod 2. Steering Arm 3. Clevis Pin 4. Hair Pin

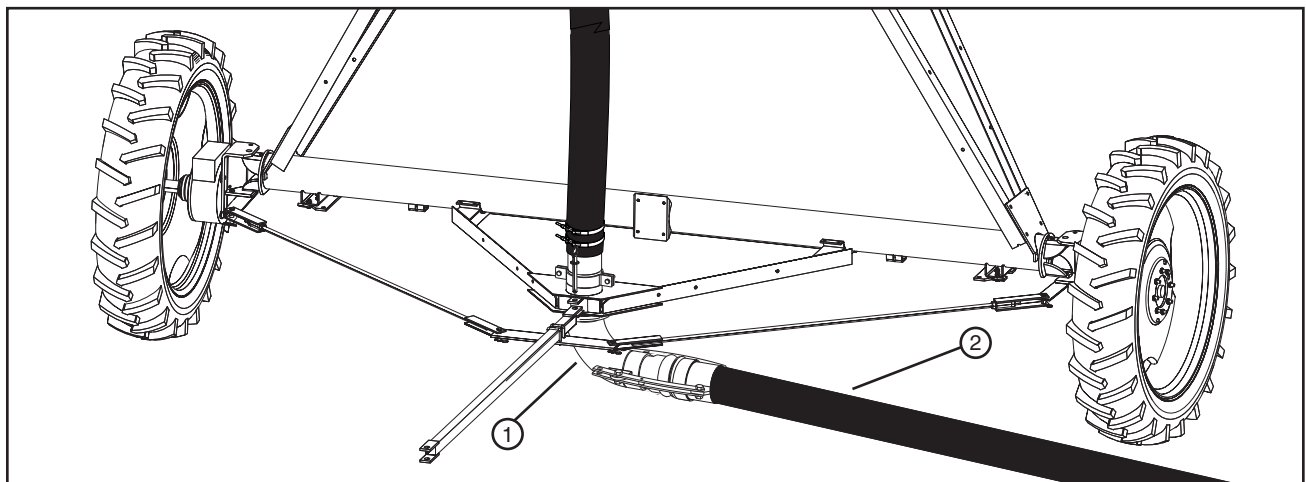

Figure 65-3 1. Hose 2. Elbow Inlet (Tee Inlet Not Shown)

# OPERATION

## Closed Delivery Towing The 2 Wheel Linear

This topic provides instruction on towing the 2 Wheel Linear.

**SAFETY FIRST - Operate according to the following procedures when towing and read all safety information in this manual.**

1. Position the machine in the tow lane. See figure 66-1.
2. Prepare the drive units for towing. See Preparing the Drive Units For Towing in the Towing Option Section.
3. If using the optional electric cord drag:
  - (a) Make sure the power pedestal disconnect is in the OFF position.
  - (b) Disconnect the electric cord from the power pedestal.
  - (c) Carefully coil and hang electric cord on machine to avoid damage when towing.
4. Make sure the hose is disconnected from the elbow inlet.
5. Attach the tongue to the towing unit. See figure 66-2.
6. After the cart and drive unit have been prepared for towing, begin towing the machine in a slow, gradual manner to the next location.
7. After reaching the next location, disconnect the tongue from the hose pull frame and the towing unit. Also disconnect tie rods from steering arms if using the steerable tow linkage.
8. Prepare the drive units for operation. See Preparing The Drive Units For Operation in the Towing Option Section. After preparing the drive units for operation the machine is ready for use.

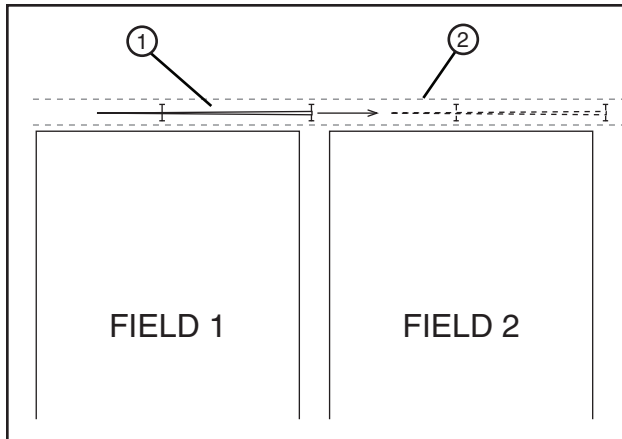

Figure 66-1 1. Machine  
2. Tow Lane

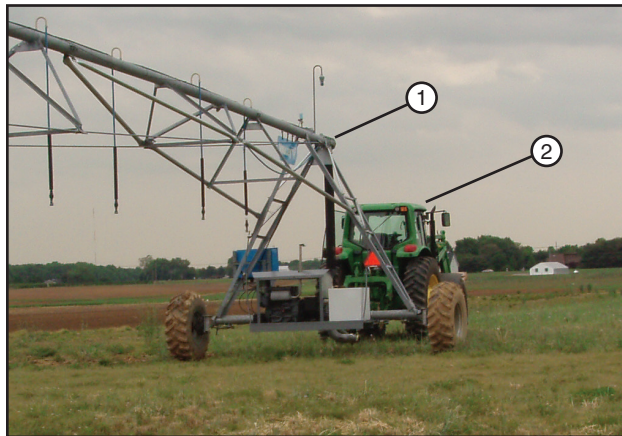

Figure 66-2 1. 2 Wheel Linear  
2. Towing Unit

## **CAUTION**

- TO REDUCE THE POSSIBILITY OF STRUCTURAL DAMAGE :
- IF TOWING ON A SIDE SLOPE THE MACHINE MAY TEND TO SHIFT DOWN THE HILL DUE TO GRAVITATIONAL PULL.
- DO NOT TOW ACROSS CROP ROWS, DITCHES OR ROUGH TERRAIN.
- DO NOT JERK THE MACHINE AT ANYTIME WHILE TOWING.
- DO NOT TOW THE MACHINE MORE THAN 2 MILES PER HOUR MAXIMUM.
- ALWAYS TOW THE MACHINE IN A STRAIGHT LINE.
- NEVER ATTEMPT TO TURN THE MACHINE WHEN TOWING.
- NEVER ATTEMPT REVERSING OR BACKING THE MACHINE INTO POSITION.



### Preparing The Drive Units For Operation

This topic provides instruction on the preparation of the drive unit for operation.

**REMEMBER: SAFETY FIRST – Operate according to the following procedures when towing and read all safety precautions in this manual.**

#### **⚠ WARNING**

- NEVER ATTEMPT TO LIFT THE ENTIRE DRIVE UNIT AT ONE TIME.
- IF THE JACK BEGINS TO SLIP OR MOVE OUT OF POSITION, STOP RAISING THE DRIVE UNIT IMMEDIATELY, LOWER THE DRIVE UNIT AND REPOSITION THE JACK.

#### **NOTE**

- Position the jack so it will not interfere with the rotation of the tire, wheel gearbox, swivel mount or swivel mount hardware.

1. Use a jack to lift one side of the drive unit until the tire is off of the ground. See figure 67-1.
2. For the cart drive unit do one of the following:
  - If the steerable tow linkage was used continue with step 5.
  - If fixed tow linkage was used continue with step 3.
3. Remove the lynch pin from the torque pin, then remove the torque pin and disconnect the tow link bar from the steering arm. See figure 67-1.
4. Rotate the tow link bar into the tow link carrier until the carrier spring latches into the hole in the tow link bar. See figure 67-2.
5. As the tire is turned to the operating position, align the drive shaft u-joint half with the flex joint and wheel gearbox u-joint half.

Continue pushing the tire toward the operating position with enough force to push the gearbox u-joint half over the flex joint and latch the steering arm in the latch plate.

6. Make sure the steering arm is latched in the latch plate. See figure 67-3.

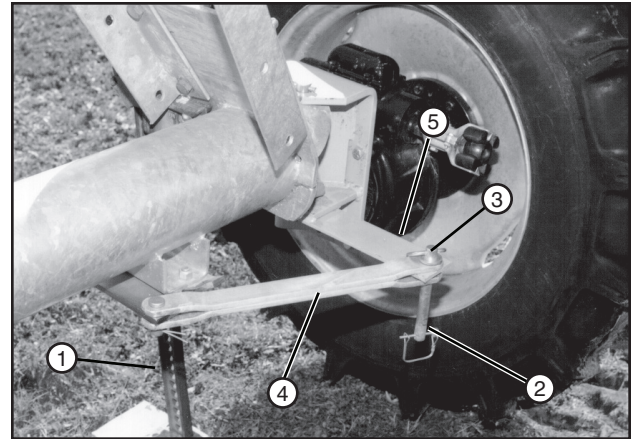

Figure 67-1 1. Jack  
2. Lynch Pin  
3. Torque Pin  
4. Tow Link Bar  
5. Steering Arm

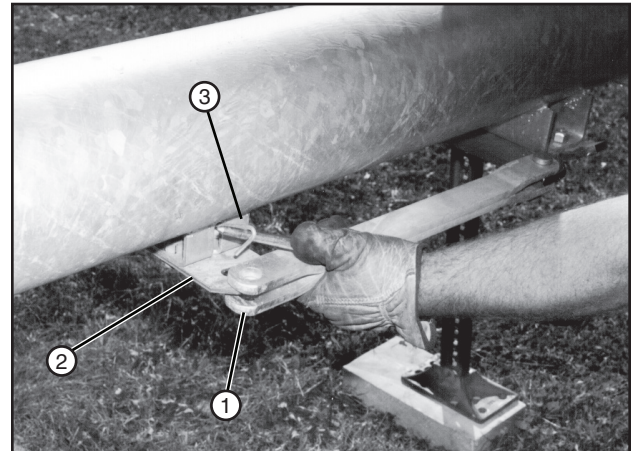

Figure 67-2 1. Tow Link Bar  
2. Tow Link Carrier  
3. Carrier Spring

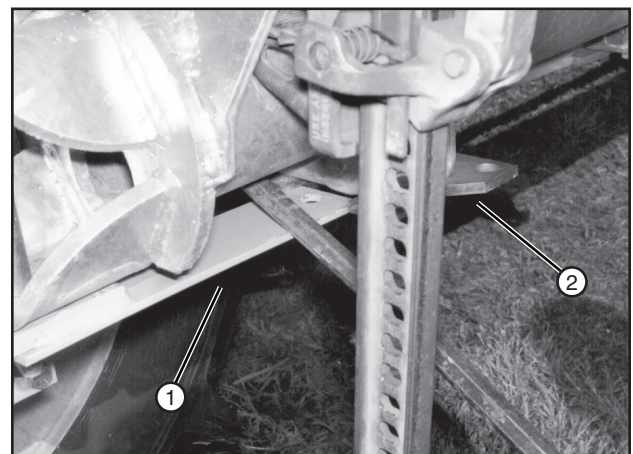

Figure 67-3 1. Steering Arm  
2. Latch Plate

# OPERATION

## Closed Delivery

### Preparing The Drive Units For Operation (Continued)

7. Slide the U-joint shield over the U-joint and position approximately 1/4 in away from touching the gearbox. Secure the U-joint shield to the drive shaft shield with a clamp. See figure 68-1.

Repeat the procedure for all U-joint shields.

8. Rotate the tire until the hole in the hub torque pin receiver is aligned with the hole in the axle torque arm. Install the torque pin and close the retainer plate. Secure the retainer plate to the retainer clip with the lynch pin. See figure 68-2.

9. Lower the drive unit and remove the jack. The tire is now in the OPERATING position. See figure 68-3.

10. Repeat steps 1-8 for all other drive unit tires.

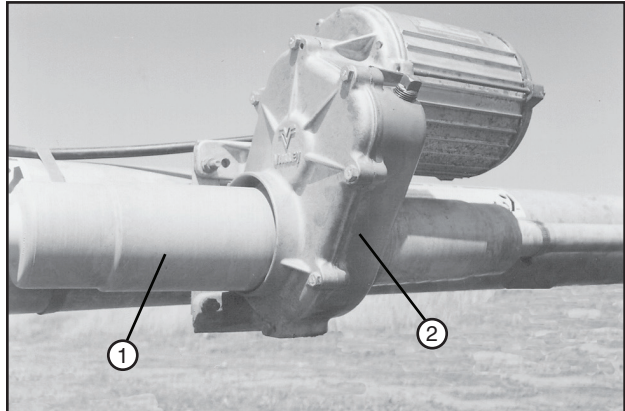

Figure 68-1 1. U-Joint Shield 2. Gearbox

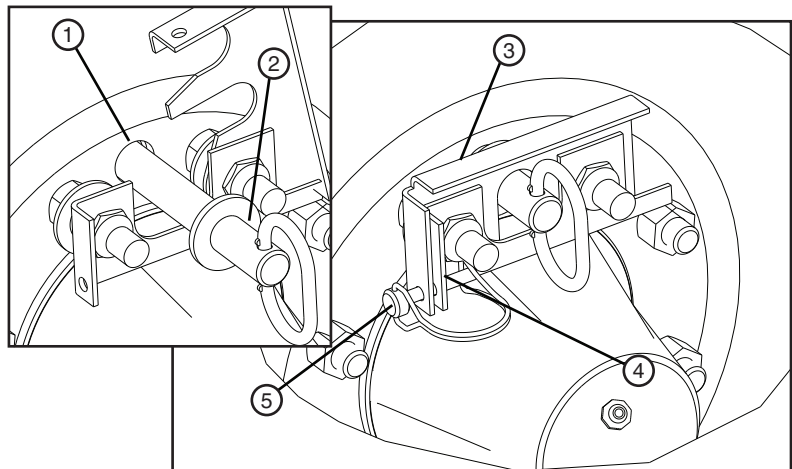

Figure 68-2 1. Hub Torque Pin Receiver 2. Torque Pin 3. Retainer Plate 4. Retainer Clip 5. Lynch Pin



Figure 68-3 1. Tire Shown In Operating Position

### Start Up - Engine Generator Electric Pump Applications

1. Inspect the wheel tracks to insure no vehicles or other equipment will be contacted upon start-up or operation.
2. Turn on the oscillator, if the system has below ground guidance.
3. Check the engine fuel, coolant, and oil levels. Fill as needed.
4. Check the centrifugal pump oil reservoir level. Fill as needed.
5. At the engine control panel, move the Remote Shutdown toggle switch to the Bypassed position. See figure 69-1.
6. Push the Reset button on the water pressure gauge.
7. Push and hold the red Safety button in while turning the Engine Start switch to START. When the engine starts, turn the Engine Start switch to the ON position and the safety button will hold itself in.
8. Turn the control panel disconnect to the ON position.
9. Check the voltmeter reading and verify that the generator is producing the correct Nominal Supply Voltage for this machine. See figure 69-2.



Figure 69-1 1. Safety Button 3. Engine Start Switch  
2. Toggle Switch 4. Water Pressure Gauge Reset

### **⚠ CAUTION**

- **DO NOT OPERATE THE MACHINE IF THE VOLT METER READS BELOW THE MINIMUM ALLOWED VOLTAGE OR ABOVE THE MAXIMUM ALLOWED VOLTAGE. SEE FIGURE 69-2.**
- **OPERATING THE MACHINE OUTSIDE THESE LIMITS COULD CAUSE DAMAGE TO THE DRIVE MOTORS AND OTHER ELECTRICAL COMPONENTS.**
- **CORRECT THE LOW VOLTAGE PROBLEM BEFORE RESUMING OPERATION.**

Nominal Supply Voltage	Maximum Allowed Voltage	Minimum Allowed Voltage
480 VAC @ 60Hz	505 VAC	440 VAC
415 VAC @ 50Hz	420 VAC	375 VAC
400 VAC @ 50Hz	420 VAC	365 VAC
380 VAC @ 50Hz	420 VAC	355 VAC
230 VAC @ 60Hz	253 VAC	220 VAC
120 VAC @ 60Hz	132 VAC	105 VAC
110 VAC @ 50Hz	121 VAC	95 VAC

Figure 69-2



# OPERATION

## Open Delivery

### Start Up - Engine Generator Electric Pump Applications (continued)

10. Determine if the machine will be run wet or dry.

- If running the machine wet, with water,
  - (a) Attach the suction inlet screen and hose to the elbow and clamp tightly with the Bauer style clamp.
  - (b) Lower suction inlet into ditch until the support suction arms are level. The suction screen should be on the ditch bottom in a trailing position with the machine See figure 70-1.
  - (c) Prime the centrifugal pump. See Hand Primer Pump on page 71. After the pump is primed return to this instruction.
  - (d) Continue with step 11.
- If running the machine dry, without water, raise the suction inlet completely out of the ditch, then continue with step 12.

11. Fill the system with water. Alternate between slowly opening the riser valve and turning on the single speed electric motor.

12. Refer to the appropriate Control Panel Owner's Manual for control panel operating procedures.

13. When the system is running and while holding the safety button in, move the remote shutdown toggle switch to the enabled position. See figure 70-2.

With the remote shutdown toggle switch in this position the engine will stop running if the system shuts down.

14. Check the voltmeter reading again while the generator is under load to verify that the generator is producing the correct Nominal Supply Voltage for this machine. See figure 70-3.

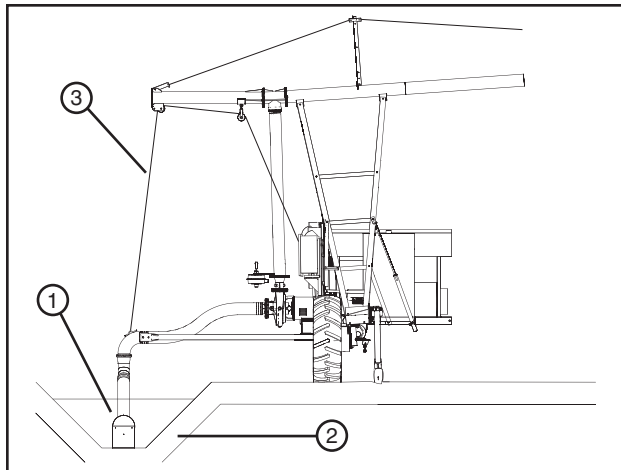

Figure 70-1 1. Suction Inlet 2. Ditch 3. Lift Cable



Figure 70-2 1. Safety Button 2. Toggle Switch 3. Engine Start Switch 4. Water Pressure Gauge Reset

## **⚠ CAUTION**

- **DO NOT OPERATE THE MACHINE IF THE VOLT METER READS BELOW THE MINIMUM ALLOWED VOLTAGE OR ABOVE THE MAXIMUM ALLOWED VOLTAGE. SEE FIGURE 70-3.**
- **OPERATING THE MACHINE OUTSIDE THESE LIMITS COULD CAUSE DAMAGE TO THE DRIVE MOTORS AND OTHER ELECTRICAL COMPONENTS.**
- **CORRECT THE LOW VOLTAGE PROBLEM BEFORE RESUMING OPERATION.**

Nominal Supply Voltage	Maximum Allowed Voltage	Minimum Allowed Voltage
480 VAC @ 60Hz	505 VAC	440 VAC
415 VAC @ 50Hz	420 VAC	375 VAC
400 VAC @ 50Hz	420 VAC	365 VAC
380 VAC @ 50Hz	420 VAC	355 VAC
230 VAC @ 60Hz	253 VAC	220 VAC
120 VAC @ 60Hz	132 VAC	105 VAC
110 VAC @ 50Hz	121 VAC	95 VAC

Figure 70-3



## Open Delivery

### Hand Pump Primer

The hand pump primer is used for priming of pump installations with suction inlets in a Centrifugal Pump Application. See figure 71-1.

1. Make sure that the drain cock is closed on the hand pump base. The drain cock should only be opened after priming to drain any liquids in the primer body See figure 65-1.
2. Close the riser valve, making sure that the suction screen is covered with water.
3. Open 3/4 in ball valve on Primer pump/Close riser pipe valve.
4. Pump the handle to prime the pump. When the clear plastic hose fills with water it is primed.
5. Close the 3/4 in ball valve.
6. Start electric pump motor.
7. Slowly open the riser pipe valve to fill the system with water.
8. After riser pipe valve is completely open and the system is full of water.
9. Open drain cock as needed to empty any liquid from the primer body

If you cannot get the primer to prime try the following:

- Make sure the drain cock is closed.
- Make sure riser valve is closed.
- Make sure there is no debris left inside where the check valve is. Any debris can cause clogging.
- Inspect the diaphragm for any tears or cracks.
- Check the line for any blockage or loops. The line must be straight and not twisted in any way.
- Check any strainers for blockage.
- Check all sections of the suction for air leaks.

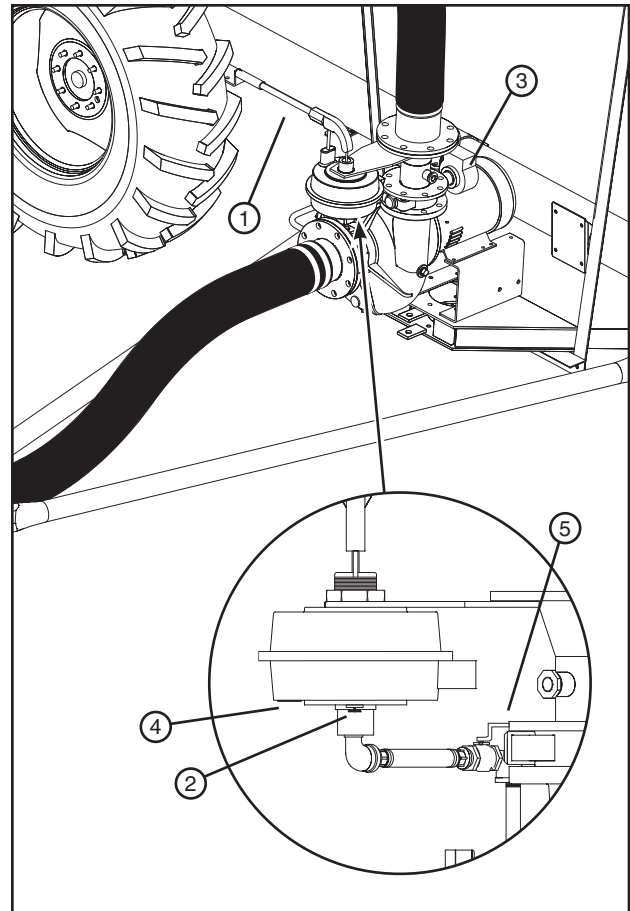

Figure 71-1 1. Primer Pump Handle 4. Check Valve  
2. Drain Cock 5. 3/4" Ball Valve  
3. Riser Pipe Valve

# OPERATION

## Open Delivery

### Start Up - Electric Cord / Motor Pump Applications

1. Inspect the wheel tracks to insure no vehicles or other equipment will be contacted upon start-up or operation.
2. If the machine has below ground guidance, turn the oscillator ON.
3. Connect electric cord to power source. Refer to Open Delivery Electric Cord Handling and Operation beginning on page 73, then return to this instruction and continue with step 4.
4. Check the centrifugal pump oil reservoir level.
5. Move the cart disconnect panel switch to the ON position. See figure 72-1.
6. Move the pump panel disconnect switch to the ON position. See figure 72-1.
7. Turn the control panel disconnect switch to the ON position. See figure 72-1.
8. Check the voltmeter reading and verify that the Nominal Supply Voltage is correct for this machine. See figure 72-2.
9. Determine if the machine will be run wet or dry.
  - If running the machine wet, with water:
    - (a) Attach the suction inlet screen and hose to the elbow and clamp tightly with the Bauer style clamp.
    - (b) Lower suction inlet into ditch until the support suction arms are level. The suction screen should be on the ditch bottom in a trailing position with the machine. See figure 72-3.
    - (c) Prime the centrifugal pump. See Hand Primer Pump on page 71. After the pump is primed, return to this instruction.
    - (d) Start the pump using the control panel. Refer to the appropriate Control Panel Owner's Manual for control panel operating procedures.
    - (e) Slowly fill the system with water. Slowly open the riser valve so that the pump does not loose prime.
    - (f) Refer to the appropriate Control Panel Owner's Manual for control panel operating procedures.
    - (g) Refer to Open Delivery Electric Cord Handling and Operation beginning on page 73 as needed.
  - If running the machine dry, without water, make sure the suction inlet is raised out of the ditch/water,
    - (a) Refer to the appropriate Control Panel Owner's Manual for control panel operating procedures.
    - (b) Refer to Open Delivery Electric Cord Handling and Operation beginning on page 73 as needed.

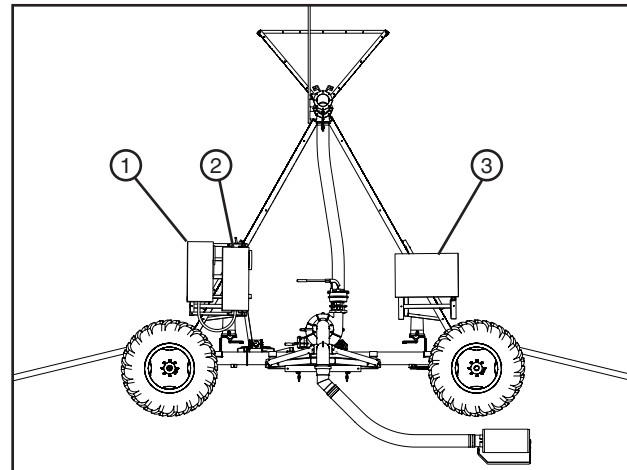

Figure 72-1 1. Cart Disconnect Panel  
2. Pump Disconnect Panel  
3. Control Panel

## **CAUTION**

- **DO NOT OPERATE THE MACHINE IF THE VOLT METER READS BELOW THE MINIMUM ALLOWED VOLTAGE OR ABOVE THE MAXIMUM ALLOWED VOLTAGE. SEE FIGURE 72-2.**
- **OPERATING THE MACHINE OUTSIDE THESE LIMITS COULD CAUSE DAMAGE TO THE DRIVE MOTORS AND OTHER ELECTRICAL COMPONENTS.**
- **CORRECT THE LOW VOLTAGE PROBLEM BEFORE RESUMING OPERATION.**

Nominal Supply Voltage	Maximum Allowed Voltage	Minimum Allowed Voltage
480 VAC @ 60Hz	505 VAC	440 VAC
415 VAC @ 50Hz	420 VAC	375 VAC
400 VAC @ 50Hz	420 VAC	365 VAC
380 VAC @ 50Hz	420 VAC	355 VAC

Figure 72-3

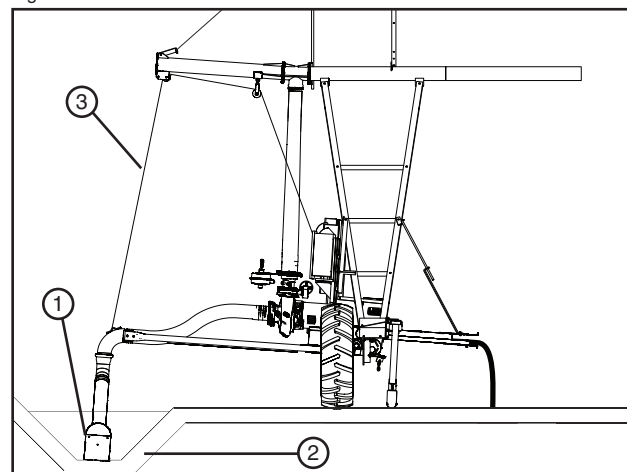

Figure 72-3 4. Suction Inlet 6. Lift Cable  
5. Ditch 7. Electric Cord

### Electric Cord Handling and Operation

#### **DANGER**

- NEVER HANDLE THE ELECTRIC CORD WHEN THE POWER IS ON.
- THE DISCONNECT SWITCH MUST BE IN THE “OFF” POSITION WHEN INSERTING OR REMOVING THE PLUG FROM THE RECEPTACLE.
- NEVER ALLOW THE ELECTRIC CORD TO KINK.
- NEVER ALLOW THE HOSE TO DRAG OVER THE ELECTRIC CORD ALWAYS LAY THE ELECTRIC CORD OVER THE HOSE.
- REGULARLY INSPECT THE ELECTRIC CORD FOR NICKS OR CUTS. REPLACE A DAMAGED ELECTRIC CORD IMMEDIATELY. DO NOT ATTEMPT TO SPLICE A DAMAGED ELECTRIC CORD.

#### **WARNING**

- DO NOT DRIVE ANY VEHICLE OVER THE CORD AT ANY TIME UNLESS THE CORD IS PROTECTED FROM PHYSICAL DAMAGE.
- REMOVE ALL SHARP OBJECTS FROM THE TRAVEL LANE THAT MAY CAUSE DAMAGE TO THE ELECTRIC CORD.
- ALWAYS INSURE THAT THE ELECTRIC CORD MECHANICAL SAFETY CABLE IS ROUTED THROUGH CABLE HOOK ON POWER PEDESTAL EACH TIME THE ELECTRIC CORD IS PLUGGED INTO THE RECEPTACLE.
- INSURE THAT THE MECHANICAL SAFETY CABLE IS FUNCTIONAL EACH TIME THE ELECTRIC CORD IS PLUGGED INTO POWER PEDESTAL. THE PLUG MUST ALWAYS BE FREE SO THAT THE MECHANICAL SAFETY CABLE CAN PULL THE PLUG FROM RECEPTACLE IF NECESSARY.
- ALWAYS ATTACH THE CAP TO PLUG WHEN MOVING THE ELECTRIC CORD AND PLUG FROM ONE POWER PEDESTAL TO ANOTHER, OR WHEN STORING THE CORD.
- THE PLUG CAP COLLAR IS FOR ATTACHMENT OF THE PLUG CAP ONLY! DO NOT ATTACH THE PLUG CAP COLLAR TO THE RECEPTACLE. THE PLUG MUST ALWAYS BE FREE SO THAT THE MECHANICAL SAFETY CABLE CAN PULL THE PLUG FROM RECEPTACLE IF NECESSARY.

### Electric Cord Operation

1. Ensure that the danger signs are in place and visible at each end of the travel lane. See figure 73-1.
2. Check the electric cord for nicks, cuts, or abrasions. DO NOT use the electric cord or start the system if any of these defects are found. Contact your local Valley dealer.

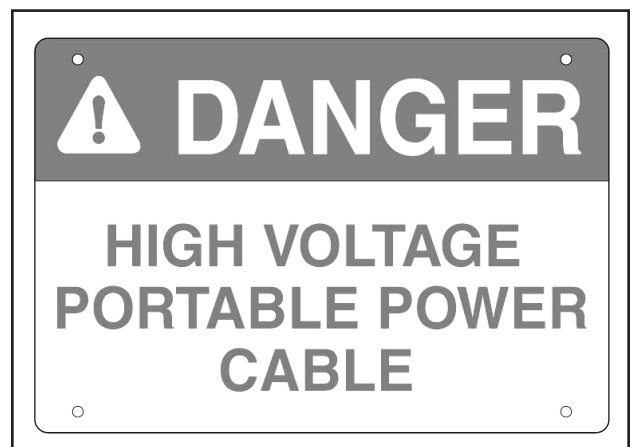

Figure 73-1 Danger Sign

# OPERATION

## Open Delivery Electric Cord Handling and Operation

- Turn the power pedestal disconnect switch to the OFF position. See figure 74-1.

### **⚠ DANGER**

•THE DISCONNECT SWITCH MUST BE IN THE “OFF” POSITION WHEN INSERTING OR REMOVING THE PLUG FROM THE RECEPTACLE.

- Remove plug cap from electric cord plug, and insert the electric cord plug into the power pedestal receptacle. See figure 74-1.

### **⚠ WARNING**

•ALWAYS ATTACH THE PLUG CAP TO THE PLUG WHEN MOVING THE ELECTRIC CORD FROM ONE POWER PEDESTAL TO ANOTHER OR WHEN STORING THE ELECTRIC CORD.

- Place the cord anchor cable through the mechanical cable anchor ring on the power pedestal.

For proper operation of the cord anchor cable disconnect, there must be slack in the electric cord between the cord grip and plug when the cord anchor cable is pulled taut. See figure 74-2.

### **⚠ WARNING**

•DO NOT ATTACH ELECTRIC CORD PLUG TO POWER PEDESTAL RECEPTACLE WITH PLUG CAP COLLAR.

- Turn the power pedestal disconnect switch to the ON position to energize the cart disconnect panel.

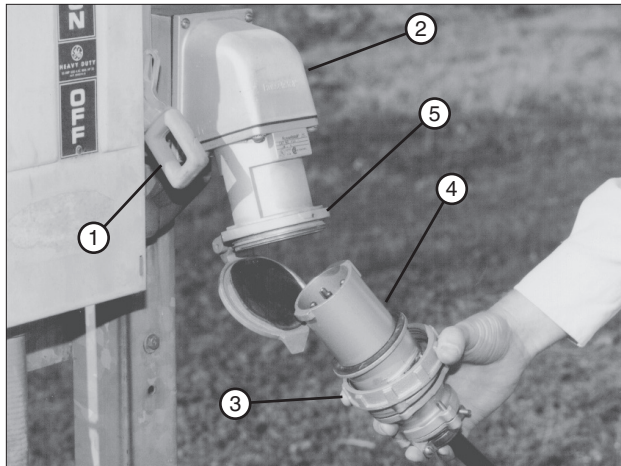

Figure 74-1 1. Disconnect Switch 2. Power Pedestal 3. Plug Cap Collar 4. Plug 5. Receptacle

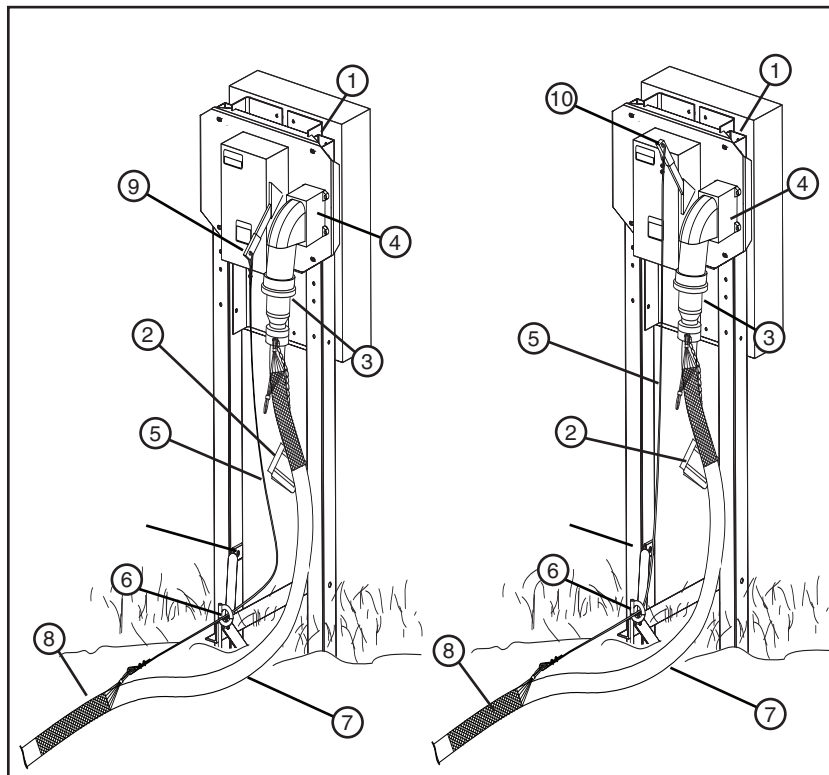

Figure 74-2 1. Power Pedestal 2. Plug Cap 3. Electric Cord Plug 4. Power Pedestal Receptacle 5. Cord Anchor Cable 6. Cable Anchor Ring 7. Electric Cord 8. Cord Grip 9. Disconnect Switch- OFF 10. Disconnect Switch - ON

### Electric Cord Handling and Operation Electric Cord Positioning

The following instructions describe a basic method of positioning the electric cord for open delivery depending on direction of machine movement and position of power pedestals as the machine moves across the field. (Ditch Feed Option Shown)

1. Connect electric cord:
  - (a) Make sure the power pedestal disconnect is in the OFF position.
  - (b) Position the electric cord between the cart and power pedestal so that it does not interfere with the furrow guidance arms if applicable. See figure 75-1.
  - (c) Connect the electric cord to the power pedestal.
  - (d) When ready, switch the power pedestal disconnect into the ON position.
2. Follow the instructions for Open Delivery Cord Drag Start Up.
3. When ready, start the machine. The machine should start and run in the desired direction and auto reverse or stop at the end of field stop post which was set for the length of the electric cord.
4. As the machine approaches the end of field stop post, Stop the machine and close the water shut off valve on the riser if applicable.
5. Move the electric cord:
  - (a) Make sure the power pedestal disconnect is in the OFF position.
  - (b) Disconnect the electric cord from the power pedestal.
  - (c) Position the electric cord between the cart and power pedestal so that it does not interfere with the furrow guidance arms if applicable. See figure 75-2.
  - (d) Make sure the second power pedestal disconnect is in the OFF position.
  - (e) Connect the electric cord to the second power pedestal.
  - (f) When ready, switch the second power pedestal disconnect into the ON position.

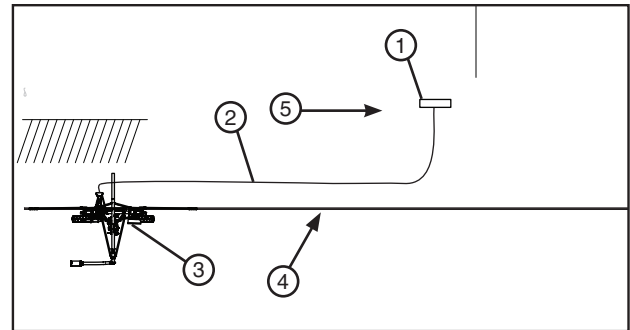

Figure 75-1 1. Power Pedestal  
2. Electric Cord  
3. Cart  
4. Guidance Furrow  
5. Direction of Travel

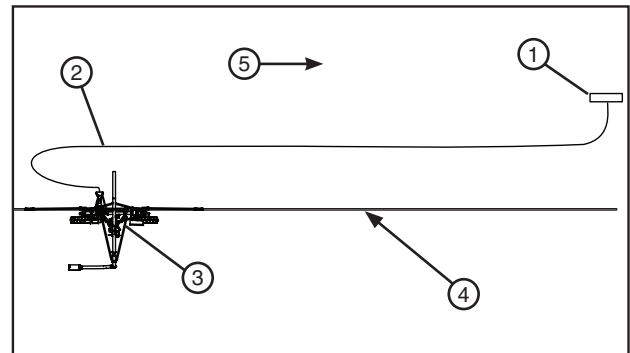

Figure 75-2 1. Power Pedestal  
2. Electric Cord  
3. Cart  
4. Guidance Furrow or Cable  
5. Direction of Travel

# OPERATION

## Open Delivery

### Electric Cord Handling and Operation Electric Cord Positioning (continued)

6. At the machine/control panel:
  - (a) Select the original direction of travel.
  - (b) Set the percentage timer to the desired application rate or speed.
  - (c) If applicable set the Auto Reverse/Auto Stop control as desired.
7. When ready, start the machine. If applicable, open the water shut off valve on the riser. The machine should start and run in the desired direction and auto reverse or stop at the end of field stop post which was set for the length of the electric cord.
8. Repeat the steps 9-13 as needed to cross the field.
9. As the machine approaches the edge of the field do one of the following:
  - **If Auto Reverse is on**, monitor and assist the auto reverse process as needed, closing and opening the riser valve as required.
    - (a) Reposition the end of field stop for the length of electric cord.
    - (b) The machine should start and run in the desired direction and stop at the end of field stop post which was set for the length of the electric cord.
  - **If Auto Stop is on**, monitor and assist the auto stop process as needed, closing the riser valve as required.
    - (a) If this is a standard linear machine continue with step 14 of this instruction to run machine back across the field in the opposite direction.
    - (b) If this is a swing around linear machine and the operator intends to swing the machine around to the other field, proceed to the Swing Around section, follow the Swing Around procedure and swing the machine around to the other field. After swinging machine around, return to this instruction and continue with step 14 to run machine back across the field in the opposite direction.
10. Reposition the end of field stop for the length of electric cord.

#### 11. Move electric cord:

- (a) Make sure the power pedestal disconnect, that the electric cord is connected to, is in the OFF position.
- (b) Position the electric cord between the cart and power pedestal so that it does not interfere with the furrow guidance arms if applicable. See figure 76-1.
- (c) When ready, switch the power pedestal disconnect switch into the ON position.

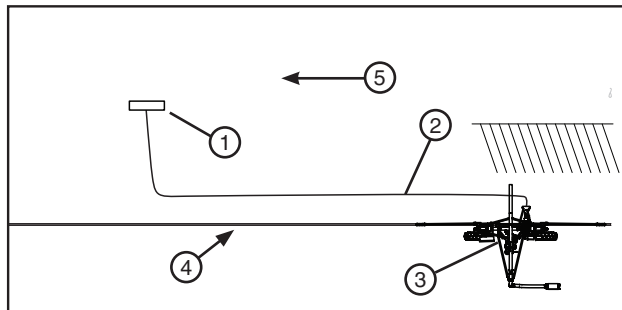

Figure 76-1 1. Power Pedestal  
2. Electric Cord  
3. Cart  
4. Guidance Furrow  
5. Direction of Travel

#### 12. At the machine/control panel:

- (a) Select the desired direction of travel.
- (b) Set the percentage timer to the desired application rate.
- (c) If applicable set the Auto Reverse/Auto Stop control as desired.

13. When ready, start the machine. If applicable, open the riser water shut off valve. The machine should start and run in the desired direction and auto reverse or stop at the end of field/hose stop post which was set for the length of the hose.

14. Repeat the steps 6-11 as needed to cross the field in the opposite direction.



### Swing Around Option Swing Around Methods

There are two methods for pivoting the 2 Wheel swing around linear. The fixed wheel method and the concrete anchor method.

#### Fixed Wheel

This method is simplest and requires no anchor and/or extra hardware on the cart. It can be used to pivot the 2 Wheel linear in the clockwise or counter clockwise direction where accurate tracking is not required.

1. Raise the suction inlet out of the ditch using the lift cable, high enough to clear obstructions, then disconnect the inlet tube at elbow as shown in figure 77-1. To prevent damage during swing around move machine away from the ditch so that the wheels will not fall in the ditch.
2. Raise, fold and secure the furrow guidance arms up against drive tower to prevent possible damage to the furrow guidance arms while pivoting the machine.
3. Swing both cart tires to the tow position.
4. Leave the torque pin installed in the hub torque pin receiver on the pivot point cart wheel so that this wheel will not rotate (fixed). See figure 77-2.
5. Remove the torque pin from the hub torque pin receiver on the other cart wheel so that this wheel will rotate. See figure 77-2.
6. When the machine is started it will pivot around the center of the fixed wheel. See figure 77-3.

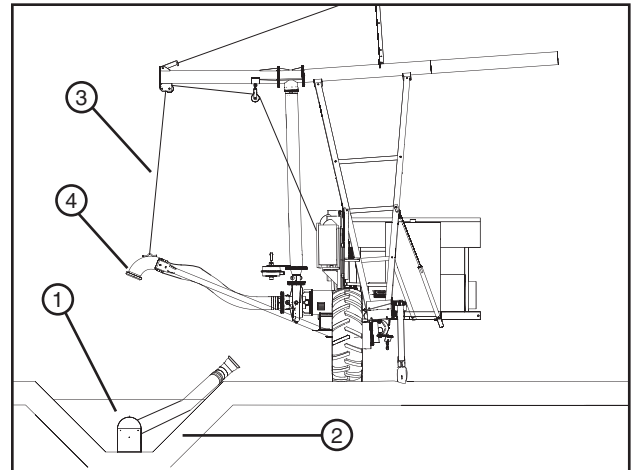

Figure 77-1 1. Suction Inlet 2. Ditch 3. Lift Cable 4. Elbow

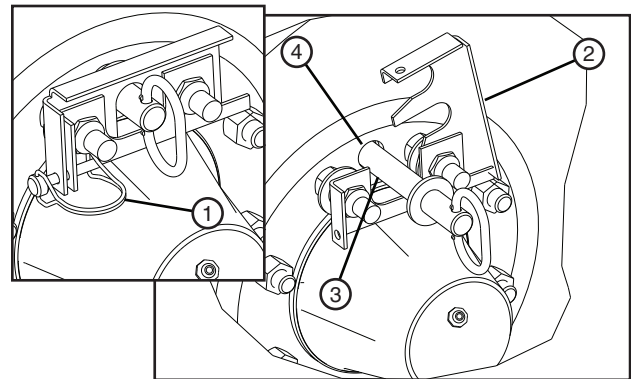

Figure 77-2 1. Lynch Pin 2. Retainer Clip 3. Torque Pin 4. Hub Torque Pin Receiver

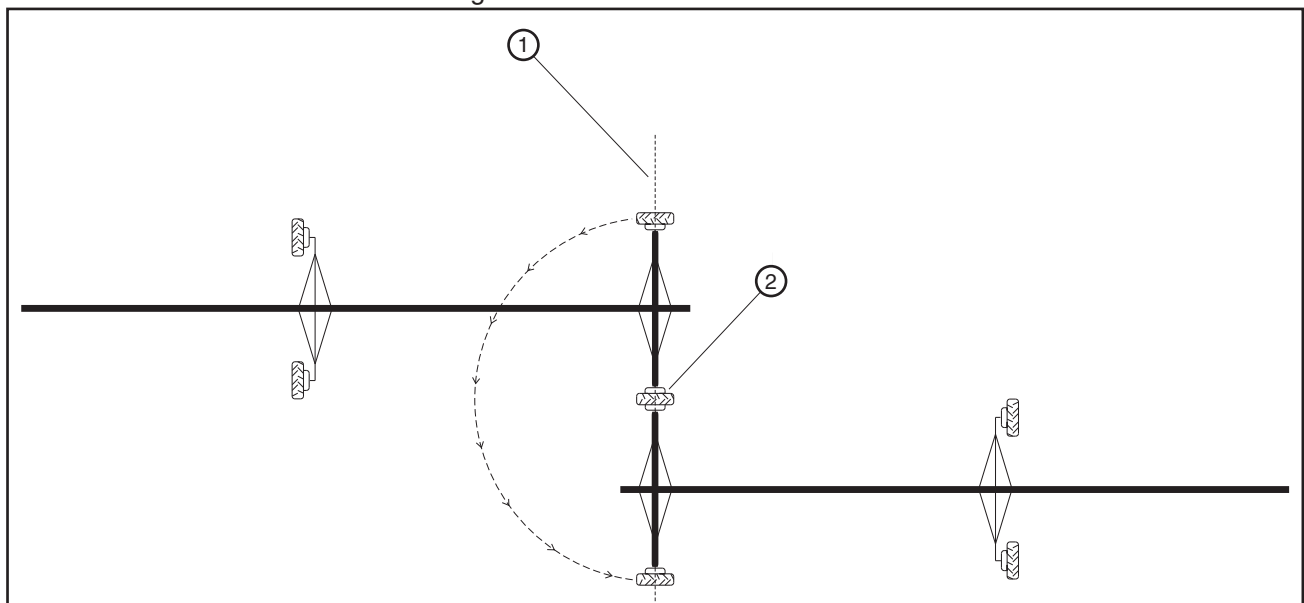

Figure 77-3 Fixed Wheel method.  
1. Furrow  
2. Pivot Point (Fixed Wheel)



# OPERATION

## Open Delivery Swing Around Option Swing Around Methods (Contiued) Concrete Anchor

This method will provide a more secure anchor point for insuring that the base beam remains over the furrow and the other drive unit will follow the same track every time. This method requires a concrete anchor, buried in the field, in the furrow, with a chain buried in the concrete. The chain should extend 8 in to 10 in out of the concrete.

1. Raise the suction inlet out of the ditch using the lift cable, high enough to clear obstructions, then disconnect the inlet tube at elbow as shown in figure 78-1. To prevent damage during swing around move machine away from the ditch so that the wheels will not fall in the ditch.
2. Raise, fold and secure the furrow guidance arms up against drive tower to prevent possible damage to the furrow guidance arms while pivoting the machine.
3. Swing both cart tires to the tow position.
4. Remove the torque pin from the hub torque pin receiver of both cart wheels. This will allow both wheels to rotate. See figure 78-2.
5. Tie the machine to the anchor with a load binder attached to one of the short chains on the drive unit depending on the direction the machine will be rotated. See figures 78-2.
6. When the machine is started it will pivot around the center of the base beam. See figures 78-3

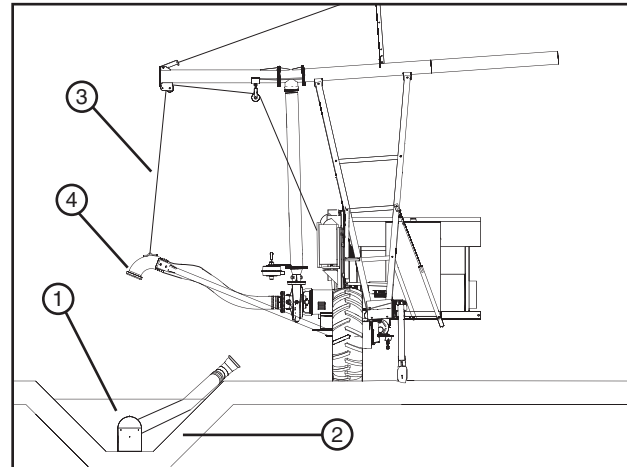

Figure 78-1 1. Suction Inlet 2. Ditch 3. Lift Cable 4. Elbow

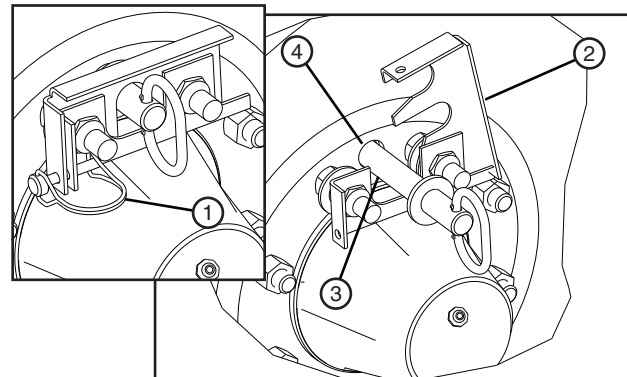

Figure 78-2 1. Lynch Pin 2. Retainer Clip 3. Torque Pin 4. Hub Torque Pin Receiver

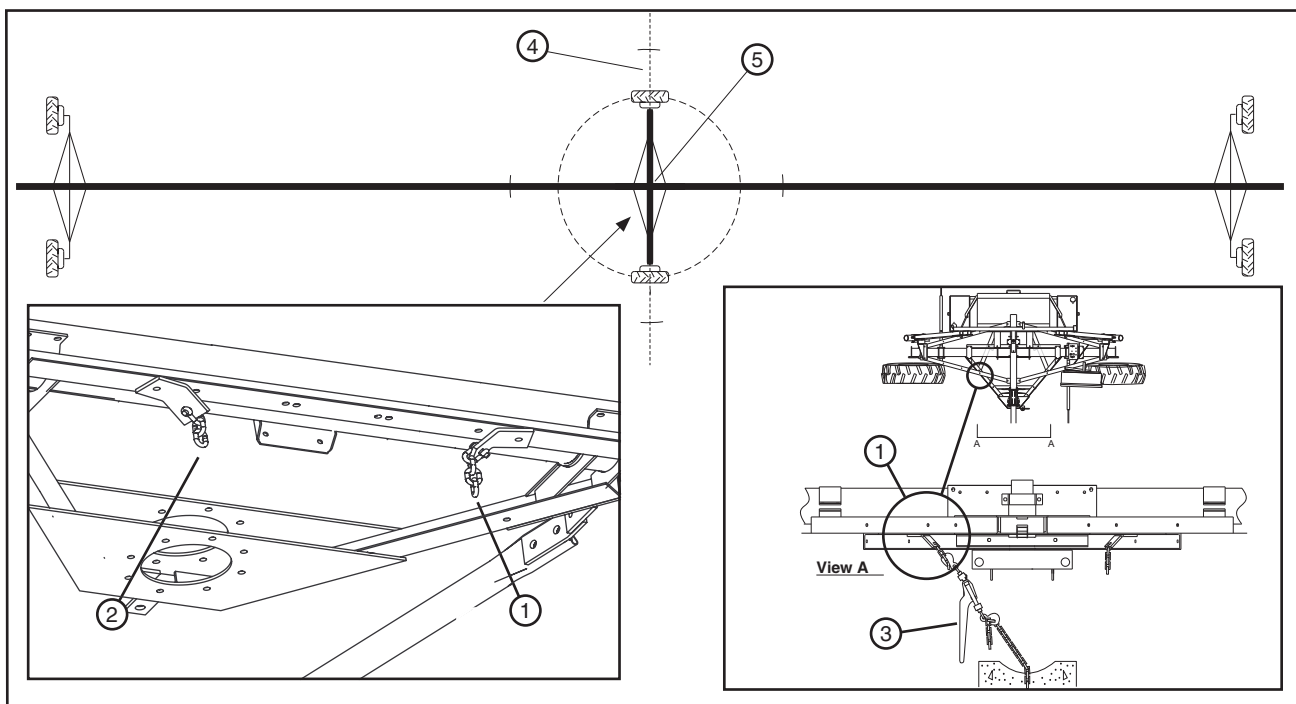

Figure 78-3 Concrete Anchor Method.  
1. Anchor Chain for Clockwise (CW) Rotation  
2. Anchor Chain for Counter-Clockwise (CCW) Rotation  
3. Load Binder (Handle Oriented Downward)  
4. Furrow  
5. Pivot Point

### Swing Around Option Preparing to Pivot

The following is a guide to preparing the Swing Around Linear for pivoting.

Prior to pivoting the machine do the following:

1. Position linear cart correctly over the pivot point. If the system has stopped at a point other than the desired, then adjust the end of hose stop post to the position required, then relocate the cart to the desired position.
2. Raise, fold and secure the furrow guidance arms up against the drive tower to prevent possible damage to the furrow guidance arms while pivoting the machine.
3. Disconnect the hose from the tee inlet and re-positioned away from the machine to prevent possible damage while pivoting the machine.
4. Remove the suction inlet from the elbow on the ditchfeed and re-position away from the machine to prevent possible damage while pivoting the machine
5. It is important that routine maintenance of the pivot area be performed. The pivot area must be kept clean of weeds or other debris.

### Classicplus Control Panel Pivoting Procedure

To pivot the span, position the machine correctly and follow all guidelines on the previous pages of this section. Then do the following:

1. At the control panel, switch the START/STOP rocker switch to the STOP position. See figure 79-1.
2. Switch the WATER ON/OFF rocker switch to the OFF position. See figure 79-1.

#### NOTE

•The Swing Around Linear should always be ran dry (without water) when pivoting or swinging the span around.

3. Switch the PIVOT/LINEAR rocker switch to the pivot mode. See figure 79-1.
4. Set the FORWARD/REVERSE switch for the desired direction of travel that the machine will move in when started. See figure 79-1.
5. Set the percent timer to the desired percentage. See figure 79-1.
6. Switch the START/STOP rocker switch to the START position, to start the machine in the pivot mode. See figure 79-1.
7. When the machine reaches the end of pivot zone, switch the START/STOP rocker switch to the STOP position. See figure 79-1.
8. Switch the PIVOT/LINEAR rocker switch to the linear mode. See figure 79-1.

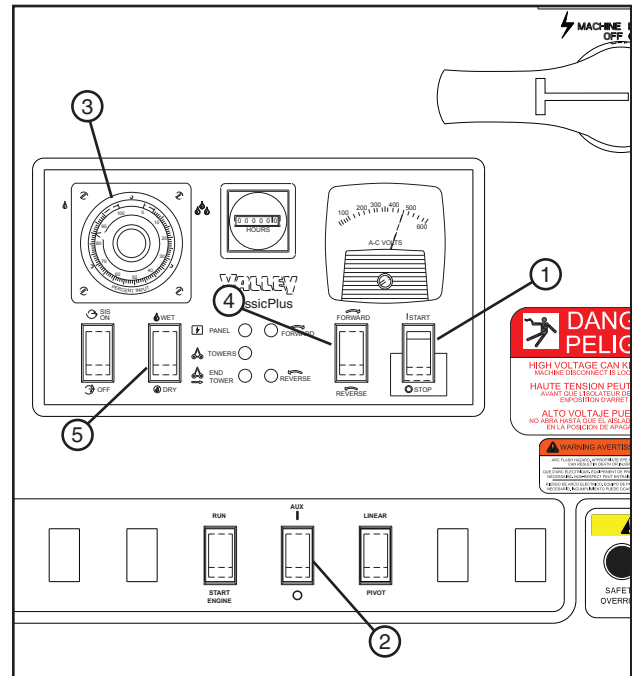



Figure 79-1 1. Start/Stop Switch 4. Forward/Reverse Switch  
2. Pivot/Linear Switch 5. Water ON/OFF switch  
3. Percent Timer

# OPERATION

## Open Delivery Swing Around Option AutoPilot Control Panel Pivoting Procedure

To pivot the span, position the machine correctly and follow all guidelines on the previous pages of this section. Then do the following:

1. At the control panel, press . See figure 80-1.

2. Press  to turn the Water OFF. See figure 80-1.

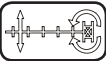
3. Press  and **2** to change the machine to the pivot mode. See figure 80-1.

4. Press the correct number key to select the pivot zone that the machine will be operating within.

Select a Zone 1=A, 2=B, 3=C 4=D. See figure 80-2.

5. Select the direction of movement for the span to pivot. See figure 80-2.

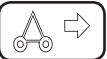
- Press  for reverse.

OR

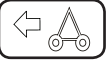
- Press  for forward.

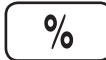
6. Press  to set the percent timer to the desired percentage. See figure 80-2.

7. Press  to start the machine in the pivot mode. See figure 80-3.

8. Press  to stop the machine at the end of the pivot zone. See figure 80-4.

9. Press  and **3** to return the machine to the linear mode. See figure 80-4.

### NOTE

- The Linear Swing Around should always be ran dry (without water) when pivoting or swinging the span around.

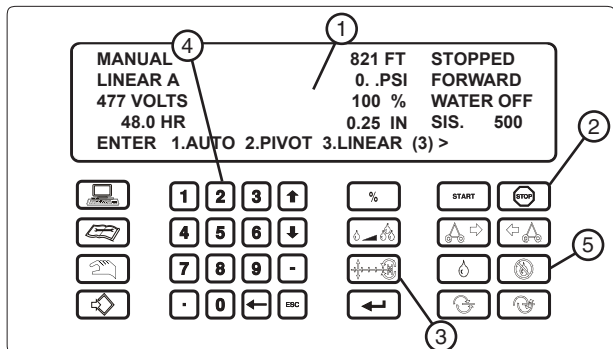

Figure 80-1 1. Control Panel Display. 2. Stop Key. 3. Pivot/Linear Key. 4. Numeric Key. 5. Water OFF Key.

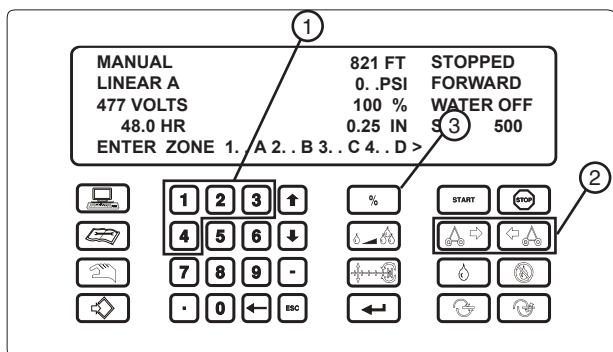

Figure 80-2 1. Numeric Keys 2. Direction Keys 3. Percent Key

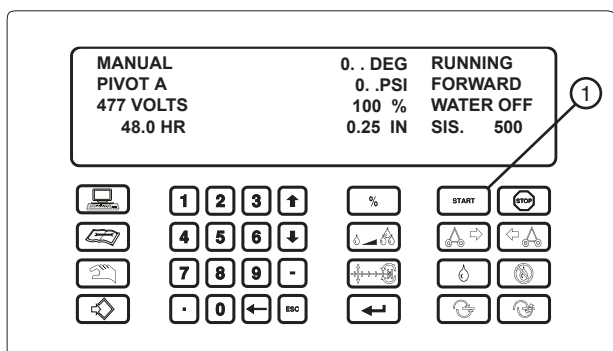

Figure 80-3 1. START key.

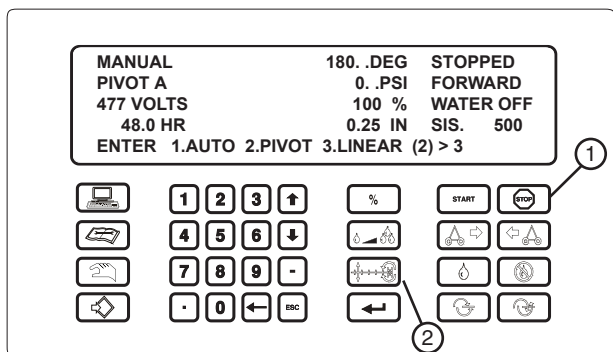

Figure 80-4 1. Stop Key 2. Pivot/Linear Key

## Open Delivery

### Towing Option

#### Preparing The Drive Units For Towing

This topic provides instruction on the preparation of the drive units for towing.

**REMEMBER: SAFETY FIRST – Operate according to the following procedures when towing and read all safety precautions in this manual.**

1. Position the machine in the tow lane. See figure 81-1.

### NOTE

- The tow lane should be flat and void of any crop rows.
- If towing on a side slope the machine may tend to shift down the hill due to gravitational pull.
- DO NOT tow across crop rows, ditches or rough terrain.

2. Turn the power off at the main disconnect and secure with a lock. See figure 81-2.

### WARNING

- NEVER ATTEMPT TO LIFT THE ENTIRE DRIVE UNIT AT ONE TIME.
- IF THE JACK BEGINS TO SLIP OR MOVE OUT OF POSITION, STOP RAISING THE DRIVE UNIT IMMEDIATELY, LOWER THE DRIVE UNIT AND REPOSITION THE JACK.

### NOTE

- Position the jack so it will not interfere with the rotation of the tire, wheel gearbox, swivel mount or swivel mount hardware.

3. The wheels on each drive unit must be turned into the tow position. Use a jack to lift one side of the drive unit until the tire is off of the ground. See figure 81-3.
4. Loosen the clamps securing u-joint shields in position. Slide all four u-joint shields away from the gearboxes.

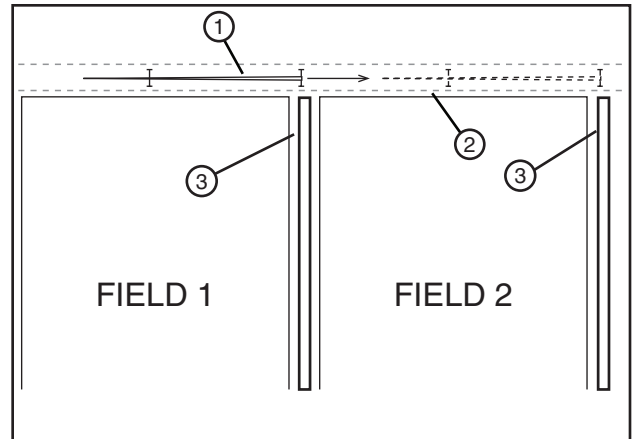

Figure 81-1 1. Machine  
2. Tow Lane



Figure 81-2

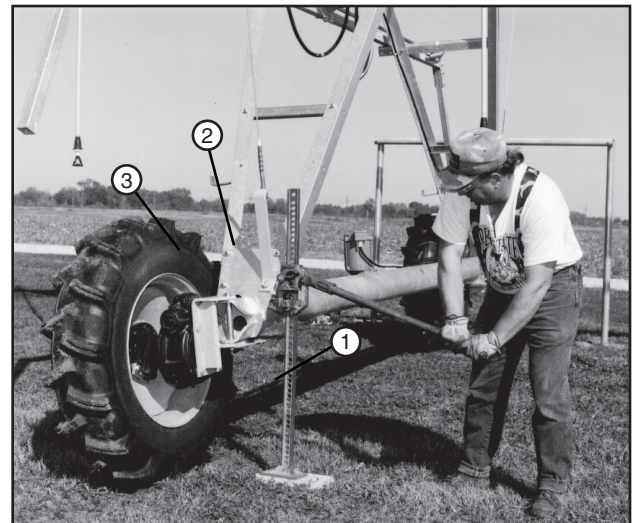

Figure 81-3 1. Jack  
2. Drive Unit  
3. Tire



# OPERATION

## Open Delivery

## Towing Option

### Preparing The Drive Units For Towing (Continued)

5. Remove lynch pin from retainer clip, then open retainer clip and pull the torque pin from axle torque arm behind gearbox hub and hub torque pin receiver. See figure 82-1.

6. Using a pry bar, push down on the steering arm to release it from the latch plate. Push the tire toward the tow position until steering arm is out of latch plate. See figure 82-2.

7. As the tire is turned into the tow position, support the drive shaft and use a small pry bar to separate the drive shaft u-joint half from the flex joint and wheel gearbox u-joint half.

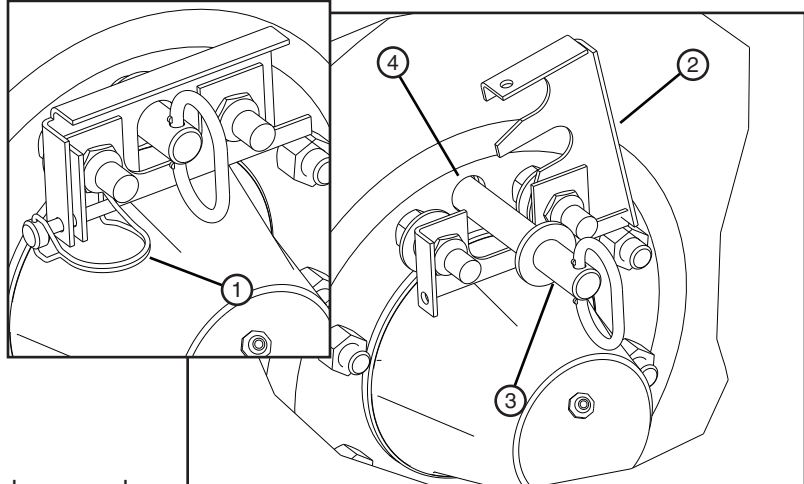

Figure 82-1 1. Lynch Pin 2. Retainer Clip 3. Torque Pin 4. Hub Torque Pin Receiver

After separating the u-joint, place the loose end of drive shaft in the drive shaft keeper. See figure 82-3.

8. If this is a TOWER drive unit, proceed to the FIXED TOW LINKAGE section.

If this is a CART drive unit, there are two(2) different types of towing linkage available for the cart drive unit, either Fixed or Steerable Tow Linkage.

- If the cart drive unit uses a tow link bar between the base beam and each steering arm to hold the tires in the tow position, proceed to the FIXED TOW LINKAGE section.
- If the cart drive unit uses tie rods between the tongue and each steering arm to provide steering at the cart end of machine, proceed to the STEERABLE TOW LINKAGE section.

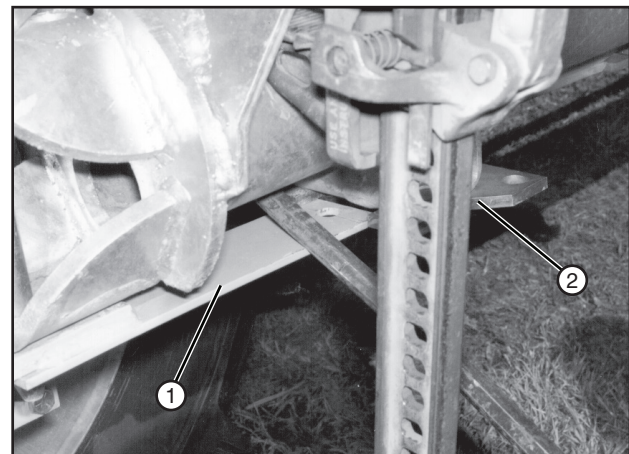

Figure 82-2 1. Steering Arm 2. Latch Plate

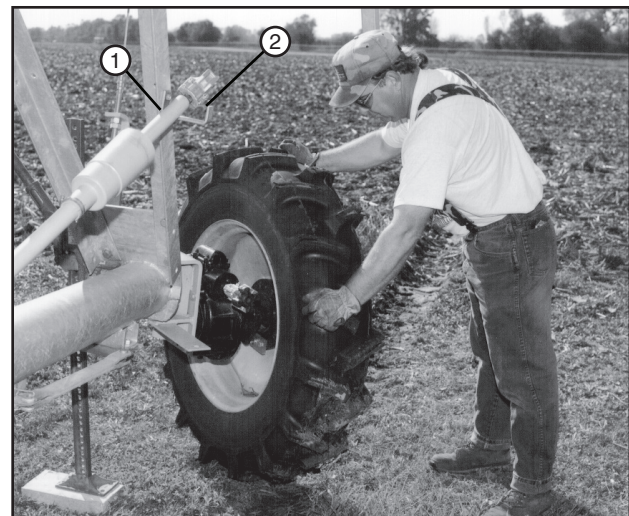

Figure 82-3 1. Drive Shaft 2. Drive Shaft Keeper

### Towing Option

#### Fixed Tow Linkage

Fixed tow linkage is available on all drive units including the cart drive unit. .

The fixed tow linkage uses a tow link bar between the base beam and steering arm to hold the tire in the tow position.

Use the following procedure to connect the fixed tow linkage.

1. Lift the carrier spring and release the tow link bar from the tow link carrier. See figure 83-1.
2. Position steering arm in tow link bar yoke, align holes, then attach steering arm to tow link bar with torque pin. Secure torque pin with lynch pin. See figure 83-2.
3. Lower the drive unit and remove the jack. The tire is now in the tow position
4. Repeat steps 3-10 for all other fixed tow position drive unit tires.
5. On the cart drive unit do the following:
  - Use the hand crank to raise the elbow.
  - Disconnect the Inlet Suction hose from the elbow inlet.
  - Attach the tongue to the hose pull frame with torque pin. See figure 83-3.

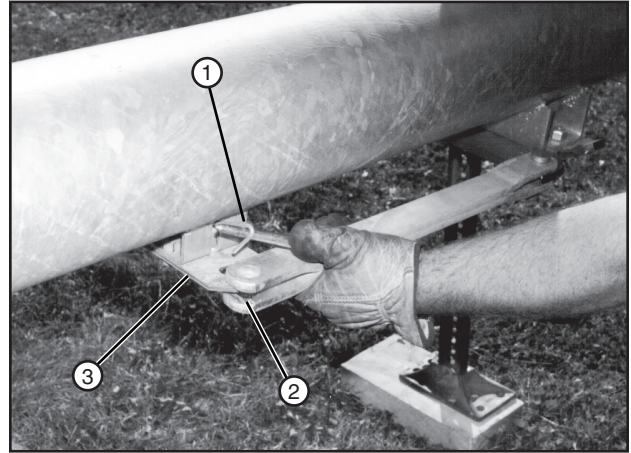

Figure 83-1 1. Carrier Spring 2. Tow Link Bar 3. Tow Link Carrier

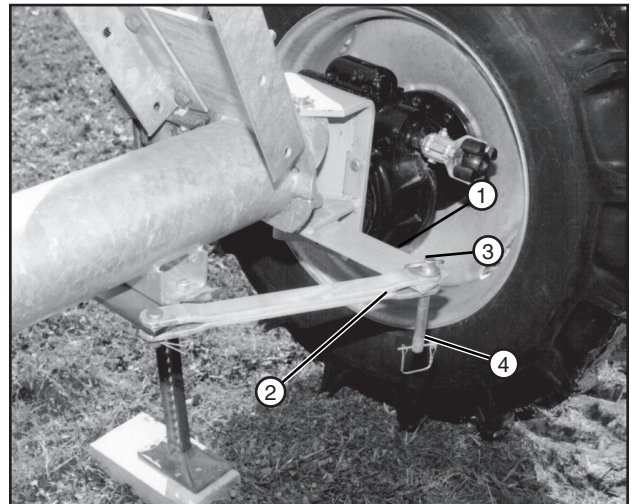

Figure 83-2 1. Steering Arm 2. Tow Link Bar Yoke 3. Torque Pin 4. Lynch Pin

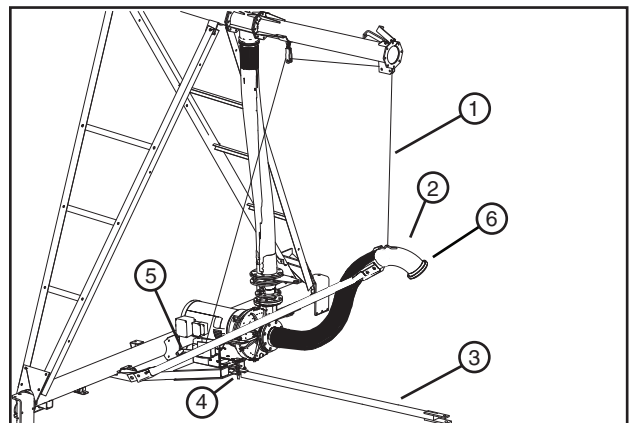

Figure 83-3 1. Lift Cable 2. Elbow Inlet 3. Tongue 4. Torque Pin 5. Cable Lift Handle 6. Disconnect Point

# OPERATION

## Open Delivery

## Towing Option

## Steerable Tow Linkage

Steerable tow linkage is only available on the cart drive unit.

Steerable tow linkage uses tie rods between the tongue and each steering arm to provide steering at the cart end of machine.

Use the following procedure to connect the steerable tow linkage.

1. Attach tongue with tie rods to the hose pull frame with torque pin. See figure 84-1.
2. Connect end of tie rod to steering arm with one clevis pin and hair pin. See figure 84-2.
3. Lower the drive unit and remove the jack. The tire is now in the tow position.
4. Repeat steps 3-10 for the other steerable tow drive unit tire.
5. On the cart drive unit do the following:
  - Use the lift cable to lift the elbow inlet up. See figure 84-3.
  - Disconnect the inlet suction hose from the elbow inlet to prevent damage. See figure 84-3.

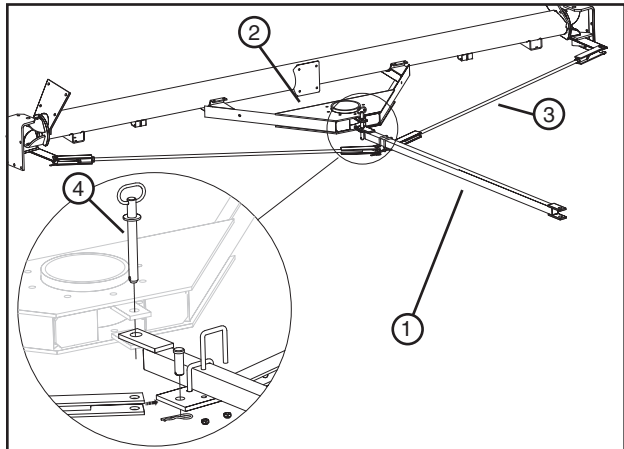

Figure 84-1 1. Tongue 2. Hose Pull frame 3. Tie Rod 4. Torque Pin

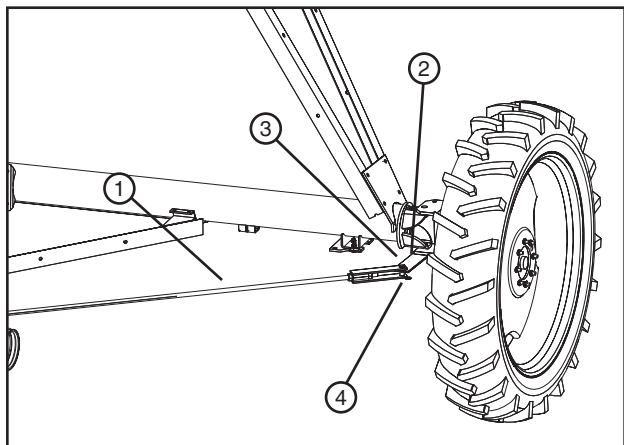

Figure 84-2 1. Tie Rod 2. Steering Arm 3. Clevis Pin 4. Hair Pin

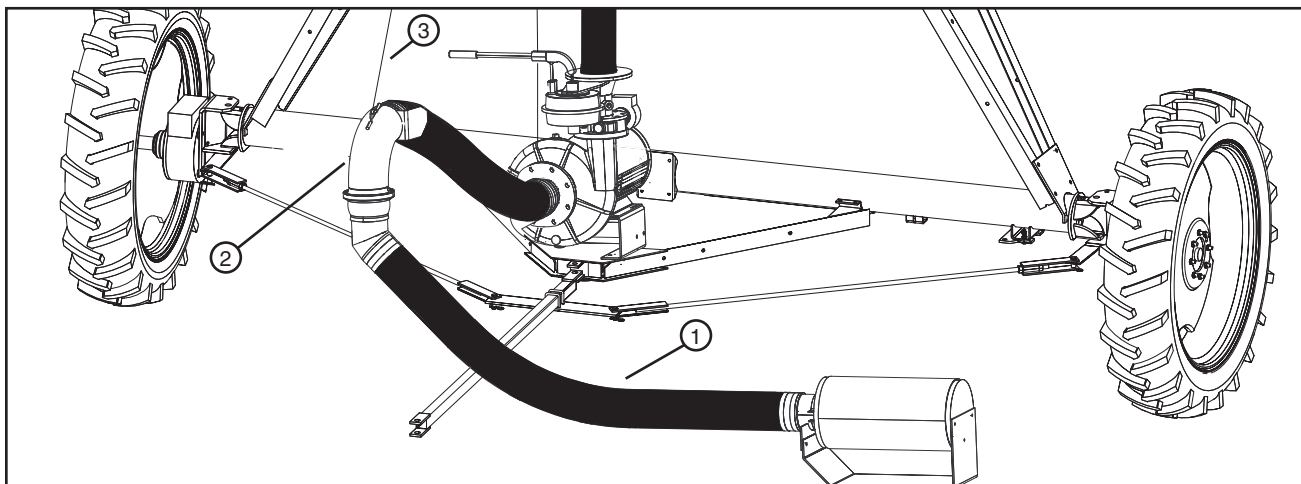

Figure 84-3 1. Inlet Suction Hose 2. Elbow Inlet (Inlet in Up Position) 3. Lift Cable



### Towing Option

#### Towing The 2 Wheel Linear

This topic provides instruction on towing the 2 Wheel Linear.

**SAFETY FIRST - Operate according to the following procedures when towing and read all safety information in this manual.**

1. Position the machine in the tow lane. See figure 85-1.
2. Prepare the drive units for towing. See Preparing the Drive Units For Towing in the Towing Option Section.
3. Make sure the hose is disconnected from the elbow inlet.
4. Attach the tongue to the towing unit. See figure 85-2.
5. After the cart and drive unit have been prepared for towing, begin towing the machine in a slow, gradual manner to the next location.
6. After reaching the next location, disconnect the tongue from the hose pull frame and the towing unit. Also disconnect tie rods from steering arms if using the steerable tow linkage.
7. Prepare the drive units for operation. See Preparing The Drive Units For Operation in the Towing Option Section. After preparing the drive units for operation the machine is ready for use.

### CAUTION

- TO REDUCE THE POSSIBILITY OF STRUCTURAL DAMAGE :
- IF TOWING ON A SIDE SLOPE THE MACHINE MAY TEND TO SHIFT DOWN THE HILL DUE TO GRAVITATIONAL PULL.
- DO NOT TOW ACROSS CROP ROWS, DITCHES OR ROUGH TERRAIN.
- DO NOT JERK THE MACHINE AT ANYTIME WHILE TOWING.
- DO NOT TOW THE MACHINE MORE THAN 2 MILES PER HOUR MAXIMUM.
- ALWAYS TOW THE MACHINE IN A STRAIGHT LINE.
- NEVER ATTEMPT TO TURN THE MACHINE WHEN TOWING.
- NEVER ATTEMPT REVERSING OR BACKING THE MACHINE INTO POSITION.

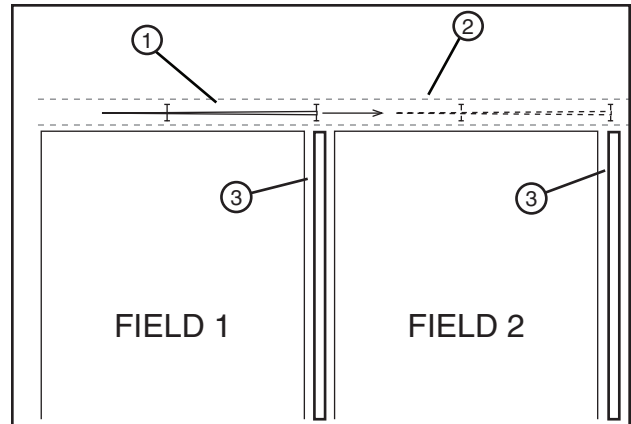

Figure 85-1 1. Machine 2. Tow Lane 3. Ditch

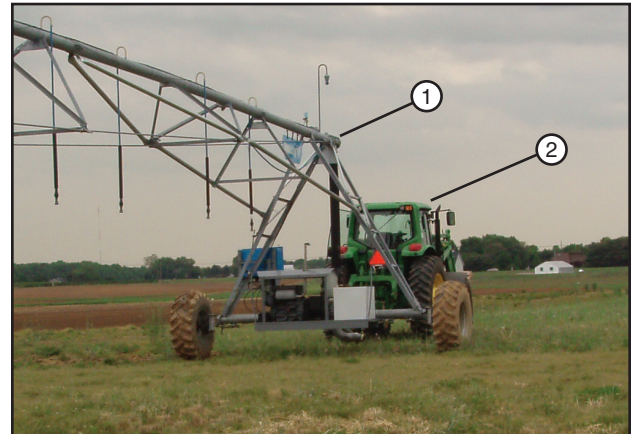

Figure 85-2 1. 2 Wheel Linear 2. Towing Unit

# OPERATION

## Open Delivery

## Towing Option

### Preparing The Drive Units For Operation

This topic provides instruction on the preparation of the drive unit for operation.

**REMEMBER: SAFETY FIRST – Operate according to the following procedures when towing and read all safety precautions in this manual.**

#### **⚠ WARNING**

- NEVER ATTEMPT TO LIFT THE ENTIRE DRIVE UNIT AT ONE TIME.
- IF THE JACK BEGINS TO SLIP OR MOVE OUT OF POSITION, STOP RAISING THE DRIVE UNIT IMMEDIATELY, LOWER THE DRIVE UNIT AND REPOSITION THE JACK.

#### **NOTE**

- POSITION THE JACK SO IT WILL NOT INTERFERE WITH THE ROTATION OF THE TIRE, WHEEL GEARBOX, SWIVEL MOUNT OR SWIVEL MOUNT HARDWARE.

1. Use a jack to lift one side of the drive unit until the tire is off of the ground. See figure 86-1.
2. For the cart drive unit do one of the following:
  - If the steerable tow linkage was used continue with step 5.
  - If fixed tow linkage was used continue with step 3.
3. Remove the lynch pin from the torque pin, then remove the torque pin and disconnect the tow link bar from the steering arm. See figure 86-1.
4. Rotate the tow link bar into the tow link carrier until the carrier spring latches into the hole in the tow link bar. See figure 86-2.
5. As the tire is turned to the operating position, align the drive shaft u-joint half with the flex joint and wheel gearbox u-joint half.

Continue pushing the tire toward the operating position with enough force to push the gearbox u-joint half over the flex joint and latch the steering arm in the latch plate.

6. Make sure the steering arm is latched in the latch plate. See figure 86-3.

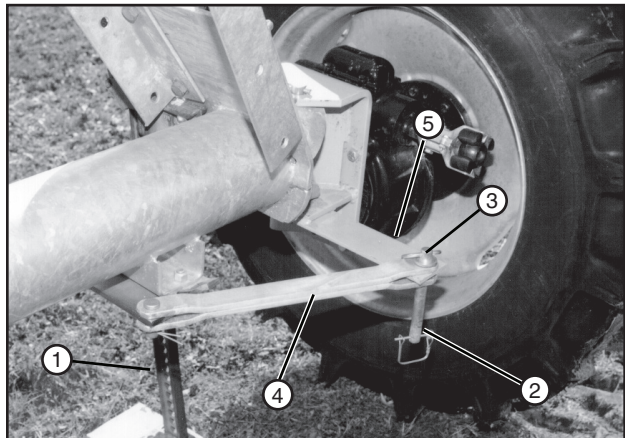

Figure 86-1 1. Jack 2. Lynch Pin 3. Torque Pin 4. Tow Link Bar 5. Steering Arm

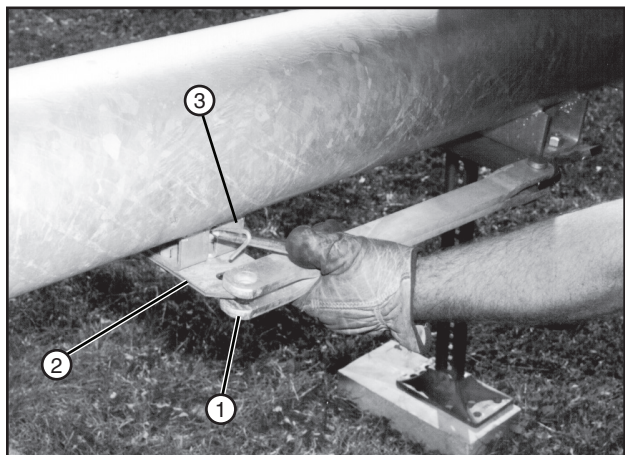

Figure 86-2 1. Tow Link Bar 2. Tow Link Carrier 3. Carrier Spring

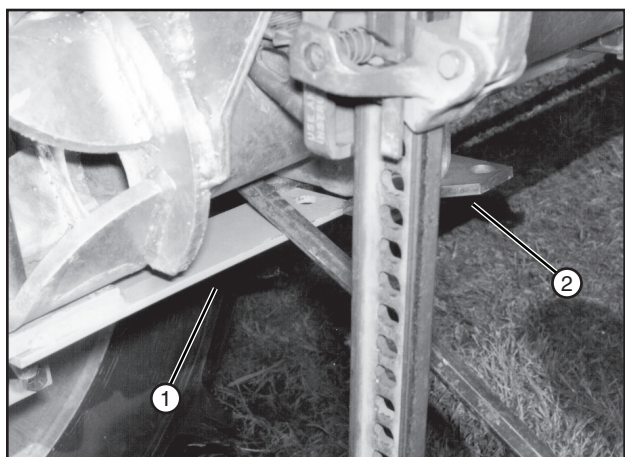

Figure 86-3 1. Steering Arm 2. Latch Plate

### Towing Option

### Preparing The Drive Units For Operation (Continued)

- Slide the U-joint shield over the U-joint and position approximately 1/4 in away from touching the gearbox. Secure the U-joint shield to the drive shaft shield with a clamp. See figure 87-1.

Repeat the procedure for all U-joint shields.

- Rotate the tire until the hole in the hub torque pin receiver is aligned with the hole in the axle torque arm. Install the torque pin and close the retainer plate. Secure the retainer plate to the retainer clip with the lynch pin. See figure 87-2.

- Lower the drive unit and remove the jack. The tire is now in the OPERATING position. See figure 87-3.

- Repeat steps 1-8 for all other drive unit tires.

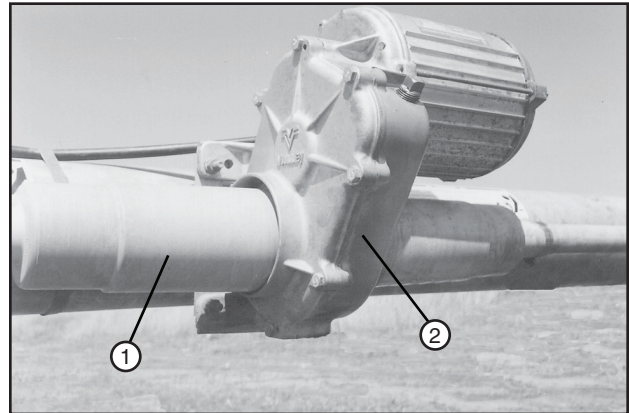

Figure 87-1 1. U-Joint Shield  
2. Gearbox

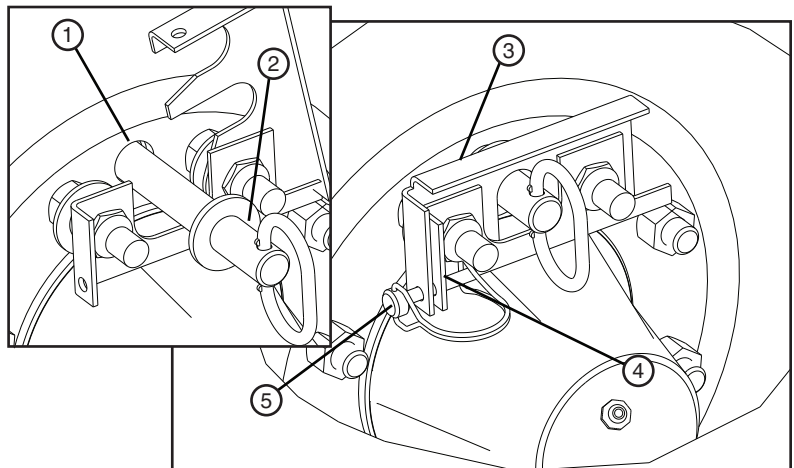

Figure 87-2 1. Hub Torque Pin Receiver 4. Retainer Clip  
2. Torque Pin 5. Lynch Pin  
3. Retainer Plate



Figure 87-3 1. Tire Shown In Operating Position



# MAINTENANCE

## Safety

### **DANGER**

- THE CONTROL PANEL CONTAINS HIGH VOLTAGE! 480 VOLTS CAN KILL.
- ALWAYS DISCONNECT ELECTRICAL POWER BEFORE SERVICING OR PERFORMING MAINTENANCE TO THE MACHINE.
- TESTING AND TROUBLESHOOTING SHOULD BE PERFORMED ONLY BY AN AUTHORIZED VALLEY DEALER.
- ALWAYS REPLACE ANY GUARDS OR SHIELDS THAT ARE REMOVED FOR PERFORMING MAINTENANCE.

## Disconnect All Power

Before performing service or maintenance on any part of the machine, follow the MINIMAL LOCKOUT/TAGOUT PROCEDURE located in the SAFETY section of this manual and do the following:

1. SHUT OFF and LOCK the public power service disconnect to the irrigation machine. See figure 88-1.

FILL OUT the blue (OSHA safety color code) tag and attach to the disconnect after locking. See figure 88-1.

2. SHUT OFF and lock the control panel main power disconnect. See figure 88-2.

FILL OUT the blue (OSHA safety color code) tag and attach to the disconnect after locking. See figure 88-2.

### **DANGER**

- BE AWARE OF HIGH WATER PRESSURE. TURN OFF THE PUMP AND ALLOW THE MACHINE TO DRAIN COMPLETELY BEFORE REPAIRING OR PERFORMING MAINTENANCE TO THE MACHINE.

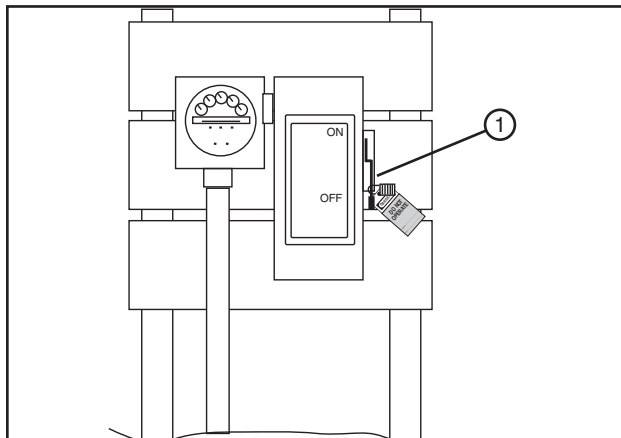

Figure 88-1 1. Public Power Service Disconnect

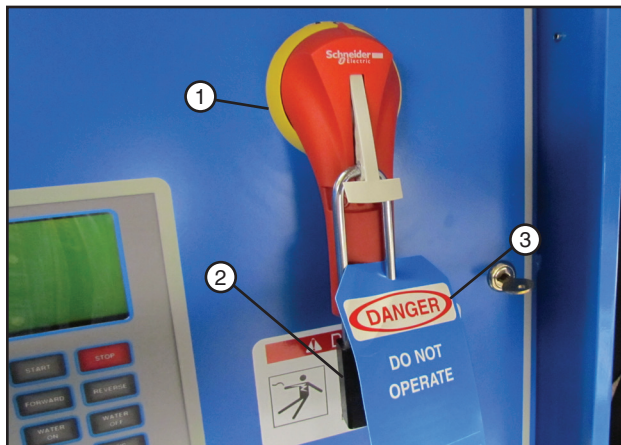

Figure 88-2 1. Main Disconnect  
2. Lock  
3. Blue Tag

## Wheel Gearbox

### NOTE

- After the first operating season, change the oil in all of the wheel gearboxes.
- After the first oil change, change the wheel gearbox oil every third year or 3000 operating hours, whichever occurs first.
- At the end of each operating season, drain the wheel gearboxes of any condensation or contaminated oil that may have accumulated in the gearbox and refill to its normal level.

3. Remove the drain plug from the bottom of the wheel gearbox and drain the oil into a container. See figure 89-1.
4. Install the drain plug after draining oil.
5. Clean all of the dirt away from the expansion chamber cap and remove the expansion chamber cap. Do not allow dirt to fall into the gearbox when removing the cap. See figure 89-2.
  - Make sure the vent holes on each side of the expansion chamber cap are open and unobstructed.

### NOTE

- Use only Valley Gear Lube. Other brands of lubricants may contain corrosive extreme pressure additives, which may damage bronze worm gears.

VALLEY GEAR LUBE	
Part No.	Description
0996557	55 Gallons
0996558	16 Gallons
0996559	5 Gallons
0996560	2 1/2 Gallons

6. Fill the wheel gearbox with Valley Gear Lube. The capacity is approximately 3.9 quarts (3.7 l).
  - Fill gearbox to the top of worm gear shaft or remove the check plug and fill until the oil begins to flow out of the check plug hole. See figure 89-3.
7. Install the expansion chamber cap after refilling the gearbox. Secure with original hardware and torque to 8 lb-ft (10.8N·m).

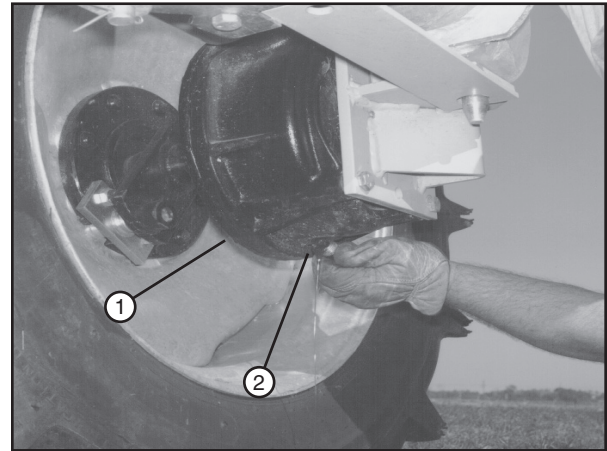

Figure 89-1 1. Wheel Gearbox  
2. Drain Plug

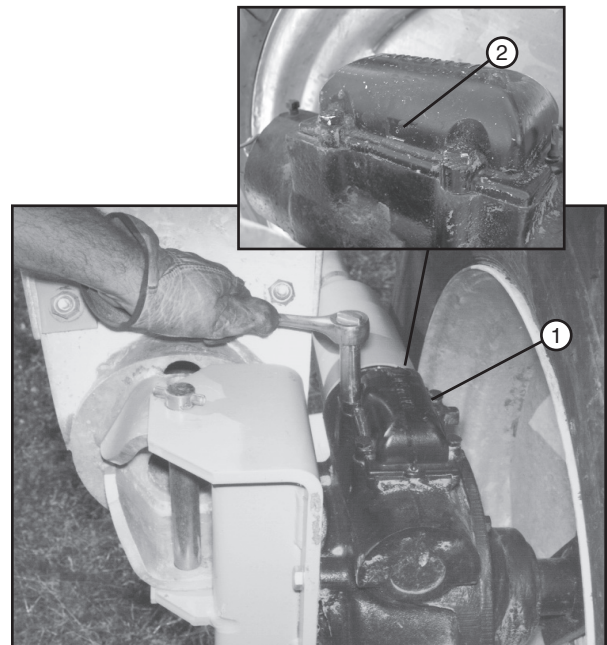

Figure 89-2 1. Expansion Chamber Cap  
2. Vent Hole

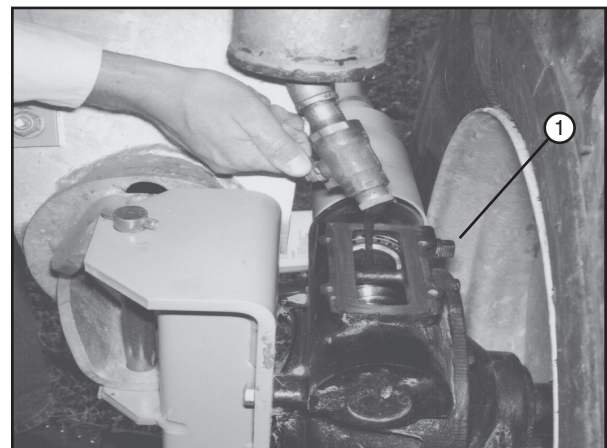

Figure 89-3 1. Check Plug

# MAINTENANCE

## Center Drive Gearmotors

### Helical Gearmotor

After EACH season of operation, change the oil in all of the helical gearmotor gearboxes.

1. Remove the drain plug and the fill plug. Drain the oil and install the drain plug. See figure 90-1.

### NOTE

- Use only Valley Gear Lube. Other brands of lubricants may contain corrosive extreme pressure additives, which may damage bronze worm gears.

VALLEY GEAR LUBE	
Part No.	Description
0996557	55 Gallons
0996558	16 Gallons
0996559	5 Gallons
0996560	2 1/2 Gallons

2. Fill the gearbox 1-7/8 in (48 mm) from the bottom of fill plug hole with Valley Gear Lube. The capacity of the gearbox is approximately 44 oz (1.3 liter). See figure 90-2.

### NOTE

- OIL LEVEL SHOULD BE 1-7/8 IN (48 MM) BELOW FILL PLUG WHEN FULL.

### WARNING

- INPUT SEAL FAILURE CAN OCCUR IF OIL CAPACITY IS EXCEEDED.

## Worm Gearmotor

After EACH season of operation, change the oil in all of the worm gearmotor gearboxes.

1. Remove the drain plug and the fill plug. Drain the oil and install the drain plug. See figure 90-3.

### NOTE

- Use only Valley Gear Lube. Other brands of lubricants may contain corrosive extreme pressure additives, which may damage bronze worm gears.

VALLEY GEAR LUBE	
Part No.	Description
0996557	55 Gallons
0996558	16 Gallons
0996559	5 Gallons
0996560	2 1/2 Gallons

2. Fill the gearbox to within 1/2 in (12.7 mm) of the bottom of the fill plug hole with Valley Gear Lube. The capacity of the gearbox is approximately 1 quart (0.9 liter). See figure 90-3.

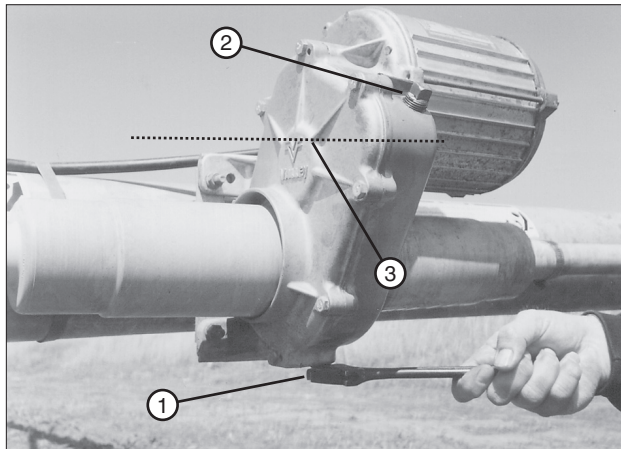

Figure 90-1 1. Drain Plug  
2. Fill Plug  
3. Approx. Oil Level

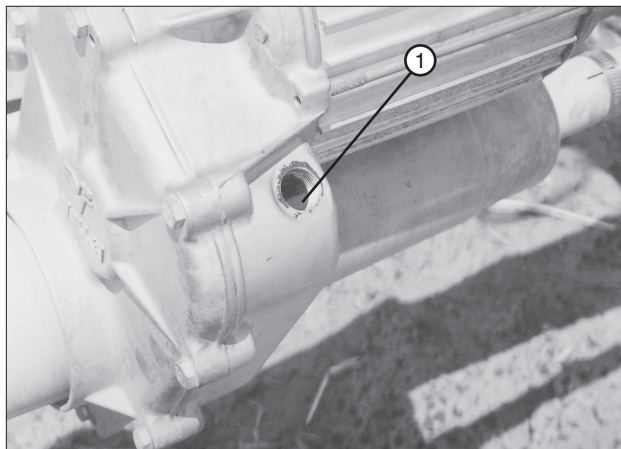

Figure 90-2 1. Bottom Of Fill Plug Hole

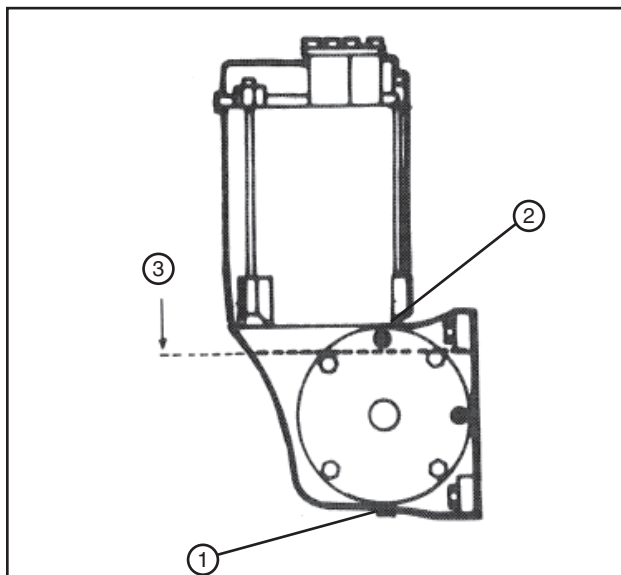

Figure 90-3 1. Drain Plug 2. Fill Plug 3. Oil Level

## Tire And Wheel

### Towable Hub Lubrication

The towable hubs should be greased at least once a year with water resistant lithium based grease, preferably in the fall.

This must be done whether the pivot has been towed or not during the season.

The grease fitting is located on the end of hub. Refill the bearing cavity using a grease gun. See figure 91-1.

When the cavity is full, grease will cream around the seal area. Greasing the hub will also help push out any water which may have accumulated in the hub.

### Wheel Lug Nut Torque

Wheel lug nuts should be torqued to 125 lb-ft (169.47N·m). See figure 91-1.

Check the wheel lug nut torque annually, pre-season; at spring start-up.

### Tire Pressures

Proper tire pressure is important! Operating with low tire pressure will damage the tires and the drive train.

Check tire pressure several times a year:

- Pre-season: At spring start-up.
- During-season: Check tire pressure monthly.
- Post-season: When performing fall winterization.

For the correct tire pressure refer to the decal on the rim or the tire pressure chart. See figure 91-2.

### **⚠ WARNING**

- **TIRES ARE SHIPPED AT A PRESSURE OF 30 TO 35 PSI (206 TO 241 KPA).**
- **BE SURE THE TIRES HAVE BEEN DEFLATED TO THE CORRECT PRESSURE (SHOWN ON DECAL) BEFORE THE TIRE IS USED.**

### **NOTE**

- **When replacing tires be sure the ply rating of the new tire is equal to or greater than the ply rating of the old tire.**

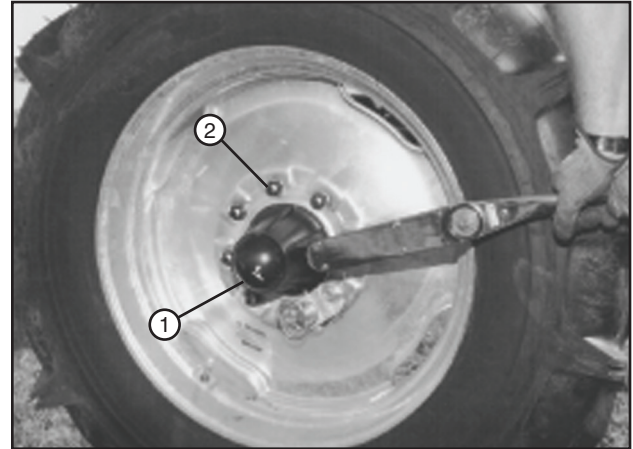

Figure 91-1 1. Grease Fitting  
2. Wheel lug nut

### TIRE PRESSURE CHART

Hose Drag Cart		
Tire Size	Pounds per Square Inch	Kilo pascal
(Inches)	(PSI)	(kPa)
14.9 X 24 Float Tire	18	124
14.9 X 24 Turf Tire	18	124
Span Drive Units		
Tire Size	Pounds per Square Inch	Kilo pascal
(Inches)	(PSI)	(kPa)
11.2 X 38 Tire	23	152
14.9 X 24 Float Tire	18	124
14.9 X 24 Turf Tire	18	124
16.9 X 24 Float Tire	16-18*	110-124
16.9 X 24 Turf Tire	16-18*	110-124

\*Tire pressure may be reduced to 16 psi (110 kPa) for increased flotation.

Figure 91-2



# MAINTENANCE

## Centrifugal Pump Lubrication

The following are general centrifugal pump lubrication recommendations and may not apply to the centrifugal pump included with this irrigation machine. Always refer to the centrifugal pump Owner's Manual or centrifugal pump manufacturer for the proper lubricant, lubrication frequency and lubrication procedures.

### Grease Lubricated Frames

Use Lithium based grease equivalent to one of the following manufacturer's products:

G.E. Long Life Grease No. D682C5

Mobil Mobilux No. EP2

Shell Alvania EP2

Texaco Multifak No. 2

When adding grease be sure that grease fittings and end of grease gun are clean. See figure 92-1.

Use a hand operated grease gun only.

Refer to the table below for general lubrication frequency.

	Frame Size		
	2-5-11 EM309	6-7-8-16 60B4 though 68B4	10-12 18-18D
Total Running Time	2<000 hours	1,500 hours	1,000 hours
8-Hour Day Service	36 weeks	27 weeks	18 weeks
24-Hour Day Service	12 weeks	9 weeks	6 weeks
	3 pumps	6 pumps	12 pumps

### Run-Dry Reservoirs

Use an oil or fluid equivalent to one of the following manufacturer's products:

Chevron Turbine Oil GST 32

Transmission Fluid

Hydraulic Fluid

Royal Purple Barrier Fluid FDA 22

Synthetic White Oil 22

Fill and maintain the reservoir fluid level up to the middle of the top sight glass. See figure 92-1.

When filling the reservoir with fluid, be sure the air has been purged out of the upper circulation hose to reduce the possibility of vapor lock.

Change the reservoir oil every 1000 hours or once a year.

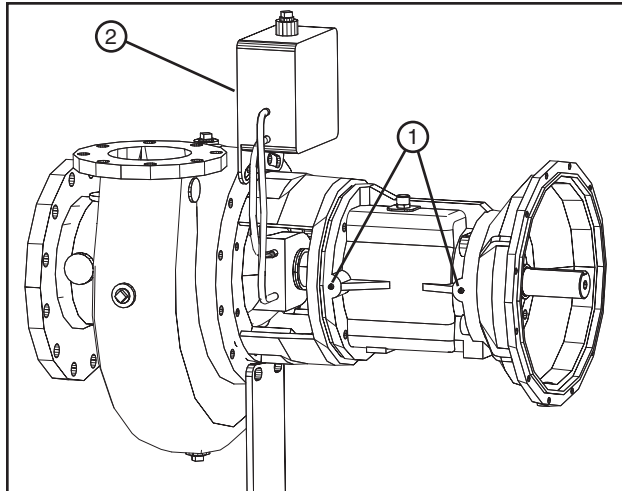

Figure 92-1 1. Grease Fitting  
2. Run-Dry Reservoir

## Furrow

The furrow must be maintained perfectly straight and unobstructed. The skid must slide in the furrow at a minimum depth of 3 in (75 mm) and a maximum of 6 in (150 mm). See figure 93-1.

The furrow guidance arm pivot points must be aligned with the furrow and the furrow guidance arm neutral position must be adjusted so that it is straight in line with the furrow guidance arm pivot point.

### WARNING

- NEVER TRY TO REPOSITION THE SYSTEM WHEN THERE ARE ESTABLISHED WHEEL TRACKS.

A three foot wide path on each side of the furrow must be kept clear of any obstructions that could prevent the system guidance hardware from functioning properly.

This path should have no parallel or perpendicular ridges or furrows through it.

## Furrow End of Field Shutdown

An optional method of providing an additional end of field shutdown is to place an angle in the furrow where you want the system to stop.

The furrow must be angled away from the drive unit enough that when the leading skid has traveled forward 10 ft (3.05 m) it has angled over 2 ft (0.61 m). See figure 93-2.

### CAUTION

- DO NOT ALLOW THE STRAIGHT PORTION OF THE FURROW TO GO BEYOND WHERE THE ANGLED END OF THE FIELD STOP FURROW IS PLACED.

### NOTE

- If either skid gets out of the furrow it will cause the system to shut down after the furrow guidance arm moves approximately 18 in (457 mm) out of alignment with the furrow guidance arm pivot point.

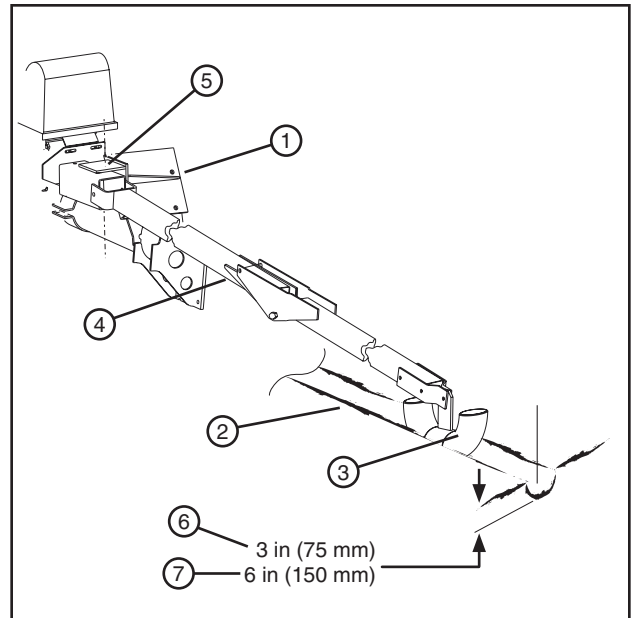

Figure 93-1 1. Drive Unit Side 5. Guidance arm pivot point  
2. Furrow 6. Minimum depth  
3. Skid 7. Maximum depth  
4. Guidance arm

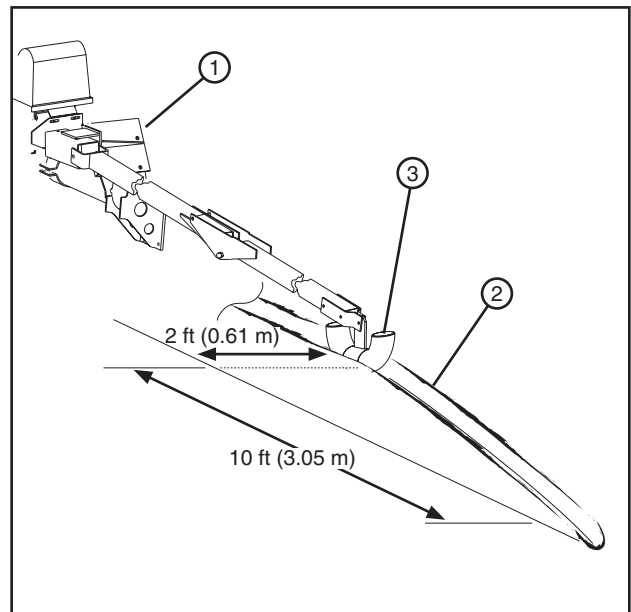

Figure 93-2 1. Drive Unit Side  
2. Furrow  
3. Skid

# MAINTENANCE

## Cart Path

The cart path must be kept clean and free of debris that may damage tires, hoses, or the linear machine.

- To reduce the possibility of structural damage to the irrigation machine, the cart path should always be graded flat and level so that the cart will not tip to either side as it travels down the cart path. The cart path should not have a crown or be graded at an angle. Structural damage to the irrigation machine may result.
- When changing hoses, always disconnect and drain the hose at the pipe line valve before disconnecting the hose from the cart to prevent water puddles from forming on the cart path.
- Do not allow wheel tracks to form on the cart path. The presence of wheel tracks in the cart path may cause inconsistent steering and unplanned machine stoppage. If left in a state of disrepair, wheel tracks can cause structural damage to the irrigation machine.

## Barricade

Maintain the barricade structure and area.

Inspect the barricade structure for failure and tighten any loose hardware completely.

Ensure that the actuator arm contacts the tripping structure. Under certain conditions, soil may build up in the wheel track resulting in a ramp effect. This may allow the actuator arm to go over the top of the structure which trips the actuator arm. See figure 94-1.

Should this happen, the machine will not stop but continue to move and can result in damage to the machine. Remove any build up of soil in the barricade area.

## Wheel Tracks

It is important to maintain wheel tracks. See figure 94-2.

- Wheel track depths must not exceed 4 in (100 mm).
- Wheel track depth can be controlled by using track fillers, tillers, discs, or flotation tires.

## Engine/Generator

Refer to the Owner's Manual supplied with engine/generator for specific details on maintenance, operation, and winterizing of the engine/generator.

### CAUTION

- A PARTIALLY FILLED FUEL TANK WILL PERMIT CONDENSATION WHICH WILL CONTAMINATE THE FUEL AND ACT TO DAMAGE THE INJECTION PUMP AND INJECTORS.

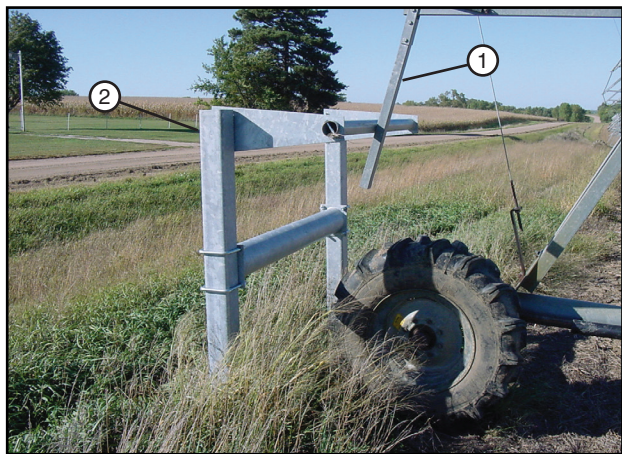

Figure 94-1 1. Actuator arm  
2. Barricade



Figure 94-2 1. Wheel Track  
2. Drive Unit

## Span Safety Box Cable Tension Adjustment

1. Check safety cable tension.
  - Use a truss spreader part number 9360055 to check the cable tension. The truss spreader is 115 in (292 cm) long and weighs 23.4 lb (10.6 kg).
2. Position the truss spreader across the safety cables at approximately 58 in (147 cm) from the alignment mounting bracket. See figure 95-1.
3. Hold and support the truss spreader across the safety cables and measure the distance from the truss spreader to the span pipe. This is the ORIGINAL measurement. See figure 95-1.
4. Lower the spreader angle onto the safety cables and allow the safety cables to support the full weight of spreader angle.

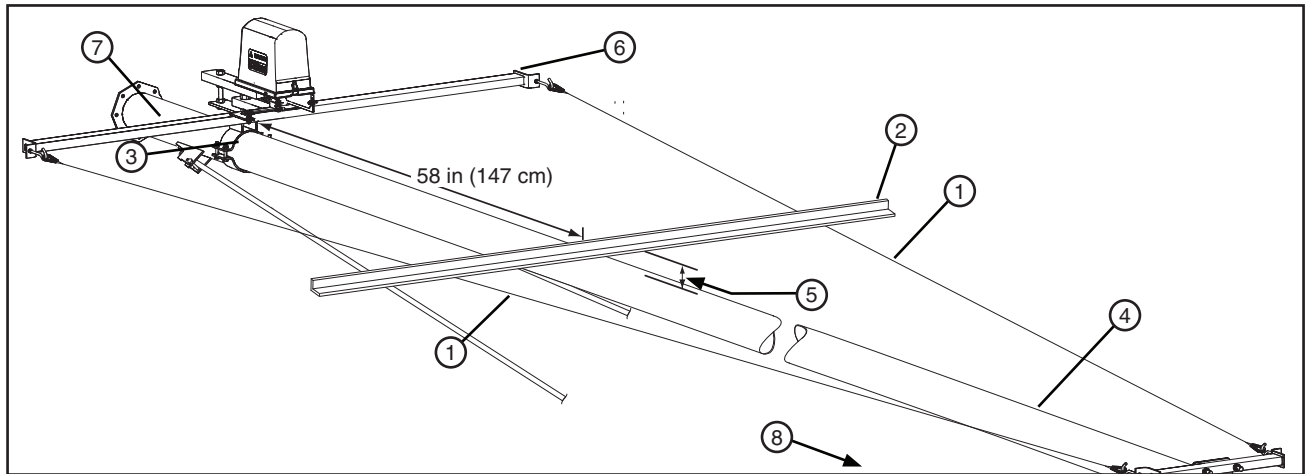

Figure 95-1 1. Safety Cable 2. Truss Spreader 3. Alignment Mounting Bracket 4. Span Pipe 5. Original Measurement 6. "T" Bar 7. Cart End of Span 8. Drive Unit End of Span

5. Measure the distance from the spreader angle to the span pipe. This is the DEFLECTED measurement.
  - The full weight of the spreader angle should deflect the safety cables downward approximately 1-3/4 in to 2 in (41 mm to 51 mm) when the DEFLECTED measurement is compared to the ORIGINAL measurement. Adjustment of deflection is made at the fixed end cable mount hook bolts. See figure 95-2.

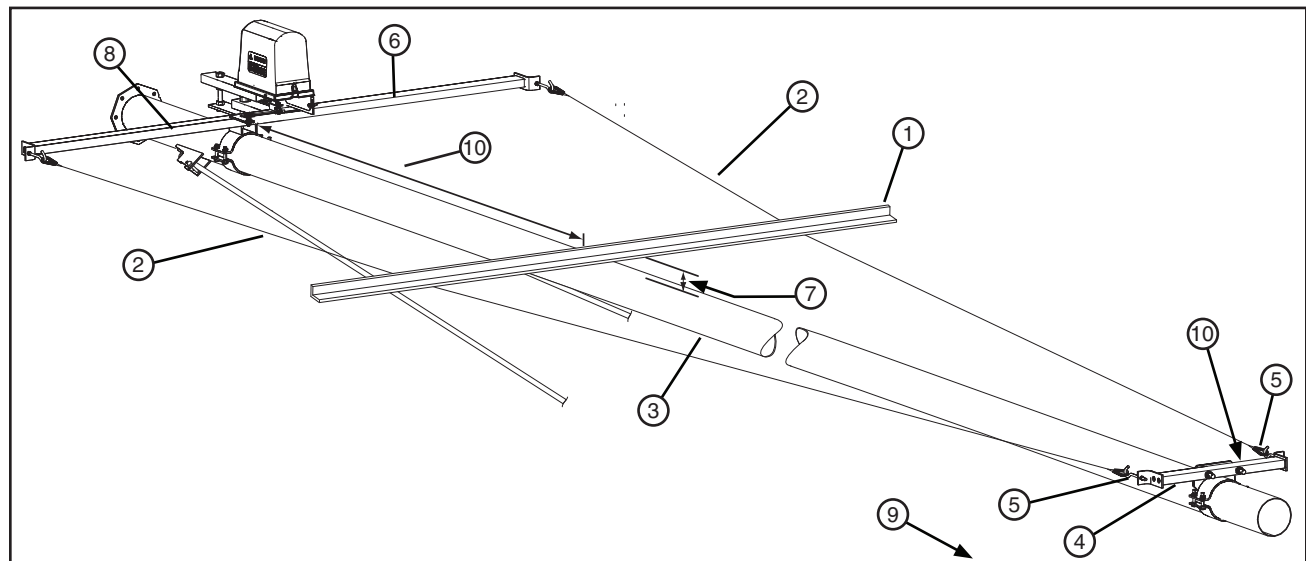

Figure 95-2 1. Spreader Angle 2. Safety Cable 3. Spreader Angle 4. Safety Cable 5. Hook Bolt 6. "T" Bar 7. Deflected Measurement 8. Cart End 9. Drive Unit End 10. 58 in (147 cm) 11. Fixed End Cable Mount

# MAINTENANCE

## Span Safety Box Cable Adjustment

- Adjust the fixed end cable mount hook bolts until both the proper deflection of safety cable is achieved and the "T" bar is perpendicular (90 degrees) to the span pipe. See figure 96-1.
- After adjustment, tighten all hook bolt hardware completely.

## Side Inlet Elbow Adjustment

To insure that the swivel inlet elbow works correctly when the machine is reversed the inlet elbow angle must be angled away from the cart at approximately 10 degrees. See figure 96-2

To Adjust the side inlet elbow angle do the following:

- Loosen jam nuts on 1/2 in x 3 in cap screw at each stop bracket
- Set the side inlet elbow in one direction so that it angles away from the cart at approximately 10 degrees.
- Adjust 1/2 in x 3 in cap screw until the head contacts the stop tab on inlet elbow, then tighten the jam nuts.
- Repeat steps 2 and 3 for the other direction.

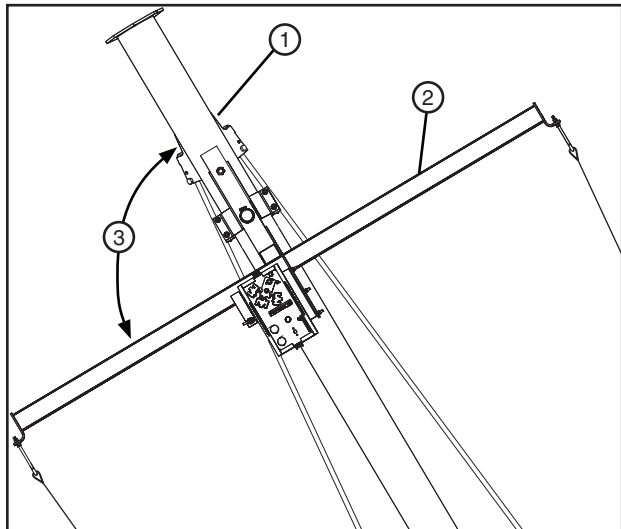

Figure 96-1 1. Span Pipe  
2. "T" Bar  
3. 90 Degrees

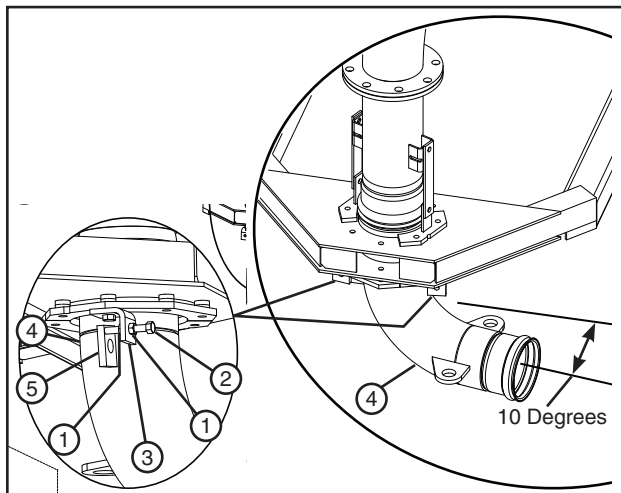

Figure 96-2 1. Jam Nut 4. Side Inlet Elbow  
2. 1/2 in x 3 in Cap Screw 5. Stop Tab  
3. Stop Bracket

## Poly Hose Repair

Hoses should be repaired as soon as possible after damage is discovered to prevent further deterioration.

### NOTE

•Pin holes in the hose should be marked with a quick burst of bright colored spray paint while there is pressure in the line to assist in locating the hole later for repair.

Large tears or cuts, that interrupt operation, can be temporarily repaired by using a rigid mender. A rigid mender is a straight steel nipple that fits inside the two hose ends to be joined. Clamps secure the hoses to the nipple. Although rigid menders satisfactorily join the sections, they do introduce a rigid section in the hose which encumbers free travel of the hose on the cart path.

Permanent hose repairs require special equipment. Contact your Valley Dealer for permanent repair of hose or training and use of the special equipment.

## Rigid Mender Installation

1. Place the rigid mender between the two sections of hose. See figure 97-1.
2. Insert the mender halfway into the first hose section. See figure 97-1.
3. Slide the other hose section into the mender. See figure 97-1.
4. Secure both hoses onto rigid mender with band clamps. See figure 97-1.

## Flex Joint Hose Replacement

No extra support is needed when changing the flex joint hose. See figure 97-2.

1. Loosen the band clamps and slide out of way.
2. Remove the old flex joint hose.
3. Insert the new flex joint hose.
4. Position the band clamps and tighten completely.

### NOTE

•Position the band clamps so that they do not interfere with the alignment mechanism.

## Bonding Ground Wire

Bonding ground wire **MUST** be installed for proper ground between individual spans. See figure 97-2.

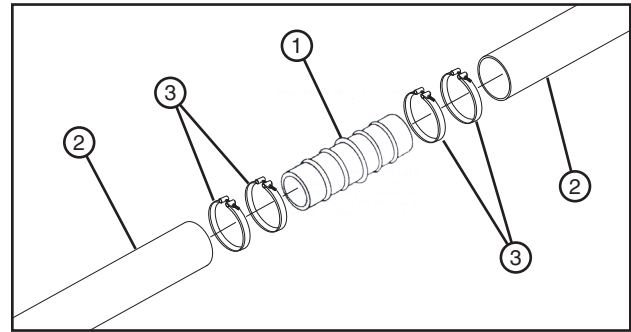

Figure 97-1 1. Rigid Mender  
2. Hose  
3. Clamp

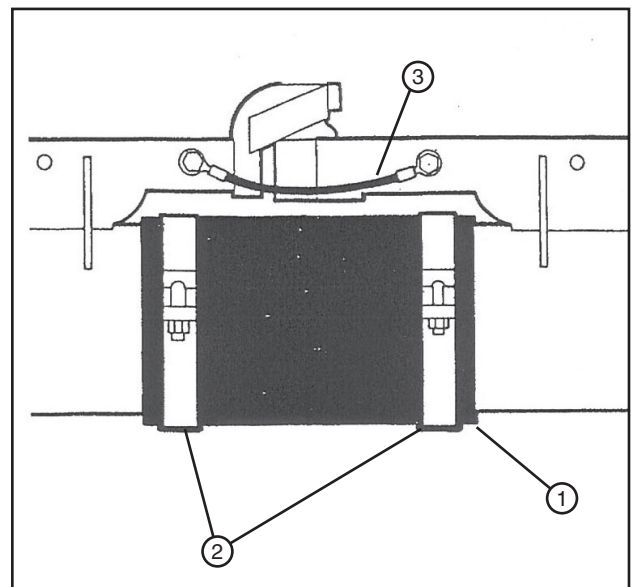

Figure 97-2 1. Flex joint hose  
2. Band clamp  
3. Bonding ground wire



# MAINTENANCE

## Machine Alignment

The machine is initially aligned when it is installed. However, for various reasons it may become necessary to adjust the alignment.

### **WARNING**

**DO NOT ALIGN THE MACHINE WHEN THERE ARE ESTABLISHED WHEEL TRACKS. WHEEL TRACKS MUST BE REMOVED BEFORE ALIGNING THE MACHINE TO REDUCE THE POSSIBILITY OF STRUCTURAL DAMAGE.**

Alignment should be checked annually and adjusted before there are wheel tracks.

Alignment is an important factor in the operation of the machine. A misaligned machine develops very high stresses which could cause structural damage and reduce expected motor and gearbox life.

A leading bow creates extreme tension or linear pulling force over the entire machine. See figure 98-1.

A trailing bow creates extreme compressing or linear pushing force on the entire machine. When the spans are compressed, they lose their inherent strength. See figure 98-1.

### **WARNING**

**A TRAILING BOW IN EITHER DIRECTION IS NEVER ACCEPTABLE AND MAY RESULT IN SEVERE STRUCTURAL DAMAGE.**

### **NOTE**

**If the irrigation machine is operated in forward and reverse, a leading bow in one direction becomes a trailing bow in the other direction. Therefore, such a machine should be aligned to operate in as straight a line as possible.**

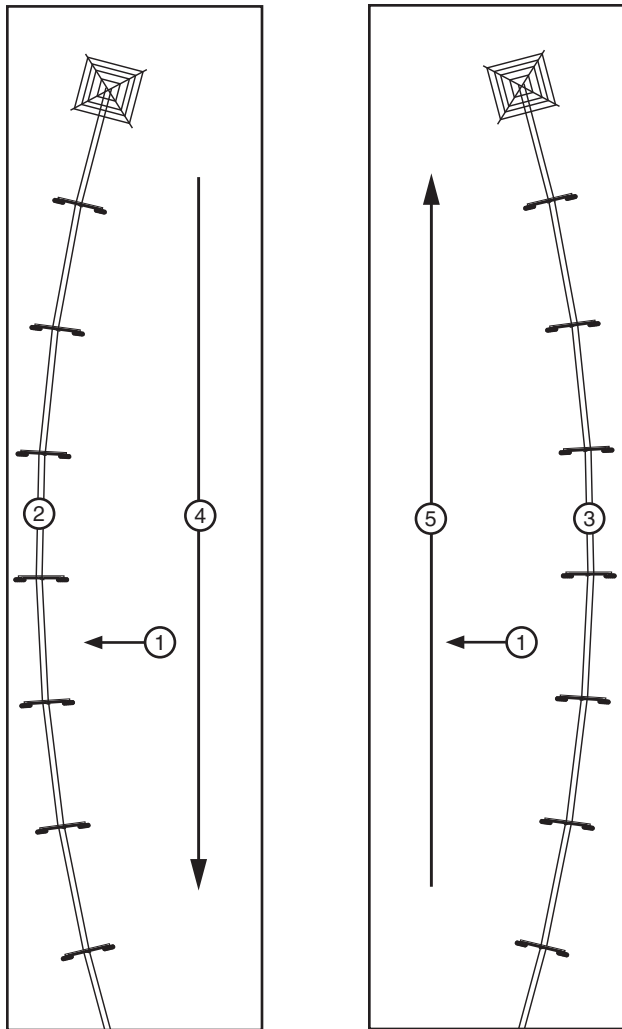

Figure 98-1 1. Direction of Travel  
2. Leading Bow  
3. Trailing Bow

4. Direction of Pulling  
5. Direction of Pushing

## Machine Alignment

### Tower Alignment - Three Tower Method

The three tower alignment method is used to identify towers that start or stop in a position that is either leading or trailing in relationship to the other two towers.

This procedure works best with two people:

- One person at tower 1 sighting the tower alignment.
  - One person at tower 2 adjusting the alignment.
1. At the control panel, set the percent timer at 50% and start the machine in either the forward or the reverse direction.
  2. Begin the alignment procedure from an end tower. Identify the first three towers as 1, 2, and 3. Use towers 1 and 3 to align tower 2. See figure 99-1.
  3. Sight an imaginary center line between the center of the tower drive motor 1 to the center of the tower drive motor 3. See figure 99-1.
  4. Observe the movement of the tower drive motor 2. It should start and stop equal distances from the imaginary center line. See figure 99-1.  
If it does not, the alignment linkage at tower box 2 needs to be adjusted.
  5. If adjustments are necessary, stop the machine and make adjustments using the Floating or Modified Alignment Adjustment procedures, located in the Adjustments Section of this manual.

### CAUTION

**ADJUSTMENTS TO THE CENTER TOWERS CAN CAUSE THE SYSTEM TO GO INTO A STEER. AFTER ADJUSTING THE ALIGNMENT WAIT FOR THE SYSTEM TO CYCLE TWICE BEFORE MOVING ON TO THE NEXT TOWER.**

6. After tower 2 is aligned, move in to the next tower and repeat steps 3, 4, and 5 of this procedure.  
Continue this process to the other end of the machine.

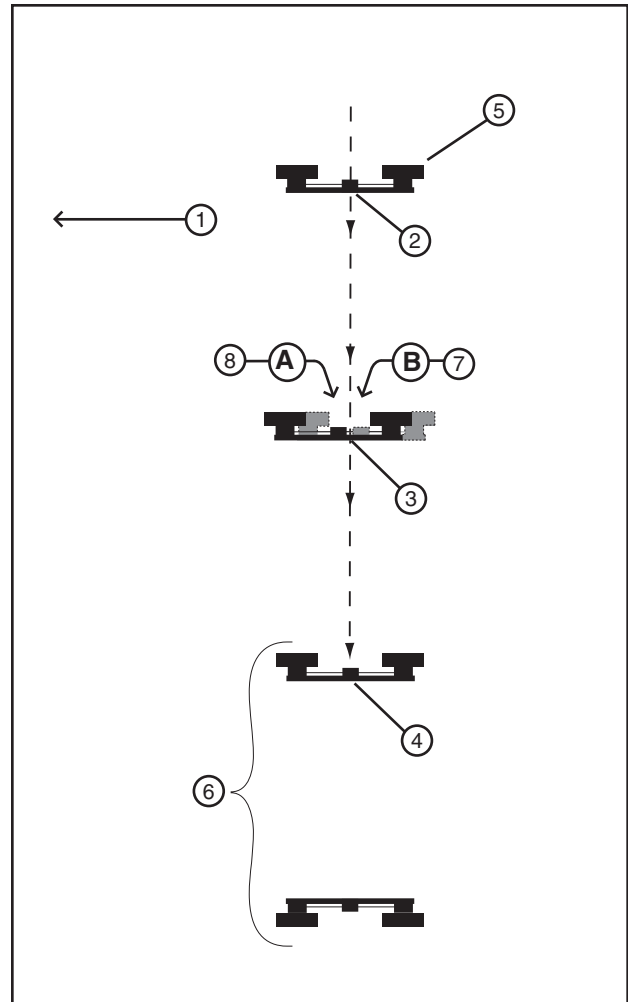

Figure 99-1 1. Direction of Travel 5. End Tower  
2. Tower 1 6. Free Standing Span  
3. Tower 2 7. Start  
4. Tower 3 8. Stop

# MAINTENANCE

## Machine Alignment Floating Alignment Adjustment

When a machine is equipped with floating alignment the tower box is located on the yoke and tower box support with a mechanical linkage between the tower box switch pivot arm and the yoke control rod. See figures 100-1 and 100-2.

### NOTE

All adjustments shown are made from the tower box side of drive unit.

1. Adjust nuts #1 and #2 as needed. Refer to figure 100-2 and 100-3.

### CAUTION

NEVER ADJUST NUTS #1 AND #2 MORE THAN 1/4 TURN AT ONE TIME.

• ALWAYS RE-TIGHTEN THE JAM NUTS AND ALLOW THE TOWER TO CYCLE TWICE (START AND STOP) TO DETERMINE IF THE TOWER IS STILL LEADING OR TRAILING.

2. Adjust nuts #1 and #2 until the tower is in alignment.
3. Continue the Three Tower Method of alignment down the entire length of the machine making adjustments as necessary to individual towers.



Figure 100-1

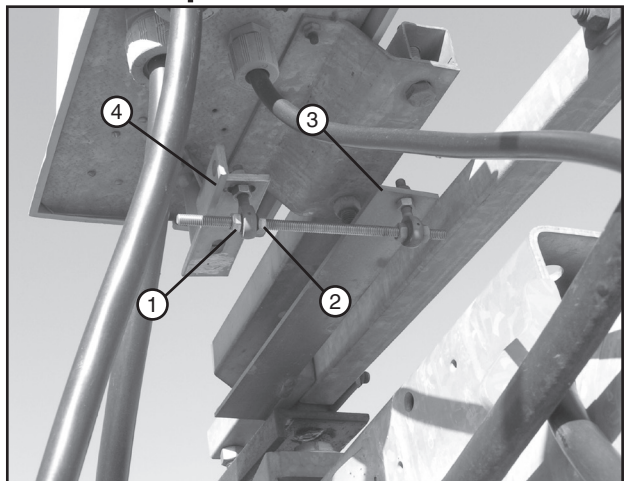

Figure 100-2 1. Nut 2. Nut 3. Yoke Control Rod 4. Switch Pivot Arm

### ADJUSTMENT CHART

Direction of travel	Condition	Adjust Nuts
Forward	Leading Bow	**Counter-clockwise
	Trailing Bow	*Clockwise
Reverse	Leading Bow	*Clockwise
	Trailing Bow	**Counter-clockwise

Figure 100-3 \* Clockwise - Adjust the nut further onto the threaded rod.

\*\* Counter-clockwise - Back the nut off the threaded rod as if removing it

## Machine Alignment

### Floating Alignment Cable Tension Adjustment

4. The alignment tube must be able to move up and down freely while adjusting cable tension.

If necessary loosen the cap screw until the alignment tube moves up and down freely. See figure 101-1.

5. Measure the distance from the end of the alignment tube down to the pipe. This is the pre-weight measurement. See figure 101-2.
6. Place a 13 lb (5.9 kg) weight on the alignment tube. Center the weight over the cable attachment assembly. See figure 101-3.

A standard 7/8 in (22.2 mm) square driveshaft 60 in (1524 mm) long weighs approximately 13lb (5.9kg).

7. Measure the distance from the end of the alignment tube to the span. This is the weighted measurement. See figure 101-3.

Subtract the weighted measurement from the pre-weight measurement. The remaining dimension is the amount of cable deflection. The cable deflection should be 1-1/4 in (32 mm).

8. Adjust the hook bolts evenly to obtain the proper cable deflection. See figure 101-3.

To insure equal tension in the cables, make sure the alignment tubes attached to the cables are aligned with the span.

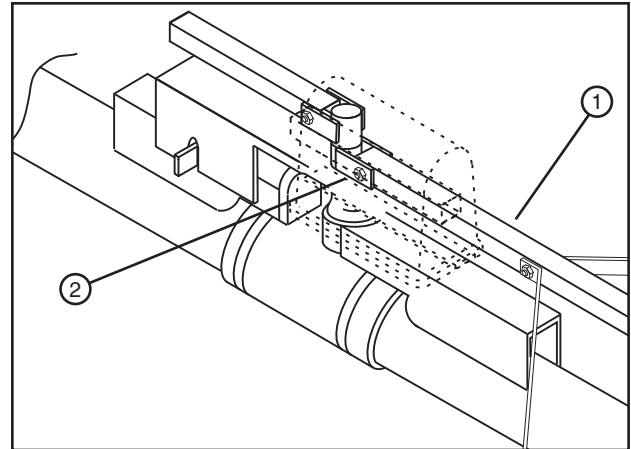

Figure 101-1 1. Alignment Tube  
2. Cap Screw

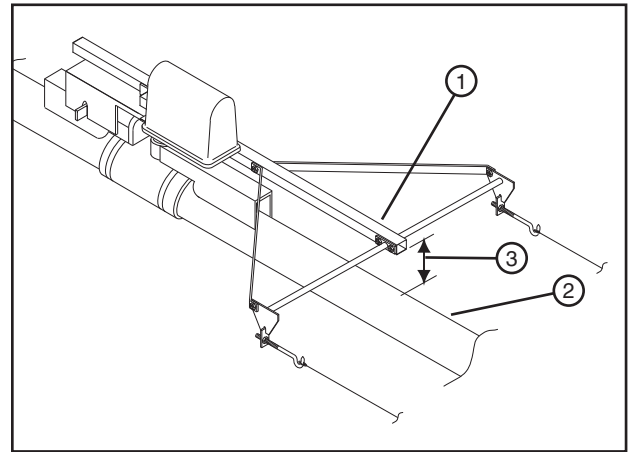

Figure 101-2 1. Alignment Tube  
2. Span  
3. Pre-weight Measurement

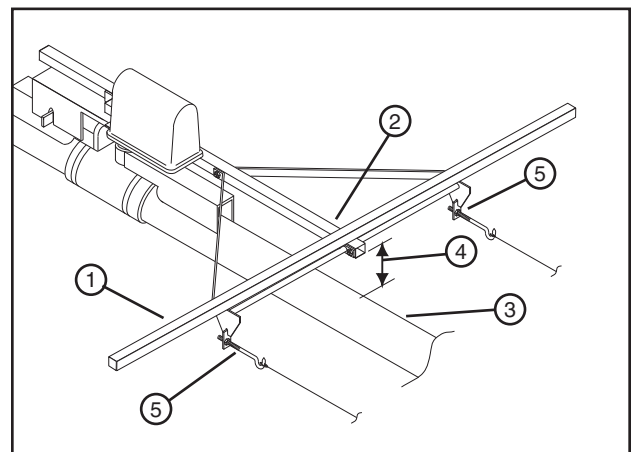

Figure 101-3 1. Weight 4. Weighted Measurement  
2. Alignment Tube 5. Hook Bolt  
3. Span

# MAINTENANCE

## Machine Alignment Modified Alignment Adjustment

When a machine is equipped with modified alignment the tower box is located on the side of the tower with a mechanical linkage between the tower box and the control bar.

### NOTE

All adjustments shown are made from the tower box side of drive unit.

9. From the tower box side of drive unit, loosen the jam nut at each end of the connection rod. See figures 102-1 and 102-2.
10. To adjust the distance between the control bar and the switch pivot arm, rotate the connection rod clockwise or counter-clockwise no more than 1/8 of a turn at one time. See figures 102-1 and 102-2, and the adjustment chart below.

### CAUTION

•NEVER ADJUST THE CONNECTION ROD MORE THAN 1/8 OF A TURN AT ONE TIME.

•ALWAYS RE-TIGHTEN THE JAM NUTS AND ALLOW THE TOWER TO CYCLE TWICE (START AND STOP) TO DETERMINE IF THE TOWER IS STILL LEADING OR TRAILING.

11. Adjust the connection rod until the tower is in alignment.
  - Sensitivity can be adjusted by repositioning the connection rod. See figure 102-3.
12. Continue the Three Tower Method of alignment down the entire length of the machine, make adjustments as necessary to individual towers.



Figure 102-1 1. Tower Box Side of Drive Unit

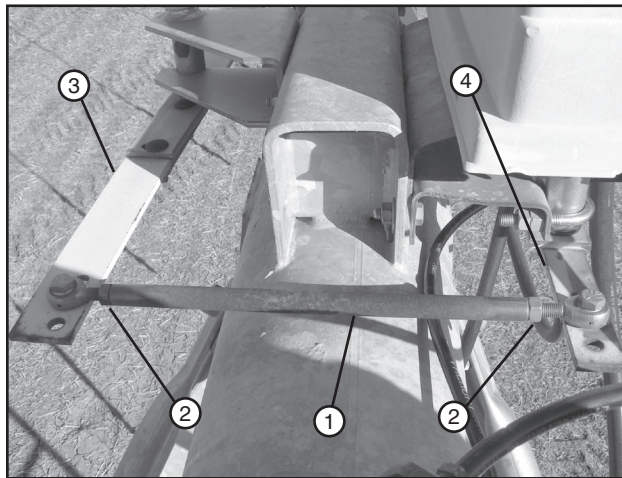

Figure 102-2 1. Connection rod 2. Jam nut 3. Control bar 4. Switch pivot arm

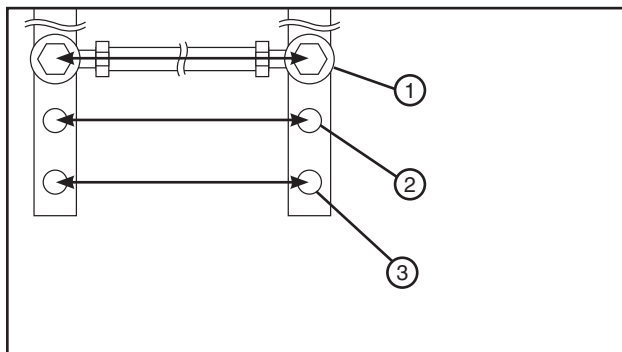

Figure 102-3 Connection Rod Sensitivity  
1. Position 1 - Least Sensitive  
2. Position 2 - More Sensitive  
3. Position 3 - Most Sensitive



## Span Flushing Procedure

The purpose of flushing the machine is to remove sand and debris from the pipeline. Excessive accumulation of sand in the machine also adds weight and can cause structural damage to the machine.

The Flushing Process Should Be Performed:

- After system installation.
- After pump repair.
- After structural repair.
- Seasonally - prior to operating the system and after the operating season is over.
- As often as necessary according to debris or sand content in the water. Excessive sprinkler problems (clogging) could be an indication of high debris or sand content.

## NOTE

- Excessive sprinkler problems (clogging) could be an indication of high debris or sand content.

## ⚠ DANGER

- DO NOT START THE FLUSHING PROCEDURE WHILE THE SYSTEM IS UNDER WATER PRESSURE. REMOVING SAND TRAP PLUGS WHILE THE SYSTEM IS UNDER PRESSURE MAY CAUSE PERSONAL INJURY OR DEATH.

1. Turn the pump is off and make sure machine is completely drained.

## ⚠ DANGER

- BE AWARE OF HIGH WATER PRESSURE. TURN OFF THE PUMP AND ALLOW THE MACHINE TO DRAIN COMPLETELY BEFORE REPAIRING OR PERFORMING MAINTENANCE TO THE MACHINE.

2. Turn the control panel main disconnect switch off. Only water is required for this procedure - the machine does not need to run.

Follow the MINIMAL LOCKOUT/TAGOUT PROCEDURE located in the SAFETY section of this manual and do the following:

- (a) SHUT OFF and LOCK the public power service disconnect to the irrigation machine. FILL OUT the blue (OSHA safety color code) tag and attach to the disconnect after locking. See figure 103-1.
- (b) SHUT OFF and LOCK the control panel main power disconnect. FILL OUT the blue (OSHA safety color code) tag and attach to the disconnect after locking. See figure 103-2.

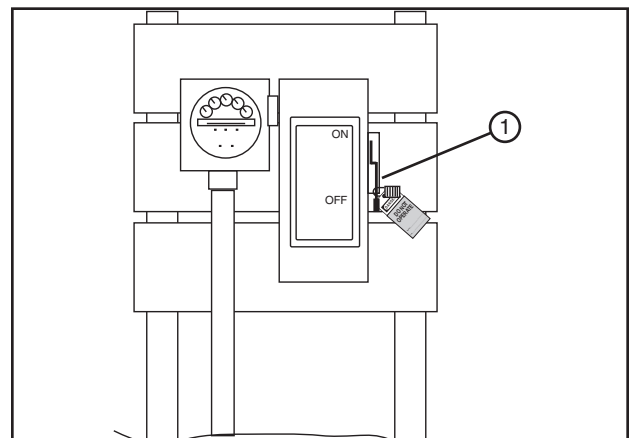

Figure 103-1 1. Public Power Service Disconnect



Figure 103-2 1. Main Disconnect  
2. Lock  
3. Blue OSHA Tag



# MAINTENANCE

## Span Flushing Procedure

3. Remove the pipe drains at each drive unit tower. Clean sand and foreign particles from these drains. Turn the rubber drain seal over when reinstalling. See figure 104-1.

### NOTE

•The rubber drain seals should be turned over when being reinstalled. This practice helps to increase the seal life.

4. Remove and clean the sand trap at the last regular drive unit. See figure 104-2.
5. Remove plugs from the overhang drains. Clean sand and foreign particles from these drains. Turn the rubber drain seal over when reinstalling. See figure 104-3.
6. Start the pump and allow the machine to flush thoroughly.
7. Turn off the water supply and re-install the pipe drains, sand trap and overhang plugs.

### NOTE

•After flushing for winterization, ensure the water has been allowed to drain completely before replacing the pipe drains and plugs to prevent freezing and splitting of the pipeline.

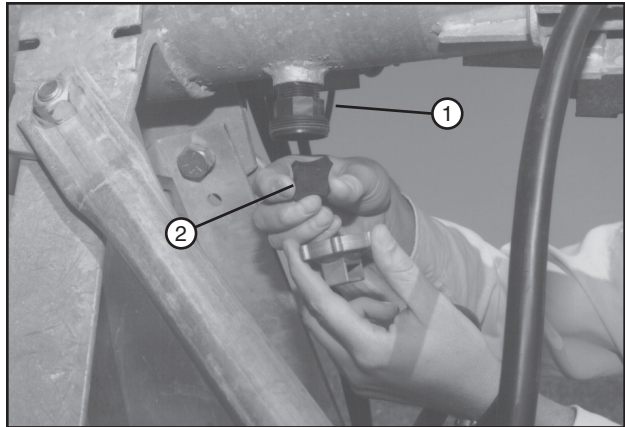

Figure 104-1 1. Pipe Drain  
2. Rubber Seal

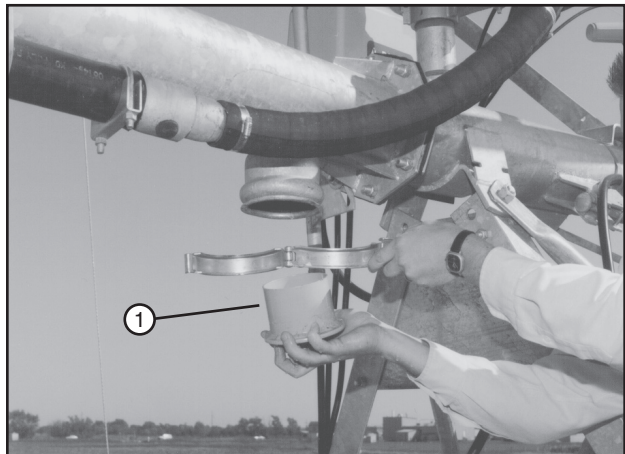

Figure 104-2 1. Sand Trap



Figure 104-3 1. Overhang Drain

## Span Flushing Procedure

8. If the machine is equipped with an end gun:

- Make sure the booster pump hose drain is not plugged with sand or debris and the hose is completely drained See figure 105-1.
- Clean the end gun shut off solenoid valve cross filter or optional dirty water filter. See figures 105-2 and 105-3.

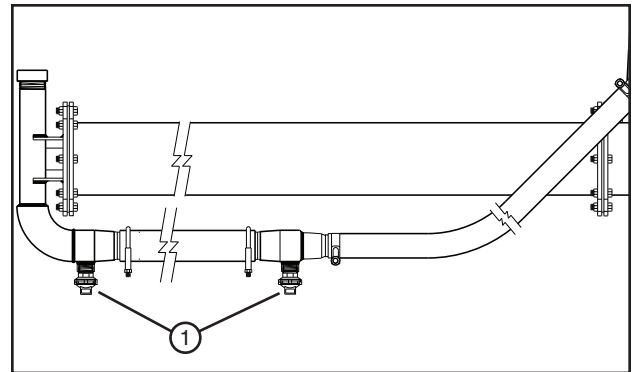

Figure 105-1 1. Booster Pump Hose Drain

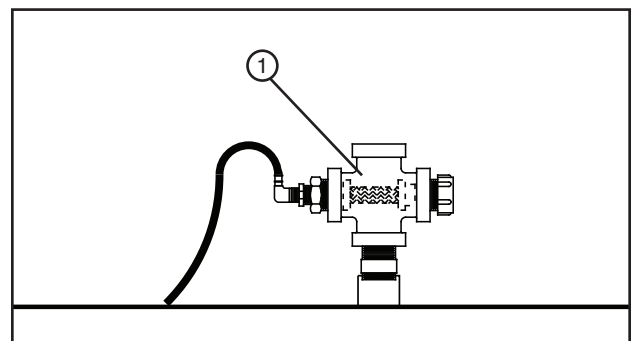

Figure 105-2 1. Cross Filter

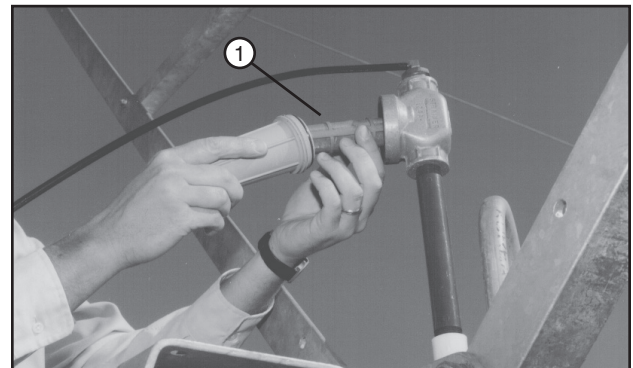

Figure 105-3 1. Optional Dirty Water Filter

# MAINTENANCE

---

## Winterization

In regions where the temperature during the winter months will drop below 40°F (4°C) and/or the growing season is 6 months or less, the irrigation machine **MUST** be winterized.

- Flush and drain the irrigation machine and all plumbing components as specified in the flushing procedure section. After flushing for winterization, ensure the water has been allowed to drain completely from all drains and plumbing components before replacing drains and plugs to prevent freezing and splitting of the pipeline.
- All underground pipe **MUST** be drained below the frost line. When drainage is complete, re-install all plugs to prevent rodent infestation.
- Perform all post-season maintenance as specified in the recommended maintenance section.
- Winterize auxiliary equipment such as pumps, power units, mainline pipes and hoses according to the auxiliary equipment manufacturers recommendations.

## Parking the Machine

The metal in the irrigation machine will expand and contract with variances in temperature. When the machine is being operated, this poses no threat. However, if the machine is parked in the wheel tracks which were created during the year, shrinking due to the contraction of the metal could cause structural damage.

The possibility of structural damage due to metal contraction increases as the machine length increases. Machines which are 1500 ft (457 M) or longer are susceptible to these stresses, especially where extreme temperature variances occur (90°F (32°C) down to -0°F (-17°C)) and when wheel tracks are present.

To reduce the possibility of structural damage due to expansion and contraction of the metal, the operator should consider one of the following methods when parking the machine in the off season:

1. Park the machine in an area where the wheel tracks have been eliminated.
2. Place wooden 2 in x 12 in planks over the wheel tracks. Park the machine with the tires on the center of the planks.
3. Towable Drive Units – Place every third drive unit's wheels in the tow position.
4. Remove all wheel tracks and run the machine dry (without water) for approximately 100 yards (92 m) to 200 yards (183 m) monthly. Only run the pivot if the temperature is above 40°F (4°C).
5. If an irrigation machine has more than 8 spans of 10 in (254 mm) pipe, the spans must be disconnected. Each span should be supported off the end of the previous span with chains to allow for contraction during cold weather.

Contact your Valley dealer for other winter storage/parking information and tips.

## Off Season Storage of Hose

**NEVER** leave the hose laying in the field during the winter. The hose can be easily covered by snow, mud, or dust and can quickly become damaged by farm equipment. Driving over the top of the hose can cause damage. Since some hoses contain PVC or rubber, extended exposure to sunlight can lead to cracking or checking problems.

After the final irrigation pass of the season, purge the hose of any remaining water.

Store the hose in a protected area where it will be sheltered from the weather and safe from livestock and rodents. Store the hose away from gas or diesel fuels, contaminants, transformers, and welding areas that can produce ozone.

## Off Season Storage of Electric Cord

Never leave the electric cord laying in the field during the winter. The electric cord can be easily covered by snow, mud, or dust and can quickly become damaged by farm equipment. Driving over the electric cord can cause damage.

After the final irrigation pass of the season, shut off power and disconnect electric cord plug from power receptacle. Install cap on plug and carefully coil and hang electric cord on machine.

# MAINTENANCE

## Recommended Maintenance

### Part Replacement

If replacement parts are needed, use only genuine VALLEY REAL PARTS.

### Regular Maintenance

Time, humidity, vibration, temperature, sand, and machine operation all contribute to wear on your VALLEY irrigation machine. To keep the machine operating properly with a minimum amount of down time, establish a regular preventative maintenance program using the recommended maintenance charts in this section.

<b>Linear Machine</b>						
	Pre season	1st Pass	4th Pass	Mid season	Post season	Remarks
Check all nuts and bolts. Tighten as required.	X			X		
Check anchor bolts and chains.	X			X		
Check equipment grounding conductors. Tighten or clean as required.	X			X		
Check condition of all power supply conduit and wires.	X			X		Replace or repair any broken conduit or wire with cracked insulation.
If applicable, check collector ring base drain for proper drainage.	X			X		
Visually check pivot contacts for evidence of arcing.	X				X	Burned or pitted contact points indicate low voltage. If using a generator, check belts for proper tension.
Drain riser assembly.					X	
Check placement of screens on generator, pump panel, and electric motors (used to prevent rodent damage).	X				X	
Check tire pressure.	X			X	X	See the TIRE PRESSURES in the MAINTENANCE SECTION.
Check condition of electrical conductor.	X				X	Replace if frayed, worn or weather checked.

<b>Span</b>						
	Pre season	1st Pass	4th Pass	Mid season	Post season	Remarks
Check all nuts and bolts. Tighten as required.	X			X		
Check flanges for leaks and tighten as required.	X			X		
Check pipe drains for proper drainage. Clean as required.	X			X		
Check structural components for tightness.	X			X		
Check span cable for damage.	X			X		Replace or repair cable if chaffed or weather checked.
Check span cable for proper banding.	X			X		Replace bands and adjust span cable as required.

# MAINTENANCE

## Recommended Maintenance

Sprinkler						
	Pre season	1st Pass	4th Pass	Mid season	Post season	Remarks
Check the water pressure to make sure it matches the sprinkler package pressure.	X		X	X		
Check sprinklers and nozzles for tightness.	X			X		
Check spray nozzles for pumping air or the pump is hard to prime.	X			X		Check for vacuum leaks at the suction inlet.
Check sprinkler for free movement.	X			X		
Check sprinkler nozzles for wear.	X		X	X		
Check pressure gauge or pressure transducer for proper operation.	X			X		
Check for plugged or partially plugged nozzles.	X	X	X	X		Clean as required.
Flush entire machine.	X				X	See the FLUSHING PROCEDURE in the MAINTENANCE SECTION.
Check end gun bearing and brake setting.	X				X	

Alignment						
	Pre season	1st Pass	4th Pass	Mid season	Post season	Remarks
Check all nuts and bolts.	X			X		Tighten as required.
Check connection of grounding bond jumpers.	X			X		
Check all safety switches for proper operation.						As required.
Check surge suppressor connection.	X					
Visually check alignment of machine.	X			X	X	DO NOT adjust if wheel tracks have been established.
Check the cable tension - floating alignment.	X					
Check the alignment tube for vertical motion.	X					
Check the alignment tube for horizontal motion on the stainless steel shaft	X					
Check the cross bar tube for motion on the stainless steel shaft	X					
Check the ball joints for freedom of movement.	X					
Check for cap over modified alignment control rod cotter key and washer.	X					Replace cap if missing.

# MAINTENANCE

## Recommended Maintenance

<b>Overhang, End Gun And Booster Pump</b>						
	Pre season	1st Pass	4th Pass	Mid season	Post season	Remarks
Check overhang cables for broken cable strands.	X			X		
Check the end gun drain.	X			X	X	Clean as required.
Check the sand trap.				X	X	Clean as required.
Check the end gun arc settings.	X			X		Refer to sprinkler chart.
Check the end gun bearing and brake.	X			X		
Check the end gun nozzle for wear.	X					
Drain the booster pump and booster pump hose.					X	See WINTERIZATION in MAINTENANCE SECTION.



<b>Drive Unit</b>						
	Pre season	1st Pass	4th Pass	Mid season	Post season	Remarks
Check the water and flex joint hose for leaks.	X			X		Tighten clamps or replace as required.
Check the motor lead cable for damage.	X			X		Replace if outer insulating sheath is cracked.
Check for proper ground connection on motor and motor lead.	X			X		
Check the motor drain hole for proper drainage.	X			X		
Check the center drive gearbox lubricant and drain moisture.	X				X	See the CENTER DRIVE GEARBOX in the MAINTENANCE SECTION.
Change the center drive gear box lubricant.	X					Change after the first season and then change every third season thereafter.
Check the center drive gearbox seals and gaskets.	X					
Check the wheel gearbox lubricant level and drain moisture.	X				X	See the WHEEL GEARBOXES in the MAINTENANCE SECTION.
Change the wheel gearbox lubricant.	X					Change after the first season and then change every third season thereafter.
Check the drive shaft U-joints.	X					
Check the U-joint and drive shaft covers for damage.	X					Replace as required
Check the wheel lug nut torque.	X				X	Tighten to 125 lb-ft (169 N-m) torque.
Check the tire pressure.	X			X	X	See the TIRE PRESSURES in the MAINTENANCE SECTION.
Clean the wheel gearbox vent hole in expansion chamber.	X		X	X	X	Vent hole must be kept open to extend the wheel gearbox seal life.
Check the ARAS/EOFS arms for proper operation.	X			X		



# MAINTENANCE

## Recommended Maintenance

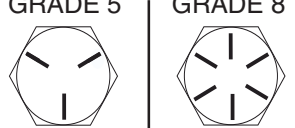
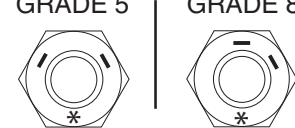
Ancillary Equipment						
	Pre season	1st Pass	4th Pass	Mid season	Post season	Remarks
Perform all maintenance as required or recommended by the ancillary equipment manufacturer.	X	X	X	X	X	Refer to the ancillary equipment owner's manual or manufacturer for required or recommended maintenance and service intervals

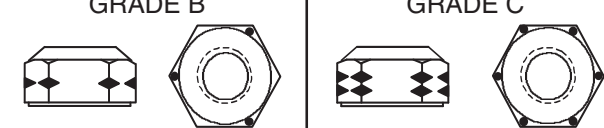
Hardware Identification - SAE Grade - Inch Size					
<p>CAP SCREW</p> <p>GRADE 5   GRADE 8</p> 		<p>NUT</p> <p>GRADE 5   GRADE 8</p>  <p>* Vendor's Mark</p> 		<p>LOCKNUT</p> <p>GRADE B   GRADE C</p>  <p>Use With Grade 5 Screw   Use With Grade 8 Screw</p>	

Torque Chart - Hex Head Cap Screws								
SIZE INCH	GRADE 5				GRADE 8			
		ACCEPTABLE RANGE		ACCEPTABLE RANGE		ACCEPTABLE RANGE		ACCEPTABLE RANGE
	lb-ft	lb-ft	N·m	N·m	lb-ft	lb-ft	N·m	N·m
1/4	9	8-9	12	11-12	12	11-13	16	15-17
5/16	18	16-19	24	22-25	25	22-27	34	30-36
3/8	31	28-33	42	38-44	43	39-47	58	53-64
7/16	49	44-53	66	60-71	69	63-75	94	85-101
1/2	75	68-81	102	92-109	106	96-115	144	130-156
9/16	108	98-117	146	133-158	152	139-166	206	188-225
5/8	149	135-162	202	183-219	210	191-229	285	259-310
3/4	264	240-297	358	325-402	372	338-406	504	458-550
7/8	426	387-464	577	525-629	601	546-655	815	740-888
1	637	579-695	863	785-942	900	818-982	1220	1109-1331

Special Torque Applications				
SPANS & DRIVE UNITS	GRADE 5		GRADE 8	
	lb-ft	N·m	lb-ft	N·m
Hitch ball bolts*	750	1016.8	1050	1423.6
Wheel lug nuts	125	169.4		
Gear Box mounting bolts	75	101.6		

**\*DO NOT reuse this hardware after removal. Always replace hardware that has been removed with new hardware of the correct grade and size.**



# TROUBLESHOOTING

## Safety

### DANGER

- THE CONTROL PANEL CONTAINS HIGH VOLTAGE! 480 VOLTS CAN KILL.
- ALWAYS DISCONNECT ELECTRICAL POWER BEFORE SERVICING OR PERFORMING MAINTENANCE TO THE MACHINE.
- TESTING AND TROUBLESHOOTING SHOULD BE PERFORMED ONLY BY AN AUTHORIZED VALLEY DEALER.
- ALWAYS REPLACE ANY GUARDS OR SHIELDS THAT ARE REMOVED FOR PERFORMING MAINTENANCE.

### Disconnect All Power

Before performing service or maintenance on any part of the machine, follow the MINIMAL LOCKOUT/TAGOUT PROCEDURE located in the SAFETY section of this manual and do the following:

1. SHUT OFF and LOCK the public power service disconnect to the irrigation machine. See figure 112-1.  
FILL OUT the blue (OSHA safety color code) tag and attach to the disconnect after locking. See figure 112-1.
2. SHUT OFF and lock the control panel main power disconnect. See figure 112-2.  
FILL OUT the blue (OSHA safety color code) tag and attach to the disconnect after locking. See figure 112-2.

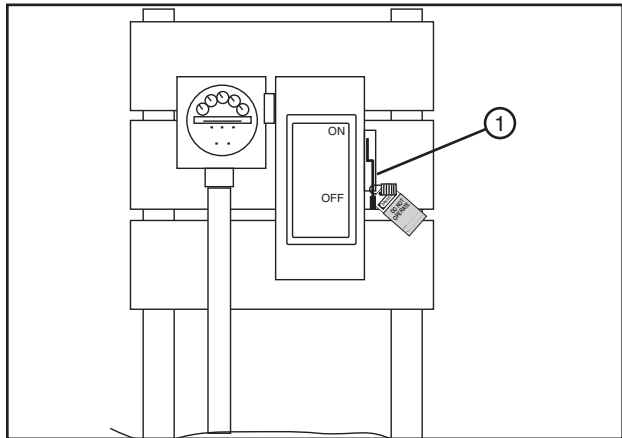

Figure 112-1 1. Public Power Service Disconnect

### DANGER

- BE AWARE OF HIGH WATER PRESSURE. TURN OFF THE PUMP AND ALLOW THE MACHINE TO DRAIN COMPLETELY BEFORE REPAIRING OR PERFORMING MAINTENANCE TO THE MACHINE.

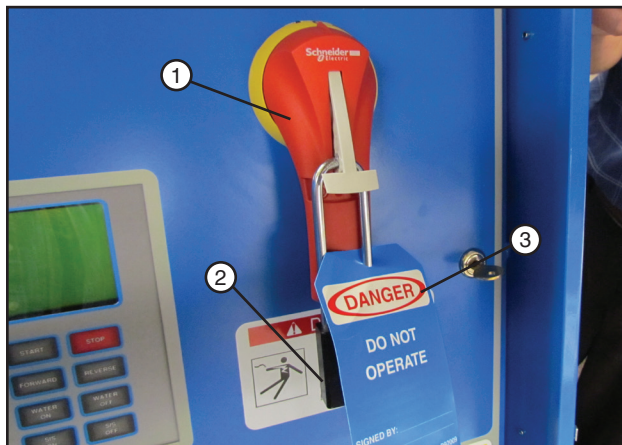
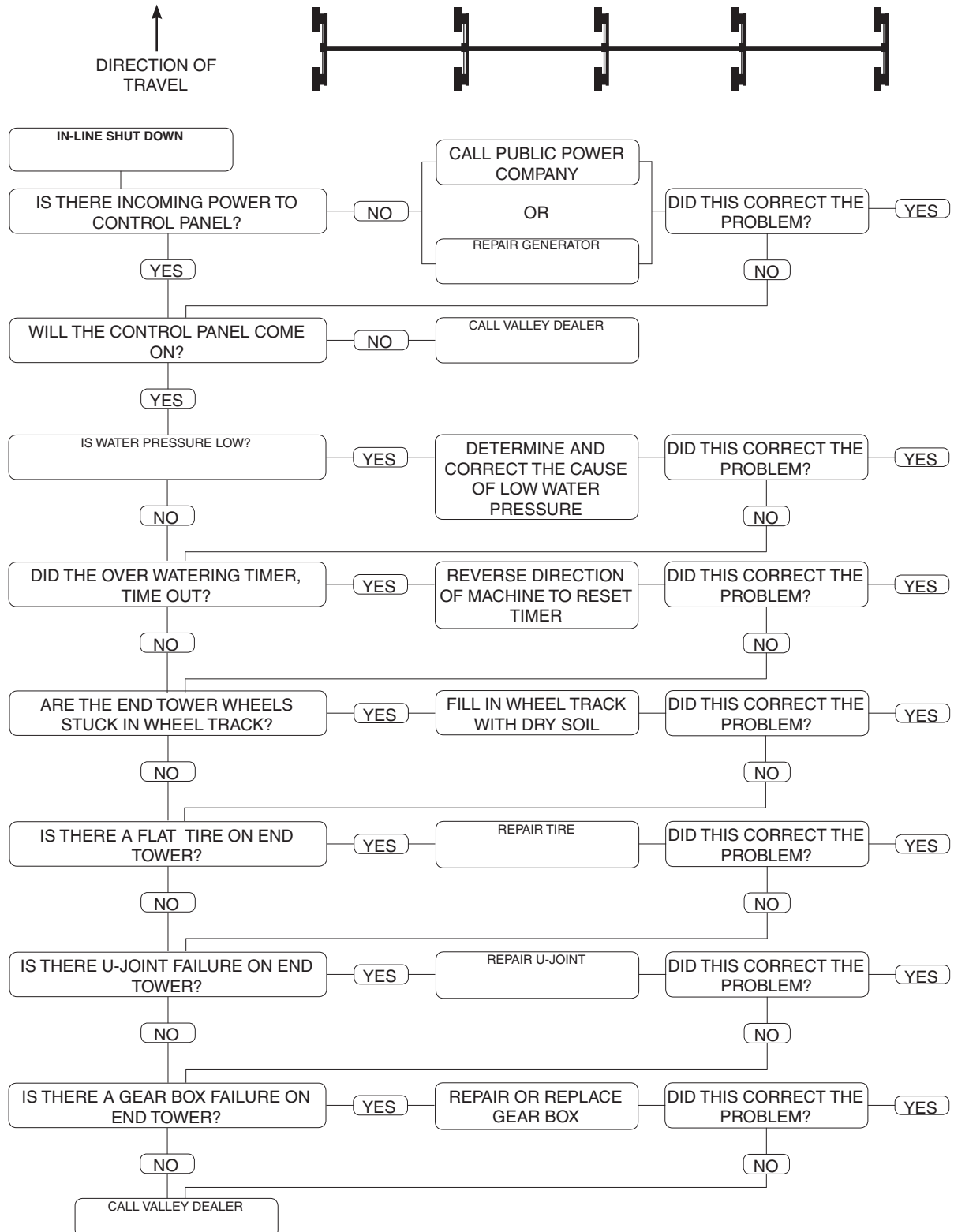

Figure 112-2 1. Main Disconnect  
2. Lock  
3. Blue Tag

# TROUBLESHOOTING

## In-Line Shut Down

In-line shut downs typically occur because of a failure in one or more of the following areas: power source, machine controls, or end tower. Use the flow chart below to determine if the in-line shut down was due to a mechanical failure. Refer to the control panel Owners Manual for other TROUBLESHOOTING information.



# TROUBLESHOOTING

## Tower Ahead Shut Down

In a tower ahead shut down, the tower which is out of line and the farthest ahead fails to shut off and breaks the safety circuit.



### WARNING

- TO REDUCE THE POSSIBILITY OF STRUCTURAL DAMAGE, NEVER REVERSE THE DIRECTION OF TRAVEL AFTER A TOWER AHEAD SHUT DOWN. AFTER MACHINE IS REPAIRED, ALWAYS OPERATE IN THE SAME DIRECTION OF TRAVEL AS BEFORE THE SHUT DOWN. WHEN THE MACHINE COMES BACK INTO ALIGNMENT THE DIRECTION CAN BE CHANGED.

Tower ahead shut downs typically occur because of a component failure in the tower box. Some causes of tower ahead shut downs are shown below. Call your Valley Dealer to diagnose and repair a tower ahead shut down. Refer to the control panel Owners Manual for other TROUBLESHOOTING information.

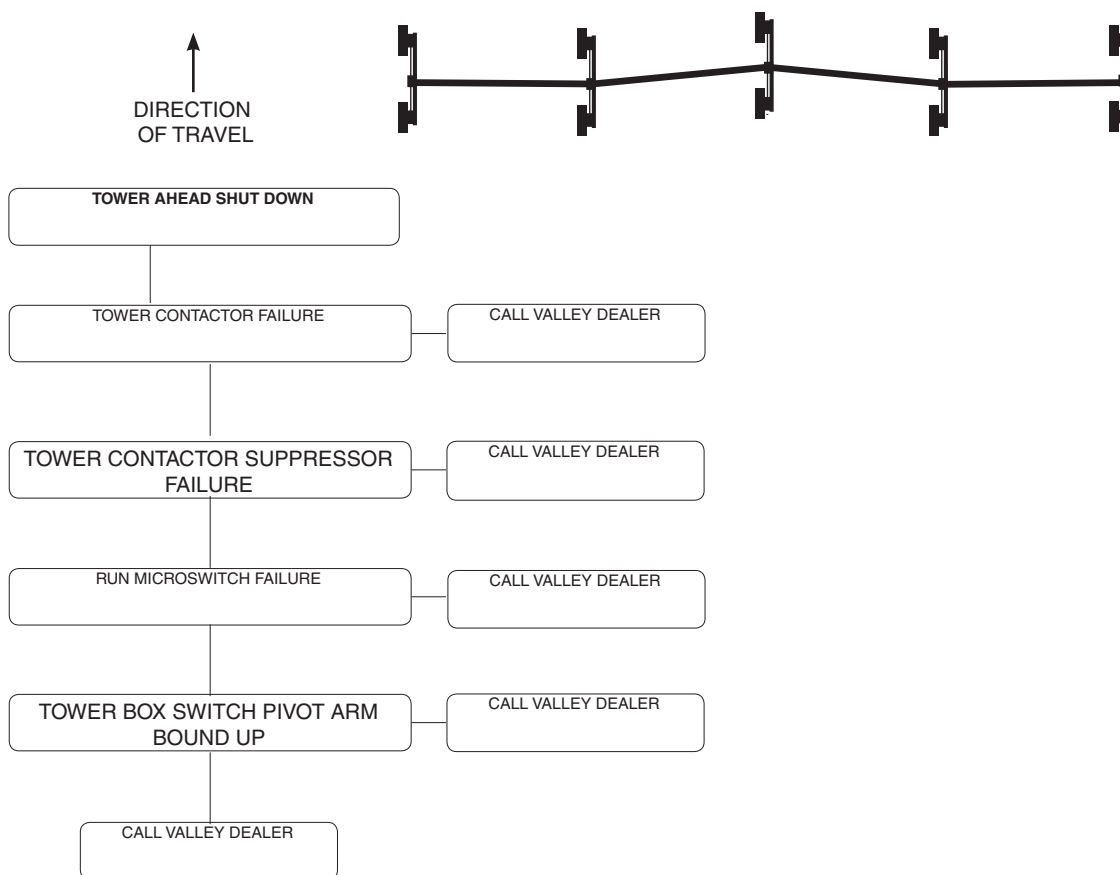

# TROUBLESHOOTING

## Tower Behind Shut Down

In a tower behind shut down, the tower which is out of line and the farthest behind, fails to run and breaks the safety circuit.

### WARNING

•TO REDUCE THE POSSIBILITY OF STRUCTURAL DAMAGE, NEVER OPERATE THE MACHINE IN THE SAME DIRECTION OF TRAVEL AS THE MACHINE WAS OPERATING WHEN THE SHUT DOWN OCCURRED. AFTER MACHINE IS REPAIRED, ALWAYS OPERATE IN THE OPPOSITE DIRECTION OF TRAVEL AS THE MACHINE WAS OPERATING BEFORE THE SHUT DOWN. WHEN THE MACHINE COMES BACK INTO ALIGNMENT THE DIRECTION CAN BE CHANGED.

Tower behind shut downs typically occur because of a failure in one or more of the following areas; tower box, drive train or machine alignment. Use the flow chart below to determine if the cause of shut down is mechanical. Refer to the control panel Owners Manual for other TROUBLESHOOTING information.

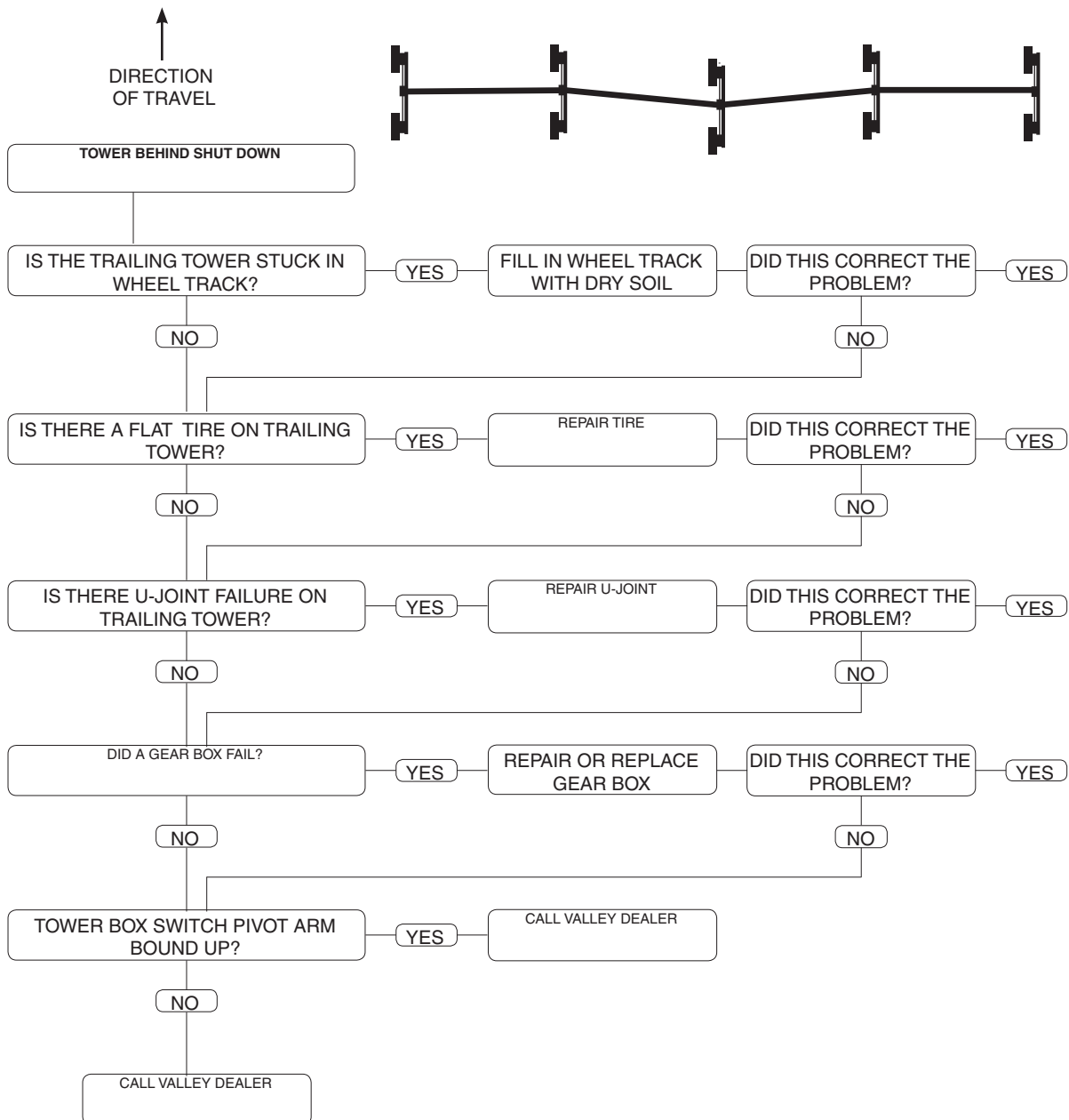



# TROUBLESHOOTING

## Operation

PROBLEM	POSSIBLE CAUSE	SOLUTION
System will not hold the safety.	Drive unit out of alignment, breaking the Span Safety Box switch.	Move drive unit back into alignment and determine cause.
	Flat or low tire causing misalignment of drive units.	Repair or replace
	Gearbox motor failure.	Contact your local Valley dealer.
	Electrical component failure.	Contact your local Valley dealer.
	Center drive gearbox failure.	Repair or replace
	Wheel gearbox failure.	Repair or replace
	Drive shaft/U-joint failure.	Repair or replace
	Guidance control box microswitch failure.	Contact your local Valley dealer.
	Pulse tower box microswitch failure.	Contact your local Valley dealer.
	Span safety box microswitch failure.	Contact your local Valley dealer.
	Machine not positioned correctly with guidance system.	Align the machine, then attempt to restart in the opposite direction of travel to align the machine with guidance system.
Oscillator power supply failure.	Contact your local Valley dealer.	
System holds safety, but the end tower will not move in the run mode.	Low pressure switch defective.	Contact your local Valley dealer.
	Bad relay on relay board.	Contact your local Valley dealer.
Machine shut down in-line.	Engine/generator stopped.	Check fuel supply.
		Check fuel filter.
		Check water separator.
		Check oil level.
		If no problems are discovered, turn the control panel disconnect to the off position and attempt to restart the engine/generator.
	Incoming power failure.	Call the power company.
	Plug pulled out of receptacle.	Make sure the cord is long enough.
Make sure the end of cord stop is set correctly.		
Loss of water pressure.	Check pump for proper operation.	
Low voltage or intermittent low voltage.	Engine RPM too slow.	Adjust the engine/generator as needed. Refer to the engine/generator owner/operator's manual.
	Intermittent excessive load..	Attempt restart of machine. If the machine restarts, monitor the voltage and continue operation.

# TROUBLESHOOTING

## Operation

PROBLEM	POSSIBLE CAUSE	SOLUTION
Machine will not run after pressing the start button.	Auto stop switch is depressed.	Attempt restart of machine in the opposite direction of travel.
	End of field stop switch is depressed.	Attempt restart of machine in the opposite direction of travel.
	End of hose stop switch is depressed.	Remove hose stop post and attempt restart of machine in the same direction of travel.
	Safety microswitch stuck in the open position.	Contact your local Valley dealer.
Engine will not rev up to the rated engine RPM.	Clogged fuel filters.	Replace.
	Air entering engine fuel supply line.	Contact your local Valley dealer.
	Injector nozzles plugged.	Clean injector nozzles.
	Injector pump malfunction.	Repair or replace
	Clogged air intake filter.	Replace.
Radical steering in both directions.	Pulse timer failure.	Contact your local Valley dealer.
Excessive steering in both directions.	Intermittent failure of wiring between the control panel and the steering boxes.	Contact your local Valley dealer.
Immediate steer, out of position when the machine is calling for a minor steer, into position with guidance system.	Incorrect wiring at the control panel or steering box.	Contact your local Valley dealer.
Steering properly in one direction of travel, but the machine wanders in the other direction of travel.	Failure of steering relay.	Contact your local Valley dealer.
	Above ground cable or furrow guidance box out of adjustment.	Adjust above ground cable or furrow guidance box.
	Furrow guidance furrow not straight.	Repair furrow.
	Above ground cable guidance cable tension too slack.	Adjust above ground cable tension.
	Wheel track on cart path causing cart to lean.	Repair wheel track.
	Steering arms do not return to the neutral position.	Check the steering arms and linkage for binding.
	Cam or micro switch out of adjustment.	Contact your local Valley dealer.

# TROUBLESHOOTING

## Operation

PROBLEM	POSSIBLE CAUSE	SOLUTION
Hose is snaking (a certain amount is acceptable).	Hose under excessive pressure.	Do not exceed recommended 150 psi (1034 kPa) water pressure.
	Improper hose layout.	Lay hose out in straight line at the edge of the runway with the recommended bend diameter. Pull hose taut, removing all slack before pressurizing.
Hose cover blisters.	Kinking - insufficient bend radius.	Increase the bend radius when laying the hose out.
	Poor cover adhesion.	Cut out the affected area and apply a cover repair.
	Hose has a pin hole leak.	Remove the blistered area and splice the hose. Install a pin hole plug.
Cover gouges, cuts, scrapes, abrasions.	Foreign obstruction in the runway.	Keep runway clear.
	Sharp object on the machine.	Check the machine for a sharp object and remove.
	Running over the hose with the cart or other equipment.	Protect the hose and do not run over hose or walk on it.
Hose cover repair being peeled or stripped off.	Foreign objects in runway.	Keep runway clear. Repair cover with cover repair kit.
	Improperly applied cover repairs.	Reapply cover repair following the manufacturer's instructions carefully.
Hose pulls in two.	Hose cut by debris in the runway.	Make sure runways are clear of debris and are level and grassy.
	Hose caked heavily with mud or clay.	Clean hose after each pull.
	Hose stretched to maximum length when water pressure is turned off.	Leave some slack in the hose to allow for 2-3% elongation [13-20 ft (3.96 M - 6.07 M) in a 660 ft (201 M) length].
	Hose used as a tow rope.	Never use the hose as a tow rope to pull equipment.
	Hose stop post is not installed.	Install the hose stop post.
Couplings pull off.	Coupling improperly installed.	Cut hose and reapply coupling.
	Excessive mud on hose.	Clean mud off of hose and reapply coupling.

# TROUBLESHOOTING

## Operation

PROBLEM	POSSIBLE CAUSE	SOLUTION
Longitudinal scratches or cuts on the hose.	Sharp project in runway.	Keep the lanes clean.
		Check the equipment for sharp edges or protrusions.
Vertical breaks in the hose.	Improper bend at loop, causing the hose to kink.	Maintain recommended bend diameter.
	Insufficient water pressure.	Increase the pressure at the pump to a minimum of 70 psi (483kPa).
Water blisters forming behind the coupling.	Improperly applied coupling.	Take care to apply correctly according to the manufacturer's instructions.
	Tube cut while coupling is being installed.	Take care to apply correctly according to the manufacturer's instructions.
Hose cover checking cracking at the edges.	Stored incorrectly near electrical equipment.	Store 150 ft (46 M) from electrical motors.
	Stored for extended period of time in direct sunlight.	Store hose in cool, dry protected areas.