

END TYPE			
DETAIL No.	DETAIL	DETAIL No.	DETAIL
1	<p>STANCHION DRILLED THROUGH</p>	2	<p>STANCHION DRILLED THROUGH</p>
3	<p>STANCHION DRILLED THROUGH</p>	4	<p>DOSO STANCHION</p>
5	<p>STANCHION DRILLED THROUGH</p>	6	<p>DOSO STANCHION</p>

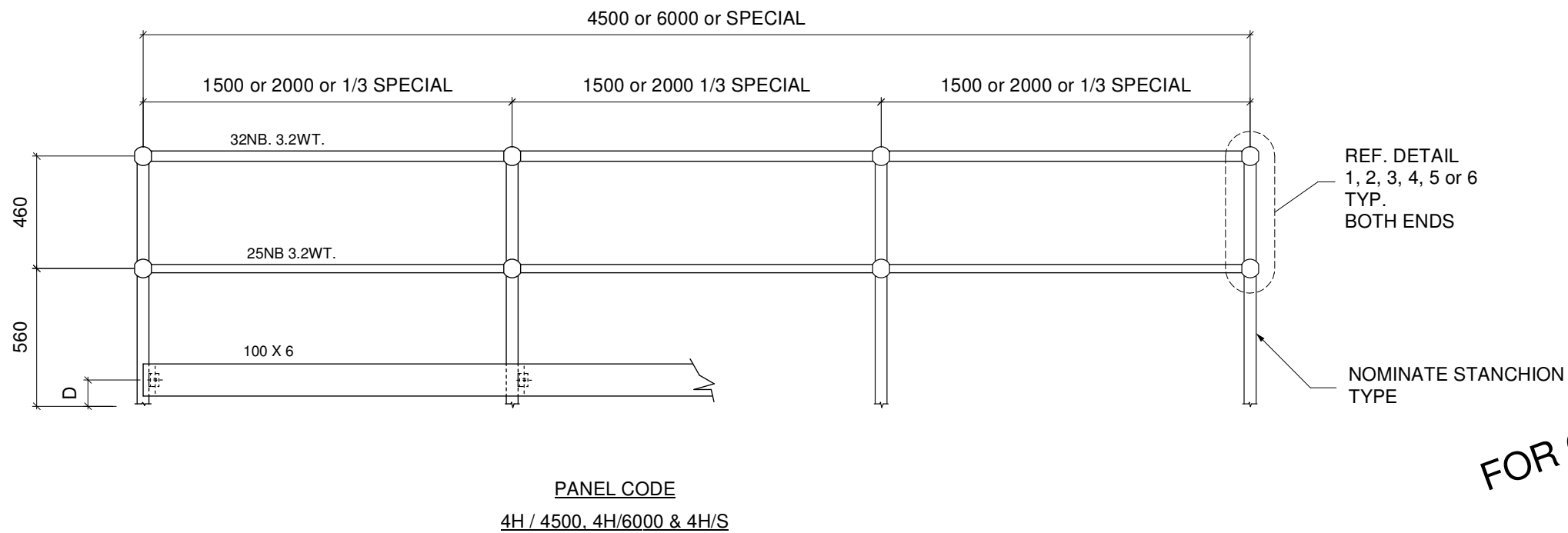
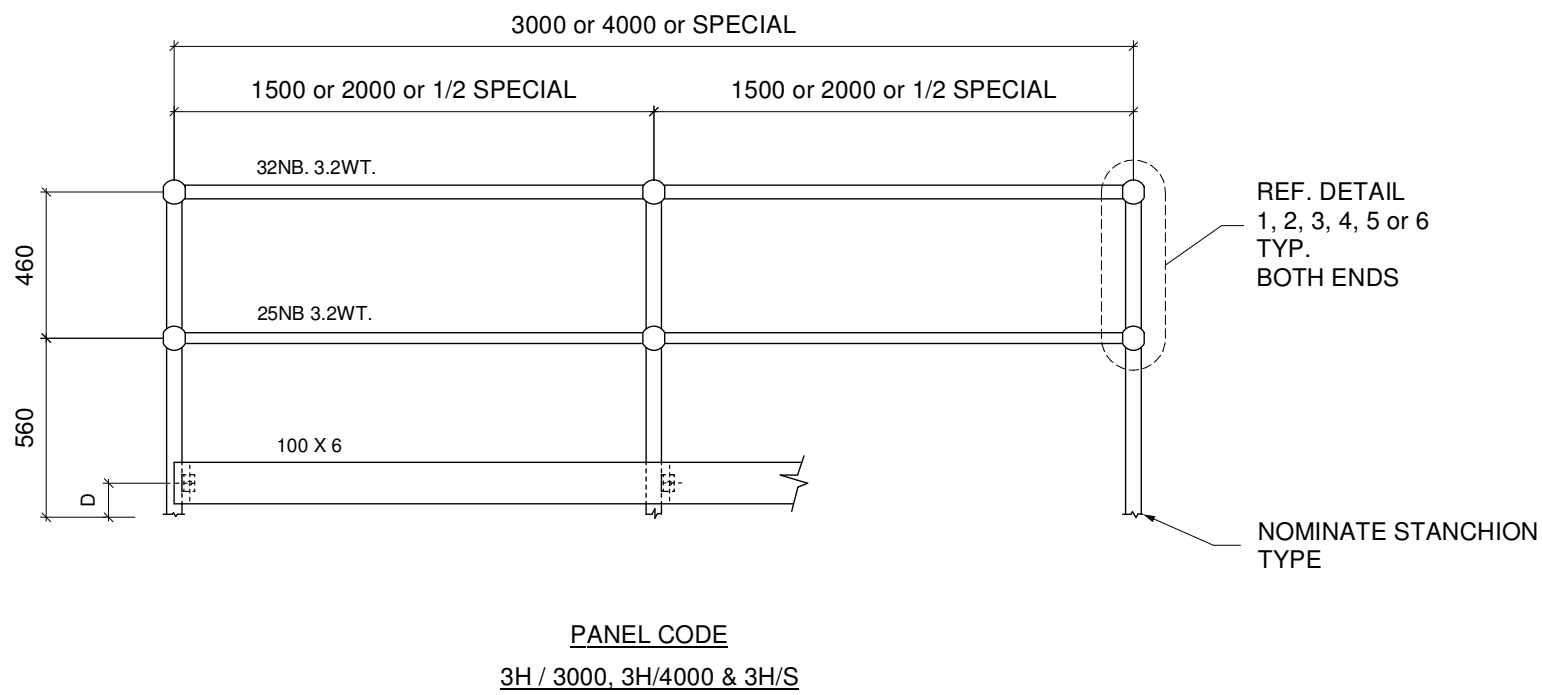

FOR GENERAL RELEASE

REV	PARTICULARS	BY	DATE
1	Kpl brkts corrected	JN	19/03/14
0	RE-NUMBERED FROM STD-033r4	TW	23/5/05

CLIENT: STANDARD HANDRAIL PANELS - HORIZONTAL

DETAIL: STD-130/0

WEBFORGE GRID TYPE	SURFACE TREATMENT	REQ'N No.	STD-130/0
DRAWN TAW	CHK	CUST. ON.	DRAWING No. STD-130
DATE 4/6/02	JOB No.	REV.	1

WEBFORGE (WA)
24 TENNANT STREET, WELLSPOOL
WESTERN AUSTRALIA
A.C.N. 009 419 756
Phone (08) 9361 8933 Fax (08) 9361 7057