

Access Products Division



WEBFORGE

Webforge Contents

The Company

Services:

- In excess of 50 years experience
- Branches throughout Australia, Asia and New Zealand
- Manufacture
- Design
- Technical Support
- Quotations
- Fabrication
- Quality Assurance
- Feasibility and Budget Rates
- Lump Sum and Rate Contracts
- Project Management
- Small Jobs
- Large Projects
- Computerised Job Tracking

Products:

- Bar Grating
- Handrailing
- Expanded Metal
- Balustrades
- Drainage Grates and Cast Covers
- Sunscreens

FLOORING

Quick Guide.....	1
Choose a Pattern.....	2
Options	3
Coding	4
Load/Deflection Tables	6
FRP	8
Expanded Metal	12
Stair Treads	14
Fixing Clips	16
Manufacturing Tolerances	18
Webplate/Webmesh	20
Terminology	21

HANDRAILS

Choose a Stanchion	22
Brackets/Baseplates/Offsets	24
Bends/Closures/Gates	25
Options/Ordering	26
Specifications	27
Barrier Products	28
Balustrades	29
Jumbo Stanchions	30

CONTENTS

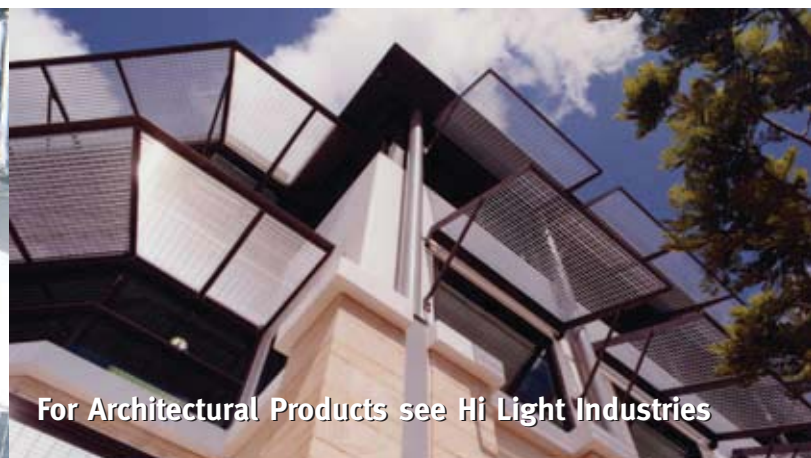

For Architectural Products see Hi Light Industries



For Civil Products see separate brochure

Barrier Products

Fabrication

All the items shown on the preceding pages can be supplied loose or fabricated into panels ready for installation on site.

- Untreated.
- Hot Dip Galvanised after fabrication.

- Ball to rail welding : for AS1657 20mm Tack Weld. for all others seal weld
- Fabricated from your drawings.
- Modular panels as detailed below. Call the Webforge office for these Drawings in more detail. STD-003, STD-034.

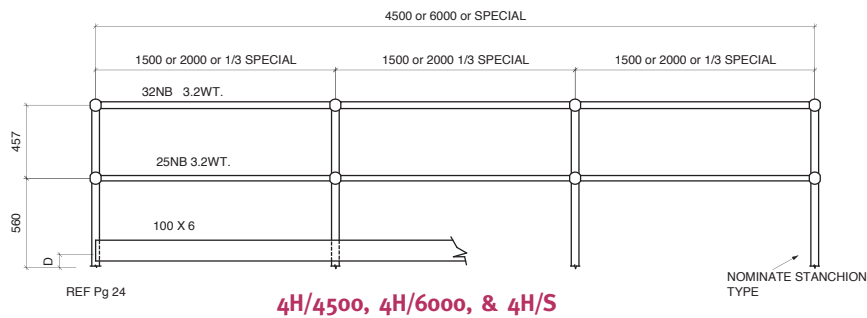
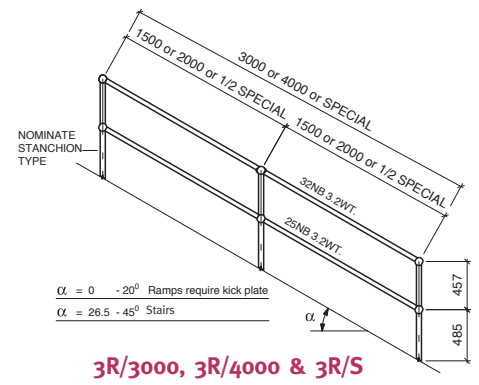
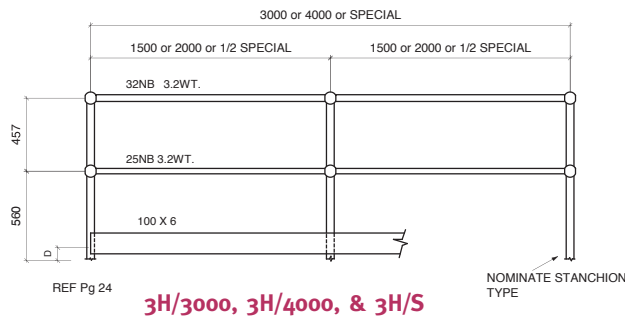
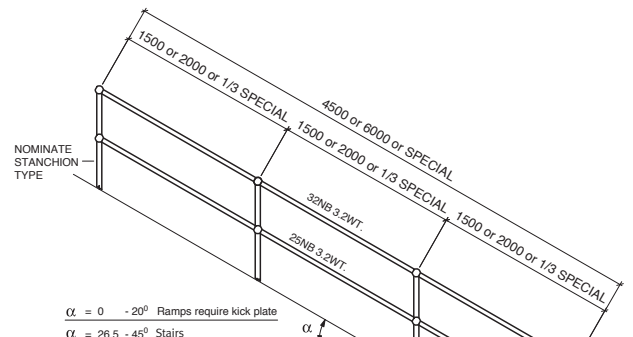
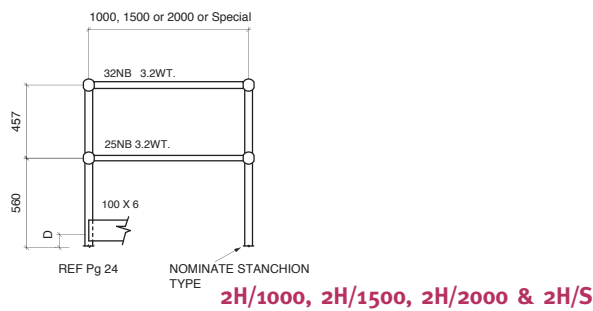

Installation

We can supply and install the complete package on site.

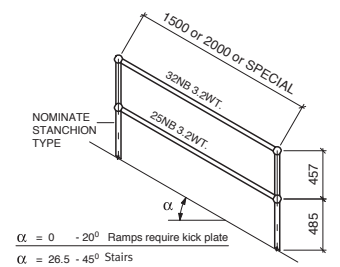

Balustrade



BALUSTRADE

BAL-SP

- Your choice of infill
- Your choice of stanchion type
- Jumbo stanchions

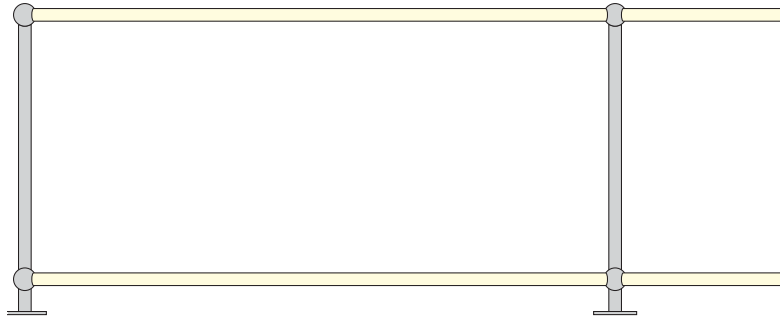

BAL-1

Standard:
32NB top/bottom rails
12mm diameter rods

Jumbo:
65 NB top/bottom rails
16mm diameter rods

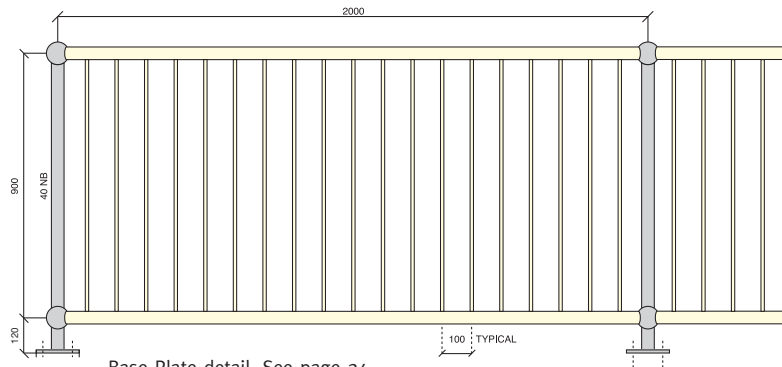

Base Plate detail. See page 24.
Jumbo Base Plate Detail. See Page 30.

BAL-1D

Disable barrier.
As for BAL-1, with the addition of extra railing to comply with requirements of AS1428.1 for disability access.
Additional rail may be applied to other balustrade types by suffix "D".

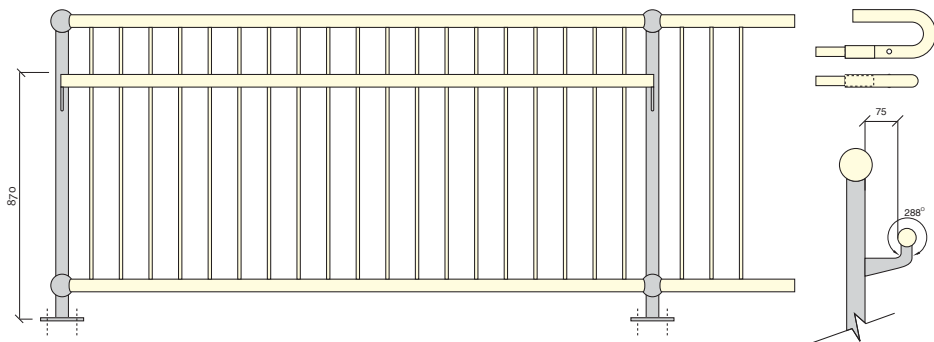



WEBFORGE

Through its network of operations throughout Australia, New Zealand and Asia, Webforge has the resources and experience to service a complete range of projects whatever the complexity or size.

Webforge Worldwide Centres

Australia

Webforge (NSW)
73-75 Bassett Street
Mona Vale NSW 2103
Phone: (02) 9998 1300
Fax: (02) 9998 1340
Postal: PO Box 440
Mona Vale NSW 1660
Email: nsw_sales@webforge.com.au

Webforge (QLD)
1149 Kingsford Smith Drive
Pinkenba QLD 4008
Phone: (07) 3859 8300
Fax: (07) 3859 8390
Postal: PO Box 1452
Eagle Farm QLD 4009
Email: qld_sales@webforge.com.au

Webforge (VIC)
142-146 Fairbank Rd
Clayton South VIC 3169
Phone: (03) 8551 2414
Fax: (03) 8551 2409
Postal: Private Bag 155
Clayton South VIC 3169
Email: vic_sales@webforge.com.au

Webforge (WA)
24 Tennant Street
Welshpool WA 6106
Phone: (08) 9373 5100
Fax: (08) 9373 5108
Postal: PO Box 151
Bentley WA 6982
Email: wa_sales@webforge.com.au

Webforge (North Queensland)
68 Crocodile Crescent
Mount St John QLD 4818
Phone: (07) 4753 1666
Fax: (07) 4753-1650
Postal: PO Box 7740
Garbutt QLD 4814
Email: tville_sales@webforge.com.au

Webforge (Minto)
57-65 Airds Road
Minto NSW 2566
Phone: (02) 9998 1353
Fax: (02) 9998 1351
Postal: PO Box 5262
Minto NSW 2566
Email: minto_sales@webforge.com.au

Webforge (South Australia)
7 Senna Road
Wingfield SA 5013
Phone: (08) 8169 2350
Fax: (08) 08 8169 2355
Postal: PO Box 2607
Regency Park DC SA 5942
Email: sa_sales@webforge.com.au

New Zealand

Webforge (NZ) Ltd
23 Kelvin Grove Road
Palmerston North NZ
Phone: (06) 356 1246
Fax: (06) 356 7782
Postal: PO Box 1506
Palmerston North NZ
Email: nz_sales@webforge.co.nz

Asian Centres

China

Guangzhou Webforge Grating Co Ltd
No. 6 Jinhua 3rd Street
Economic & Technological
Development Zone
Guangzhou 510730
China
Phone: 86 20 8221 2739
Fax: 86 20 8221 2792
Email: gmgeo@gdnet.com.cn

Wuxi Webforge Grating Co.
No. 5 Taishan Road
National Hi-Tech Development Zone
Wuxi, Jiangsu 214028
China
Phone: 0510 8521 1188 126
Fax: 0510 8521 5188
Email: webwuxi@public1.wx.js.cn

Indonesia

PT. Webforge Indonesia
Kawasan Industri Jababeka
Jl. Jababeka V Kav. V-9
Cikarang - Bekasi 17530 Alam
P.O. Box B05/BKSLC/17550A
Indonesia
Phone: 62 21 893 4513
Fax: 62 21 893 4516
E-mail: sales@webforge.co.id

Malaysia

Webforge (KL) Sdn Bhd
Lot 3, Jalan Gudang 16/9
Section 16, 40700 Shah
P.O. Box 7601, 40720 Shah Alam
Selangor Darul Ehsan
Malaysia
Phone: 60 3 5519 0652
Fax: 60 3 5519 0749
Email: webkl@webforge.com.my

Middle East

Webforge Middle East
P.O. Box 18641
LOB 14 544
Jebel Ali Free Zone
Dubai, U.A.E
Phone: 9714 887 3346
Fax: 9714 887 3347
Email: webforge@emirates.net.ae

Phillippines

Webforge Phillipines, Inc.
Main Avenue cor. Hologram Street
Light Industry and Science Park 1
(L.I.S.P.1)
Cabuyao, Laguna 4025
Phillippines
Phone: 63 49 543 0441
Fax: 63 49 543 0440
Email: sales@webforge.com.ph

Singapore

Webforge (Singapore) Pte Ltd
31 Jurong Port Road #02-12M
Jurong Logistic Hub
Singapore 619115
Phone: 65 6861 3611
Fax: 65 6861 8344
Email: sales@webforge.com.sg

Thailand

Webforge (Thailand) Ltd
(Head Office & Factory)
Amata City Industrial Estate
7/110 Moo 4
Tumbol Mapyangporn
Amphur Pluakdaeng
Rayong 21140
Thailand
Phone: 66 38 956 099
Fax: 66 38 956 097
Email: sales@webforge.co.th

(Sales & Marketing)
899 Thai CC Tower
Room #161, 16th Floor
South Sathorn Road, Yannawa
Sathorn, Bangkok 10120
Thailand
Phone: 66 2 672 3972
Fax: 66 2 672 3966

Vietnam

Representative Office in Vietnam
Webforge (KL) Sdn Bhd
Unit 614, Me Linh Point Tower
2 Ngo Duc Ke, District 1
Ho Chi Minh City
Vietnam
Phone: 84 8 520 2787
Fax: 84 8 827 4661
Email: webforgekl_khanh@hcm.vnn.vn

www.webforge.com.au

WEBFORGE

Brochures also available

Architectural Screens
Civil Products
Expanded Metal Products
Planking Products
Outlook Sunscreens

Disclaimer: While Webforge has taken all reasonable care in preparing this brochure, Webforge takes no responsibility for loss resulting from relying on its contents. Customers should make their own enquiries as to whether any products described in this brochure are suitable for their intended use. Information in this brochure may change without notice.